

Appendix B – Hydraulic Calculations

- Normal Depth Calculations – Proposed Conditions Street Sections
- Normal Depth Calculations – Onsite Sections
- Trench Drain Calculations
- HEC-RAS Proposed Conditions Analysis (SiriusAve.prj) (On Data CD)
 - Proposed Conditions Report
 - Summary Tables
 - Reach Profile
 - Cross Sections
 - Lateral Weir Summary Tables
- Finished Floor Elevation Table

Worksheet for MA-2A Meade 100-Yr

Project Description	
Friction Method	Manning Formula
Solve For	Normal Depth

Input Data	
Channel Slope	0.30 %
Discharge	230.50 cfs

Section Definitions

	Station (ft)	Elevation (ft)
	0+00.00	0.60
	0+05.00	0.50
	0+05.50	0.48
	0+05.50	0.00
	0+07.00	0.13
	0+07.00	0.17
	0+30.00	0.60
	0+53.00	0.31
	0+53.00	0.27
	0+54.50	0.14
	0+54.50	0.62
	0+55.00	0.64
	0+60.00	0.74

Roughness Segment Definitions

Start Station	Ending Station	Roughness Coefficient
(0+00.00, 0.60)	(0+60.00, 0.74)	0.016

Options	
Current Roughness Weighted Method	Pavlovskii's Method
Open Channel Weighting Method	Pavlovskii's Method
Closed Channel Weighting Method	Pavlovskii's Method

Results	
Normal Depth	1.30 ft
Roughness Coefficient	0.016
Elevation	1.30 ft
Elevation Range	0.00 to 0.74 ft
Flow Area	51.5 ft ²
Wetted Perimeter	62.32 ft
Hydraulic Radius	0.83 ft
Top Width	60.00 ft

Worksheet for MA-2A Meade 100-Yr

Results

Normal Depth	1.30 ft
Critical Depth	1.21 ft
Critical Slope	0.43 %
Velocity	4.48 ft/s
Velocity Head	0.31 ft
Specific Energy	1.61 ft
Froude Number	0.852
Flow Type	Subcritical

GVF Input Data

Downstream Depth	0.00 ft
Length	0.00 ft
Number Of Steps	0

GVF Output Data

Upstream Depth	0.00 ft
Profile Description	N/A
Profile Headloss	0.00 ft
Downstream Velocity	Infinity ft/s
Upstream Velocity	Infinity ft/s
Normal Depth	1.30 ft
Critical Depth	1.21 ft
Channel Slope	0.30 %
Critical Slope	0.43 %

Cross Section for MA-2A Meade 100-Yr

Project Description	
Friction Method	Manning Formula
Solve For	Normal Depth

Input Data	
Channel Slope	0.30 %
Normal Depth	1.30 ft
Discharge	230.50 cfs

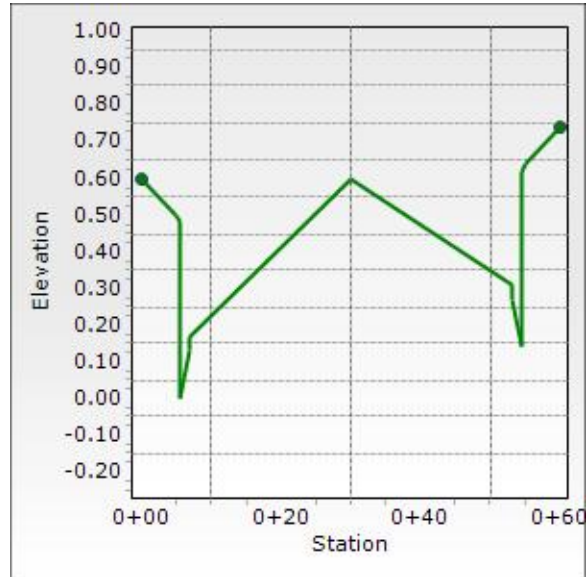

Worksheet for MA-2B Meade 100-Yr

Project Description	
Friction Method	Manning Formula
Solve For	Normal Depth

Input Data	
Channel Slope	0.51 %
Discharge	228.50 cfs

Section Definitions

Station (ft)		Elevation (ft)
	0+00.00	0.60
	0+05.00	0.50
	0+05.50	0.48
	0+05.50	0.00
	0+07.00	0.13
	0+07.00	0.17
	0+30.00	0.63
	0+53.00	0.17
	0+53.00	0.13
	0+54.50	0.00
	0+54.50	0.48
	0+55.00	0.50
	0+55.00	0.50
	0+65.00	0.70
	0+65.00	1.10

Roughness Segment Definitions

Start Station	Ending Station	Roughness Coefficient
(0+00.00, 0.60)	(0+65.00, 1.10)	0.016

Options

Current Roughness Weighted Method	Pavlovskii's Method
Open Channel Weighting Method	Pavlovskii's Method
Closed Channel Weighting Method	Pavlovskii's Method

Results

Normal Depth	1.12 ft
Roughness Coefficient	0.016
Elevation	1.12 ft
Elevation Range	0.00 to 1.10 ft
Flow Area	45.0 ft ²
Wetted Perimeter	67.00 ft

Worksheet for MA-2B Meade 100-Yr

Results

Hydraulic Radius	0.67 ft
Top Width	65.00 ft
Normal Depth	1.12 ft
Critical Depth	1.16 ft
Critical Slope	0.43 %
Velocity	5.08 ft/s
Velocity Head	0.40 ft
Specific Energy	1.52 ft
Froude Number	1.078
Flow Type	Supercritical

GVF Input Data

Downstream Depth	0.00 ft
Length	0.00 ft
Number Of Steps	0

GVF Output Data

Upstream Depth	0.00 ft
Profile Description	N/A
Profile Headloss	0.00 ft
Downstream Velocity	Infinity ft/s
Upstream Velocity	Infinity ft/s
Normal Depth	1.12 ft
Critical Depth	1.16 ft
Channel Slope	0.51 %
Critical Slope	0.43 %

Cross Section for MA-2B Meade 100-Yr

Project Description	
Friction Method	Manning Formula
Solve For	Normal Depth

Input Data	
Channel Slope	0.51 %
Normal Depth	1.12 ft
Discharge	228.50 cfs

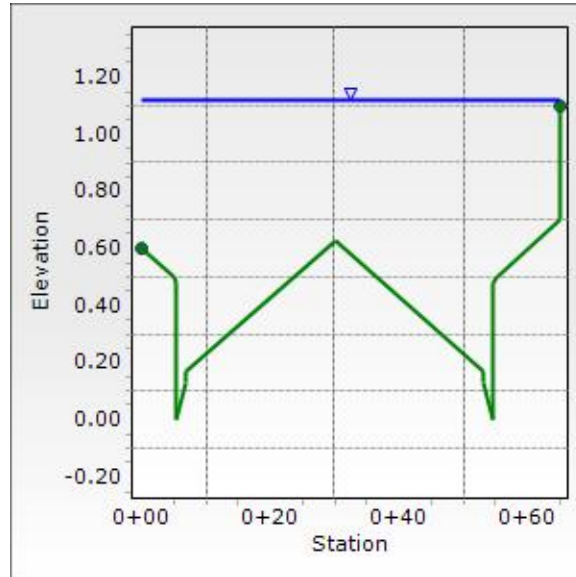

Worksheet for MA-2C Meade 100-Yr

Project Description	
Friction Method	Manning Formula
Solve For	Normal Depth

Input Data	
Channel Slope	1.40 %
Discharge	226.00 cfs

Section Definitions

	Station (ft)	Elevation (ft)
	0+00.00	0.75
	0+05.00	0.65
	0+05.50	0.63
	0+05.50	0.15
	0+07.00	0.28
	0+07.00	0.32
	0+30.00	0.45
	0+53.00	0.17
	0+53.00	0.13
	0+54.50	0.00
	0+54.50	0.48
	0+55.00	0.50
	0+60.00	0.60

Roughness Segment Definitions

Start Station	Ending Station	Roughness Coefficient
(0+00.00, 0.75)	(0+60.00, 0.60)	0.016

Options

Current Roughness Weighted Method	Pavlovskii's Method
Open Channel Weighting Method	Pavlovskii's Method
Closed Channel Weighting Method	Pavlovskii's Method

Results

Normal Depth	0.92 ft
Roughness Coefficient	0.016
Elevation	0.92 ft
Elevation Range	0.00 to 0.75 ft
Flow Area	31.9 ft ²
Wetted Perimeter	61.54 ft
Hydraulic Radius	0.52 ft
Top Width	60.00 ft

Worksheet for MA-2C Meade 100-Yr

Results

Normal Depth	0.92 ft
Critical Depth	1.15 ft
Critical Slope	0.43 %
Velocity	7.09 ft/s
Velocity Head	0.78 ft
Specific Energy	1.70 ft
Froude Number	1.715
Flow Type	Supercritical

GVF Input Data

Downstream Depth	0.00 ft
Length	0.00 ft
Number Of Steps	0

GVF Output Data

Upstream Depth	0.00 ft
Profile Description	N/A
Profile Headloss	0.00 ft
Downstream Velocity	Infinity ft/s
Upstream Velocity	Infinity ft/s
Normal Depth	0.92 ft
Critical Depth	1.15 ft
Channel Slope	1.40 %
Critical Slope	0.43 %

Cross Section for MA-2C Meade 100-Yr

Project Description	
Friction Method	Manning Formula
Solve For	Normal Depth

Input Data	
Channel Slope	1.40 %
Normal Depth	0.92 ft
Discharge	226.00 cfs

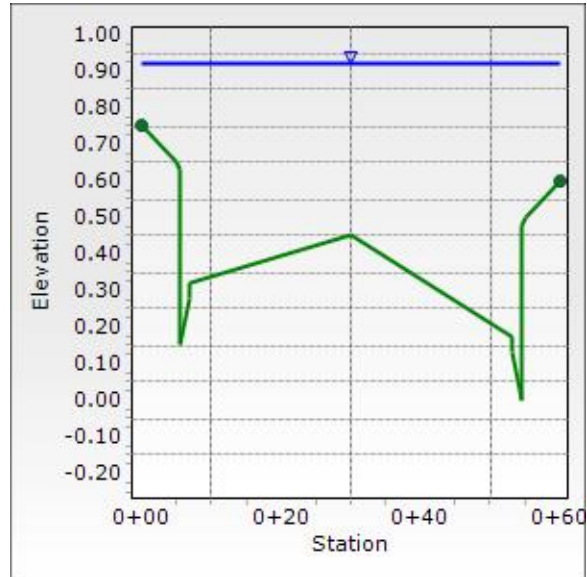

Worksheet for RA-1 - Rigel 100-Yr

Project Description	
Friction Method	Manning Formula
Solve For	Normal Depth

Input Data	
Channel Slope	0.68 %
Discharge	138.50 cfs

Section Definitions

	Station (ft)	Elevation (ft)
	0+00.00	2.90
	0+05.00	2.80
	0+05.50	2.78
	0+05.50	2.30
	0+07.00	2.43
	0+07.00	2.47
	0+53.00	0.17
	0+53.00	0.13
	0+54.50	0.00
	0+54.50	0.48
	0+55.00	0.50
	0+55.00	0.50
	0+60.00	0.60
	0+60.00	3.60

Roughness Segment Definitions

Start Station	Ending Station	Roughness Coefficient
(0+00.00, 2.90)	(0+60.00, 3.60)	0.016

Options

Current Roughness Weighted Method	Pavlovskii's Method
Open Channel Weighting Method	Pavlovskii's Method
Closed Channel Weighting Method	Pavlovskii's Method

Results

Normal Depth	1.44 ft
Roughness Coefficient	0.016
Elevation	1.44 ft
Elevation Range	0.00 to 3.60 ft
Flow Area	23.2 ft ²
Wetted Perimeter	33.88 ft
Hydraulic Radius	0.69 ft

Worksheet for RA-1 - Rigel 100-Yr

Results

Top Width	32.48 ft
Normal Depth	1.44 ft
Critical Depth	1.57 ft
Critical Slope	0.43 %
Velocity	5.96 ft/s
Velocity Head	0.55 ft
Specific Energy	2.00 ft
Froude Number	1.242
Flow Type	Supercritical

GVF Input Data

Downstream Depth	0.00 ft
Length	0.00 ft
Number Of Steps	0

GVF Output Data

Upstream Depth	0.00 ft
Profile Description	N/A
Profile Headloss	0.00 ft
Downstream Velocity	Infinity ft/s
Upstream Velocity	Infinity ft/s
Normal Depth	1.44 ft
Critical Depth	1.57 ft
Channel Slope	0.68 %
Critical Slope	0.43 %

Cross Section for RA-1 - Rigel 100-Yr

Project Description	
Friction Method	Manning Formula
Solve For	Normal Depth

Input Data	
Channel Slope	0.68 %
Normal Depth	1.44 ft
Discharge	138.50 cfs

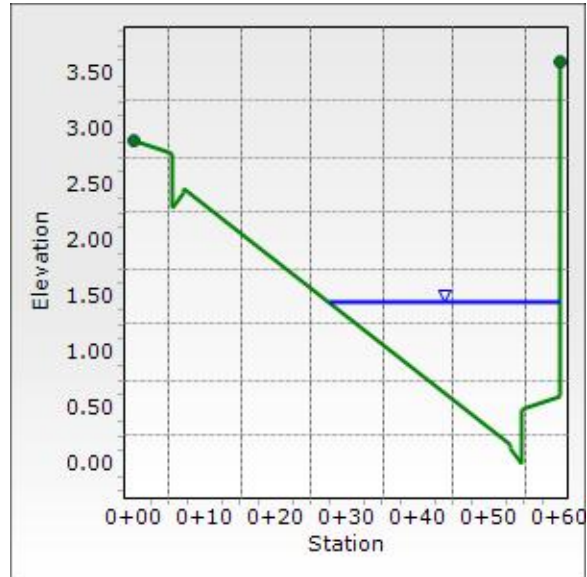

Worksheet for RA-2 - Rigel 100-Yr

Project Description	
Friction Method	Manning Formula
Solve For	Normal Depth

Input Data	
Channel Slope	0.60 %
Discharge	141.00 cfs

Section Definitions

	Station (ft)	Elevation (ft)
	0+00.00	5.91
	0+00.00	2.91
	0+05.00	2.81
	0+05.50	2.79
	0+05.50	2.31
	0+07.00	2.44
	0+07.00	2.47
	0+53.00	0.17
	0+53.00	0.13
	0+54.50	0.00
	0+54.50	0.48
	0+55.00	0.50
	0+55.00	0.50
	0+60.00	0.60
	0+60.00	3.60

Roughness Segment Definitions

Start Station	Ending Station	Roughness Coefficient
(0+00.00, 5.91)	(0+60.00, 3.60)	0.016

Options

Current Roughness Weighted Method	Pavlovskii's Method
Open Channel Weighting Method	Pavlovskii's Method
Closed Channel Weighting Method	Pavlovskii's Method

Results

Normal Depth	1.49 ft
Roughness Coefficient	0.016
Elevation	1.49 ft
Elevation Range	0.00 to 5.91 ft
Flow Area	24.7 ft ²
Wetted Perimeter	34.78 ft

Worksheet for RA-2 - Rigel 100-Yr

Results

Hydraulic Radius	0.71 ft
Top Width	33.34 ft
Normal Depth	1.49 ft
Critical Depth	1.58 ft
Critical Slope	0.43 %
Velocity	5.72 ft/s
Velocity Head	0.51 ft
Specific Energy	2.00 ft
Froude Number	1.172
Flow Type	Supercritical

GVF Input Data

Downstream Depth	0.00 ft
Length	0.00 ft
Number Of Steps	0

GVF Output Data

Upstream Depth	0.00 ft
Profile Description	N/A
Profile Headloss	0.00 ft
Downstream Velocity	Infinity ft/s
Upstream Velocity	Infinity ft/s
Normal Depth	1.49 ft
Critical Depth	1.58 ft
Channel Slope	0.60 %
Critical Slope	0.43 %

Cross Section for RA-2 - Rigel 100-Yr

Project Description	
Friction Method	Manning Formula
Solve For	Normal Depth
Input Data	
Channel Slope	0.60 %
Normal Depth	1.49 ft
Discharge	141.00 cfs

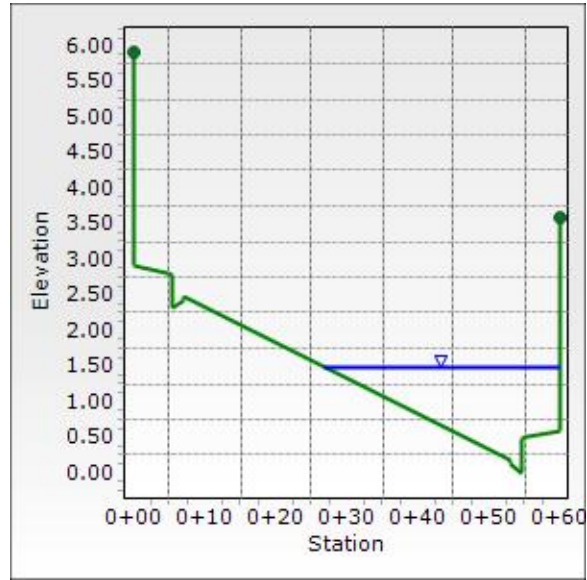

Worksheet for RA - Rigel 100-Yr

Project Description	
Friction Method	Manning Formula
Solve For	Normal Depth

Input Data	
Channel Slope	0.45 %
Discharge	135.50 cfs

Section Definitions

	Station (ft)	Elevation (ft)	
	0+00.00		0.60
	0+05.00		0.50
	0+05.00		0.50
	0+05.50		0.48
	0+05.50		0.00
	0+07.00		0.13
	0+07.00		0.17
	0+30.00		0.63
	0+30.00		0.63
	0+53.00		0.17
	0+53.00		0.13
	0+54.50		0.00
	0+54.50		0.48
	0+55.00		0.50
	0+55.00		0.50
	0+55.00		0.50
	0+60.00		0.60
	0+60.00		3.60

Roughness Segment Definitions

Start Station	Ending Station	Roughness Coefficient
(0+00.00, 0.60)	(0+60.00, 3.60)	0.016

Options

Current Roughness Weighted Method	Pavlovskii's Method
Open Channel Weighting Method	Pavlovskii's Method
Closed Channel Weighting Method	Pavlovskii's Method

Results

Normal Depth	0.96 ft
Roughness Coefficient	0.016
Elevation	0.96 ft

Worksheet for RA - Rigel 100-Yr

Results

Elevation Range	0.00 to 3.60 ft
Flow Area	33.0 ft ²
Wetted Perimeter	61.78 ft
Hydraulic Radius	0.53 ft
Top Width	60.00 ft
Normal Depth	0.96 ft
Critical Depth	0.95 ft
Critical Slope	0.48 %
Velocity	4.10 ft/s
Velocity Head	0.26 ft
Specific Energy	1.22 ft
Froude Number	0.975
Flow Type	Subcritical

GVF Input Data

Downstream Depth	0.00 ft
Length	0.00 ft
Number Of Steps	0

GVF Output Data

Upstream Depth	0.00 ft
Profile Description	N/A
Profile Headloss	0.00 ft
Downstream Velocity	Infinity ft/s
Upstream Velocity	Infinity ft/s
Normal Depth	0.96 ft
Critical Depth	0.95 ft
Channel Slope	0.45 %
Critical Slope	0.48 %

Cross Section for RA - Rigel 100-Yr

Project Description	
Friction Method	Manning Formula
Solve For	Normal Depth
Input Data	
Channel Slope	0.45 %
Normal Depth	0.96 ft
Discharge	135.50 cfs

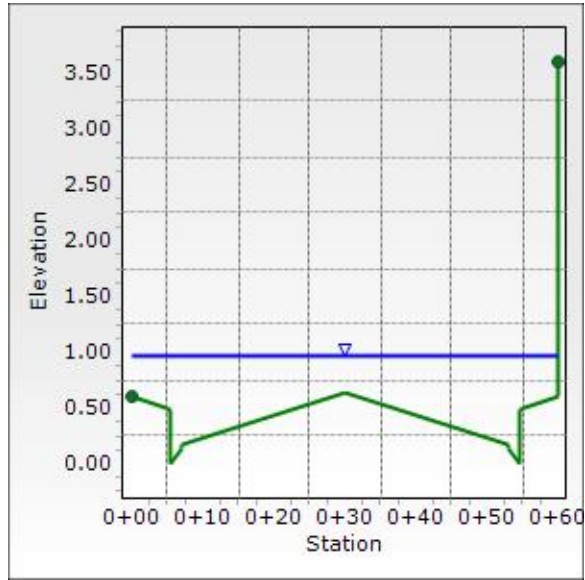

Worksheet for ONP2 South

Project Description

Friction Method	Manning Formula
Solve For	Normal Depth

Input Data

Channel Slope	1.12 %
Discharge	1.50 cfs

Section Definitions

	Station (ft)	Elevation (ft)	
	0+00.00		0.20
	0+11.50		0.00
	0+11.50		4.00

Roughness Segment Definitions

Start Station	Ending Station	Roughness Coefficient	
(0+00.00, 0.20)	(0+11.50, 4.00)	0.016	

Options

Current Roughness Weighted Method	Pavlovskii's Method
Open Channel Weighting Method	Pavlovskii's Method
Closed Channel Weighting Method	Pavlovskii's Method

Results

Normal Depth	0.17 ft
Roughness Coefficient	0.016
Elevation	0.17 ft
Elevation Range	0.00 to 4.00 ft
Flow Area	0.8 ft ²
Wetted Perimeter	9.80 ft
Hydraulic Radius	0.08 ft
Top Width	9.63 ft
Normal Depth	0.17 ft
Critical Depth	0.18 ft
Critical Slope	0.86 %
Velocity	1.86 ft/s
Velocity Head	0.05 ft
Specific Energy	0.22 ft
Froude Number	1.132
Flow Type	Supercritical

GVF Input Data

Worksheet for ONP2 South

GVF Input Data

Downstream Depth	0.00 ft
Length	0.00 ft
Number Of Steps	0

GVF Output Data

Upstream Depth	0.00 ft
Profile Description	N/A
Profile Headloss	0.00 ft
Downstream Velocity	Infinity ft/s
Upstream Velocity	Infinity ft/s
Normal Depth	0.17 ft
Critical Depth	0.18 ft
Channel Slope	1.12 %
Critical Slope	0.86 %

Cross Section for ONP2 South

Project Description	
Friction Method	Manning Formula
Solve For	Normal Depth

Input Data	
Channel Slope	1.12 %
Normal Depth	0.17 ft
Discharge	1.50 cfs

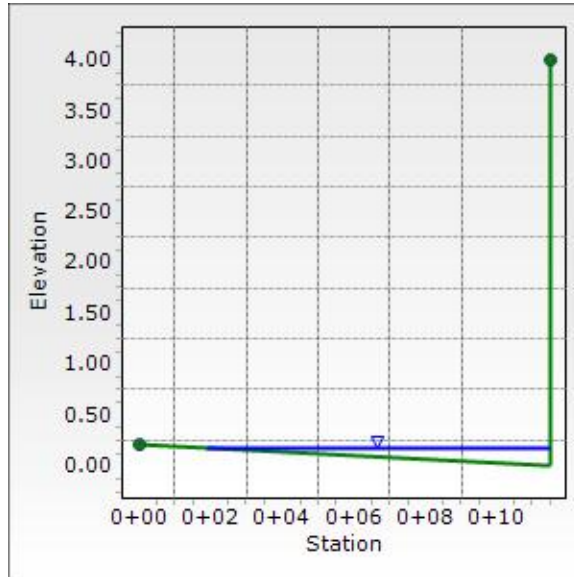

Grate Inlet Headwater Depth Calculation

4.5-in by 75-ft Trench Drain ONV #1

Known:

Q=	Flow (cfs)	1.0
W=	Width of Grate (ft)	0.375
L=	Length of Grate (ft)	75.0
D=	Diameter of Circle (in)	
Cf=	Clogging Factor (%)	50

Weir Conditions:

$$Hw = (Q / (Cw * P))^{2/3}$$

Cw=	Weir Coefficient	2.7
P=	Perimeter of grate (ft)	150.8
Pc=	Perimeter (w/clogging) (ft)	75.4
Hw=	Headwater depth (ft)	0.03

Orifice Conditions:

$$Hw = (Q / (Co * Ac))^2 / 2 * g$$

Co=	Orifice Coefficient	0.67
Ag=	Grate Area (ft ²)	28.1
Gf=	Grate Opening Factor	0.25
Ac=	Grate Open Area (w/ clogging) (ft ²)	3.5
Hw=	Headwater depth (ft)	0.00

Worst Case Scenario Occurs Under Weir Conditions

Headwater Depth (ft) = 0.03

Grate Inlet Headwater Depth Calculation

4.5-in by 63-ft Trench Drain ONV #2

Known:

Q= Flow (cfs)	1.0
W= Width of Grate (ft)	0.375
L= Length of Grate (ft)	63.0
D= Diameter of Circle (in)	
Cf= Clogging Factor (%)	50

Weir Conditions:

$$Hw = (Q / (Cw * P))^{2/3}$$

Cw= Weir Coefficient	2.7
P= Perimeter of grate (ft)	126.8
Pc= Perimeter (w/clogging) (ft)	63.4
Hw= Headwater depth (ft)	0.03

Orifice Conditions:

$$Hw = (Q / (Co * Ac))^2 / 2 * g$$

Co= Orifice Coefficient	0.67
Ag= Grate Area (ft ²)	23.6
Gf= Grate Opening Factor	0.25
Ac= Grate Open Area (w/ clogging) (ft ²)	3.0
Hw= Headwater depth (ft)	0.00

Worst Case Scenario Occurs Under Weir Conditions

Headwater Depth (ft) = 0.03

HEC-RAS HEC-RAS 5.0.7 March 2019
 U. S. Army Corps of Engineers
 Hydrologic Engineering Center
 609 Second Street
 Davis, California

```

X   X   XXXXXX   XXXX   XXXX   XX   XXXX
X   X   X       X   X   X   X   X   X   X
X   X   X       X       X   X   X   X   X
XXXXXXXX XXXX   X       XXX XXXX   XXXXXX   XXXX
X   X   X       X       X   X   X   X   X
X   X   X       X   X   X   X   X   X   X
X   X   XXXXXX   XXXX   X   X   X   X   XXXXX
    
```

PROJECT DATA

Project Title: Sirius Avenue
 Project File : SiriusAvenue.prj
 Run Date and Time: 1/31/2025 11:20:01 AM

Project in English units

PLAN DATA

Plan Title: Proposed Conditions_District2_UP3_2025
 Plan File : k:\LAV_Civil\092965012 - Area 15 District 2 (Fisher Brothers)\Reports\DRAINAGE\07_UP3\Calculations\Hydraulics\HECRAS\SiriusAvenue.p08

Geometry Title: Proposed Conditions_Geom_District2_UP3
 Geometry File : k:\LAV_Civil\092965012 - Area 15 District 2 (Fisher Brothers)\Reports\DRAINAGE\07_UP3\Calculations\Hydraulics\HECRAS\SiriusAvenue.g04

Flow Title : Sirius_EventLots
 Flow File : k:\LAV_Civil\092965012 - Area 15 District 2 (Fisher Brothers)\Reports\DRAINAGE\07_UP3\Calculations\Hydraulics\HECRAS\SiriusAvenue.f02

Plan Summary Information:

Number of: Cross Sections = 7 Multiple Openings = 0
 Culverts = 0 Inline Structures = 0
 Bridges = 0 Lateral Structures = 2

Computational Information

Water surface calculation tolerance = 0.01
 Critical depth calculation tolerance = 0.01
 Maximum number of iterations = 20
 Maximum difference tolerance = 0.3
 Flow tolerance factor = 0.001

Computation Options

Critical depth computed at all cross sections
 Conveyance Calculation Method: At breaks in n values only
 Friction Slope Method: Program Selects Appropriate method
 Computational Flow Regime: Supercritical Flow

FLOW DATA

Flow Title: Sirius_EventLots
 Flow File : k:\LAV_Civil\092965012 - Area 15 District 2 (Fisher Brothers)\Reports\DRAINAGE\07_UP3\Calculations\Hydraulics\HECRAS\SiriusAvenue.f02

Flow Data (cfs)

River	Reach	RS	100-yr
SIRIUS AVE	SIRIUS	1916	1158
SIRIUS AVE	SIRIUS	1215	1158
SIRIUS AVE	SIRIUS	1036	1158

Boundary Conditions

River	Reach	Profile	Upstream	Downstream
SIRIUS AVE	SIRIUS	100-yr	Critical	Critical

GEOMETRY DATA

Geometry Title: Proposed Conditions_Geom_District2_UP3
 Geometry File : k:\LAV_Civil\092965012 - Area 15 District 2 (Fisher Brothers)\Reports\DRAINAGE\07_UP3\Calculations\Hydraulics\HECRAS\SiriusAvenue.g04

CROSS SECTION

RIVER: SIRIUS AVE
 REACH: SIRIUS RS: 1916

INPUT

Description:

Station		Elevation		Data		num=		42	
Sta	Elev	Sta	Elev	Sta	Elev	Sta	Elev	Sta	Elev
0	2124	45.66	2124	47.74	2123.09	50.09	2122	52.26	2121.54
58.04	2121.25	58.1	2120.75	59.6	2120.86	82.6	2121	105.6	2120.81
107.1	2120.7	107.1	2121.2	112.1	2121.2	115.24	2121.48	115.44	2121.47
116.39	2121.5	117.08	2121.52	124.01	2121.77	127.89	2121.9	128.11	2121.92
128.26	2121.93	216.93	2122	219.4	2121.94	219.67	2121.94	226.29	2121.76
229.79	2121.74	234.52	2121.87	234.72	2121.86	236.6	2121.87	236.67	2121.87
240.82	2122	339.66	2122.04	339.8	2122.02	339.82	2122.02	343.87	2122.35
344.04	2122.35	348.23	2122.68	350.49	2122.83	357.66	2122.9	363.61	2123.1
364.9	2123.14	365.91	2123.19						

Manning's n		Values		num=		6			
Sta	n Val	Sta	n Val	Sta	n Val	Sta	n Val		
0	.016	58.04	.013	59.6	.016	105.6	.013	112.1	.025
339.82	.016								

Bank Sta:	Left	Right	Lengths:	Left Channel	Right	Coeff	Contr.	Expan.
	50.09	128.11		166.86	166.86		.1	.3

CROSS SECTION

RIVER: SIRIUS AVE
 REACH: SIRIUS RS: 1750

INPUT

Description:

Station		Elevation		Data		num=		14	
Sta	Elev	Sta	Elev	Sta	Elev	Sta	Elev	Sta	Elev
0	2120.4	0	2118	53	2117	53	2116.5	54.5	2116.61
77.5	2117.2	90.5	2116.66	92	2116.55	92	2117.05	97	2117.58
97	2120	97.5	2120	97.5	2117.58	100.5	2117.6		

Manning's n		Values		num=		5			
Sta	n Val	Sta	n Val	Sta	n Val	Sta	n Val		
0	.016	53	.013	54.5	.016	90.5	.013	97.5	.02

Bank Sta:	Left	Right	Lengths:	Left Channel	Right	Coeff	Contr.	Expan.
	53	92		216.84	216.84		.1	.3
Right Levee		Station=	97	Elevation=	2120			

CROSS SECTION

RIVER: SIRIUS AVE
 REACH: SIRIUS RS: 1533

INPUT

Description:

Station		Elevation		Data		num=		19	
Sta	Elev	Sta	Elev	Sta	Elev	Sta	Elev	Sta	Elev
0	2114.3	0	2112	17	2111.7	34	2112	59	2113.2
59	2116	59	2120.5	59.5	2120.5	59.5	2116	59.5	2113.2
65.5	2112.5	65.5	2112	67	2112.11	90	2112.67	113	2112.11
118	2112.58	118	2113.08	124	2113	150	2114		

Manning's n		Values		num=		7			
Sta	n Val	Sta	n Val	Sta	n Val	Sta	n Val		
0	.016	59	.02	59.5	.016	65.5	.013	67	.016
113	.013	124	.02						

Bank Sta:	Left	Right	Lengths:	Left Channel	Right	Coeff	Contr.	Expan.
	65.5	118		318.07	318.07		.1	.3
Ineffective Flow		num=	1					
Sta L	Sta R	Elev	Permanent					
124	150	2115.42	F					
Left Levee	Station=	59.5	Elevation=	2116				

LATERAL STRUCTURE

RIVER: SIRIUS AVE
 REACH: SIRIUS RS: 1245

INPUT

Description:

Lateral structure position = Left overbank
 Distance from Upstream XS =
 Deck/Roadway Width = 10
 Weir Coefficient = 3
 Weir Flow Reference = Water Surface
 Weir Embankment Coordinates num = 3

Sta	Elev	Sta	Elev	Sta	Elev
0	2109.8	30	2110.3	60	2109.9

Weir crest shape = Broad Crested

CROSS SECTION

RIVER: SIRIUS AVE
 REACH: SIRIUS RS: 1215

INPUT

Description:

Station Elevation Data		num= 11	
Sta	Elev	Sta	Elev
0	2110.3	93	2110
150	2110	173	2109.8
191.5	2114.45		

Manning's n Values		num= 5	
Sta	n Val	Sta	n Val
0	.016	119	.013
		127	.016
		173	.013
		191.5	.015

Bank Sta:	Left	Right	Lengths:	Left Channel	Right	Coeff	Contr.	Expan.
	119	174.5		45	45		.1	.3
Right Levee	Station=		191.5	Elevation=	2114.45			

LATERAL STRUCTURE

RIVER: SIRIUS AVE
 REACH: SIRIUS RS: 1177

INPUT

Description:

Lateral structure position = Left overbank

Distance from Upstream XS =

Deck/Roadway Width = 1

Weir Coefficient = 3

Weir Flow Reference = Water Surface

Weir Embankment Coordinates num = 2

Sta	Elev	Sta	Elev
0	2111.09	14	2111.1

Weir crest shape = Broad Crested

CROSS SECTION

RIVER: SIRIUS AVE
 REACH: SIRIUS RS: 1170

INPUT

Description:

Station Elevation Data		num= 15	
Sta	Elev	Sta	Elev
139.4	2111.1	142.47	2110.98
200.12	2109.4	200.12	2108.9
252.35	2108.93	252.35	2109.43
		269.35	2109.77
		269.35	2113.77
		270.49	2113.77

Manning's n Values		num= 2	
Sta	n Val	Sta	n Val
139.4	.016	269.35	.013

Bank Sta:	Left	Right	Lengths:	Left Channel	Right	Coeff	Contr.	Expan.
	200.12	252.35		10	10		.1	.3
Right Levee	Station=		269.35	Elevation=	2113.77			

CROSS SECTION

RIVER: SIRIUS AVE
 REACH: SIRIUS RS: 1160

INPUT

Description:

Station Elevation Data		num= 15	
Sta	Elev	Sta	Elev
221.4	2111.22	222.4	2111.22
232.4	2108	233.9	2108.17
283.9	2108.5	288.9	2108.6
		293.9	2108.7
		293.9	2111.22
		294.9	2111.22

Manning's n Values		num= 3	
Sta	n Val	Sta	n Val
221.4	.013	222.4	.016
		293.9	.013

Bank Sta:	Left	Right	Lengths:	Left Channel	Right	Coeff	Contr.	Expan.
	232.4	283.9		124	124		.1	.3

CROSS SECTION

RIVER: SIRIUS AVE
 REACH: SIRIUS RS: 1036

INPUT

Description:

Station Elevation Data		num= 15		Sta	Elev	Sta	Elev	Sta	Elev	Sta	Elev
Sta	Elev	Sta	Elev	Sta	Elev	Sta	Elev	Sta	Elev	Sta	Elev
221.4	2111.22	222.4	2111.22	222.4	2108.7	227.4	2108.6	232.4	2108.5		
232.4	2108	233.9	2108.17	256.9	2108.3	281.9	2108.17	283.9	2108		
283.9	2108.5	288.9	2108.6	293.9	2108.7	293.9	2111.22	294.9	2111.22		

Manning's n Values		num= 3		Sta	n Val	Sta	n Val	Sta	n Val
221.4	.013	222.4	.016	293.9	.013				

Bank Sta:	Left	Right	Lengths:	Left Channel	Right	Coeff	Contr.	Expan.
232.4	283.9			0	0		.1	.3

SUMMARY OF MANNING'S N VALUES

River: SIRIUS AVE

Reach	River Sta.	n1	n2	n3	n4	n5	n6	n7
SIRIUS	1916	.016	.013	.016	.013	.025	.016	
SIRIUS	1750	.016	.013	.016	.013	.02		
SIRIUS	1533	.016	.02	.016	.013	.016	.013	.02
SIRIUS	1245	Lat Struct						
SIRIUS	1215	.016	.013	.016	.013	.015		
SIRIUS	1177	Lat Struct						
SIRIUS	1170	.016	.013					
SIRIUS	1160	.013	.016	.013				
SIRIUS	1036	.013	.016	.013				

SUMMARY OF REACH LENGTHS

River: SIRIUS AVE

Reach	River Sta.	Left	Channel	Right
SIRIUS	1916	166.86	166.86	166.86
SIRIUS	1750	216.84	216.84	216.84
SIRIUS	1533	318.07	318.07	318.07
SIRIUS	1245	Lat Struct		
SIRIUS	1215	45	45	45
SIRIUS	1177	Lat Struct		
SIRIUS	1170	10	10	10
SIRIUS	1160	124	124	124
SIRIUS	1036	0	0	0

SUMMARY OF CONTRACTION AND EXPANSION COEFFICIENTS

River: SIRIUS AVE

Reach	River Sta.	Contr.	Expan.
SIRIUS	1916	.1	.3
SIRIUS	1750	.1	.3
SIRIUS	1533	.1	.3
SIRIUS	1245	Lat Struct	
SIRIUS	1215	.1	.3
SIRIUS	1177	Lat Struct	
SIRIUS	1170	.1	.3
SIRIUS	1160	.1	.3
SIRIUS	1036	.1	.3

HEC-RAS Plan: UP3 River: SIRIUS AVE Reach: SIRIUS Profile: 100-yr

Reach	River Sta	Profile	Q Total (cfs)	Min Ch El (ft)	W.S. Elev (ft)	Crit W.S. (ft)	E.G. Elev (ft)	E.G. Slope (ft/ft)	Vel Chnl (ft/s)	Flow Area (sq ft)	Top Width (ft)	Froude # Chl
SIRIUS	1916	100-yr	1158.00	2120.70	2122.70	2122.70	2123.12	0.002954	6.11	279.55	300.01	0.86
SIRIUS	1750	100-yr	1158.00	2116.50	2118.17	2118.93	2121.04	0.018848	15.07	89.95	97.00	2.35
SIRIUS	1533	100-yr	1158.00	2112.00	2113.72	2114.66	2117.08	0.017287	15.03	79.58	83.11	2.29
SIRIUS	1245		Lat Struct									
SIRIUS	1215	100-yr	1096.19	2109.25	2110.68	2111.03	2111.88	0.011836	10.26	130.44	191.50	1.89
SIRIUS	1177		Lat Struct									
SIRIUS	1170	100-yr	1046.78	2108.90	2110.95	2110.95	2111.61	0.003065	7.18	166.05	126.18	0.98
SIRIUS	1160	100-yr	1046.78	2108.00	2109.75	2110.23	2111.45	0.008017	10.86	101.32	71.50	1.55
SIRIUS	1036	100-yr	1046.78	2108.00	2110.23	2110.23	2111.17	0.003089	8.10	135.73	71.50	1.01

Plan: UP3 SIRIUS AVE SIRIUS RS: 1916 Profile: 100-yr

E.G. Elev (ft)	2123.12	Element	Left OB	Channel	Right OB
Vel Head (ft)	0.41	Wt. n-Val.	0.016	0.018	0.025
W.S. Elev (ft)	2122.70	Reach Len. (ft)	166.86	166.86	166.86
Crit W.S. (ft)	2122.70	Flow Area (sq ft)	0.53	122.53	156.49
E.G. Slope (ft/ft)	0.002954	Area (sq ft)	0.53	122.53	156.49
Q Total (cfs)	1158.00	Flow (cfs)	1.26	749.16	407.58
Top Width (ft)	300.01	Top Width (ft)	1.52	78.02	220.48
Vel Total (ft/s)	4.14	Avg. Vel. (ft/s)	2.36	6.11	2.60
Max Chl Dpth (ft)	2.00	Hydr. Depth (ft)	0.35	1.57	0.71
Conv. Total (cfs)	21304.9	Conv. (cfs)	23.1	13783.1	7498.6
Length Wtd. (ft)	166.86	Wetted Per. (ft)	1.67	79.05	220.51
Min Ch El (ft)	2120.70	Shear (lb/sq ft)	0.06	0.29	0.13
Alpha	1.55	Stream Power (lb/ft s)	0.14	1.75	0.34
Frctn Loss (ft)	1.82	Cum Volume (acre-ft)	0.57	1.42	0.47
C & E Loss (ft)	0.25	Cum SA (acres)	0.83	1.06	0.71

Plan: UP3 SIRIUS AVE SIRIUS RS: 1750 Profile: 100-yr

E.G. Elev (ft)	2121.04	Element	Left OB	Channel	Right OB
Vel Head (ft)	2.87	Wt. n-Val.	0.016	0.016	0.013
W.S. Elev (ft)	2118.17	Reach Len. (ft)	216.84	216.84	216.84
Crit W.S. (ft)	2118.93	Flow Area (sq ft)	35.61	50.06	4.28
E.G. Slope (ft/ft)	0.018848	Area (sq ft)	35.61	50.06	4.28
Q Total (cfs)	1158.00	Flow (cfs)	347.49	754.40	56.10
Top Width (ft)	97.00	Top Width (ft)	53.00	39.00	5.00
Vel Total (ft/s)	12.87	Avg. Vel. (ft/s)	9.76	15.07	13.10
Max Chl Dpth (ft)	1.67	Hydr. Depth (ft)	0.67	1.28	0.86
Conv. Total (cfs)	8434.7	Conv. (cfs)	2531.1	5495.0	408.6
Length Wtd. (ft)	216.84	Wetted Per. (ft)	53.18	40.03	5.62
Min Ch El (ft)	2116.50	Shear (lb/sq ft)	0.79	1.47	0.90
Alpha	1.12	Stream Power (lb/ft s)	7.69	22.18	11.75
Frctn Loss (ft)	3.91	Cum Volume (acre-ft)	0.50	1.09	0.16
C & E Loss (ft)	0.05	Cum SA (acres)	0.73	0.84	0.27

Plan: UP3 SIRIUS AVE SIRIUS RS: 1533 Profile: 100-yr

E.G. Elev (ft)	2117.08	Element	Left OB	Channel	Right OB
Vel Head (ft)	3.37	Wt. n-Val.	0.016	0.016	0.013
W.S. Elev (ft)	2113.72	Reach Len. (ft)	318.07	318.07	318.07
Crit W.S. (ft)	2114.66	Flow Area (sq ft)	5.20	70.33	4.05
E.G. Slope (ft/ft)	0.017287	Area (sq ft)	5.20	70.33	10.72
Q Total (cfs)	1158.00	Flow (cfs)	54.32	1056.76	46.92
Top Width (ft)	83.11	Top Width (ft)	6.00	52.50	24.61
Vel Total (ft/s)	14.55	Avg. Vel. (ft/s)	10.46	15.03	11.57
Max Chl Dpth (ft)	2.02	Hydr. Depth (ft)	0.87	1.34	0.68
Conv. Total (cfs)	8807.4	Conv. (cfs)	413.1	8037.4	356.9
Length Wtd. (ft)	318.07	Wetted Per. (ft)	6.56	53.54	6.00
Min Ch El (ft)	2112.00	Shear (lb/sq ft)	0.86	1.42	0.73
Alpha	1.02	Stream Power (lb/ft s)	8.94	21.30	8.44
Frctn Loss (ft)	4.55	Cum Volume (acre-ft)	0.40	0.79	0.12
C & E Loss (ft)	0.65	Cum SA (acres)	0.58	0.61	0.20

Plan: UP3 SIRIUS AVE SIRIUS RS: 1215 Profile: 100-yr

E.G. Elev (ft)	2111.88	Element	Left OB	Channel	Right OB
Vel Head (ft)	1.20	Wt. n-Val.	0.016	0.015	0.013
W.S. Elev (ft)	2110.68	Reach Len. (ft)	45.00	45.00	45.00
Crit W.S. (ft)	2111.03	Flow Area (sq ft)	72.85	50.88	6.71
E.G. Slope (ft/ft)	0.011836	Area (sq ft)	72.85	50.88	6.71
Q Total (cfs)	1096.19	Flow (cfs)	529.55	522.12	44.51
Top Width (ft)	191.50	Top Width (ft)	119.00	55.50	17.00
Vel Total (ft/s)	8.40	Avg. Vel. (ft/s)	7.27	10.26	6.63
Max Chl Dpth (ft)	1.42	Hydr. Depth (ft)	0.61	0.92	0.39
Conv. Total (cfs)	10075.7	Conv. (cfs)	4867.4	4799.1	409.2
Length Wtd. (ft)		Wetted Per. (ft)	119.38	55.95	17.23
Min Ch El (ft)	2109.25	Shear (lb/sq ft)	0.45	0.67	0.29
Alpha	1.10	Stream Power (lb/ft s)	3.28	6.90	1.91
Frctn Loss (ft)		Cum Volume (acre-ft)	0.11	0.35	0.06
C & E Loss (ft)		Cum SA (acres)	0.13	0.21	0.05

Plan: UP3 SIRIUS AVE SIRIUS RS: 1170 Profile: 100-yr

E.G. Elev (ft)	2111.61	Element	Left OB	Channel	Right OB
Vel Head (ft)	0.66	Wt. n-Val.	0.016	0.016	0.016
W.S. Elev (ft)	2110.95	Reach Len. (ft)	10.00	10.00	10.00
Crit W.S. (ft)	2110.95	Flow Area (sq ft)	55.20	87.86	22.99
E.G. Slope (ft/ft)	0.003065	Area (sq ft)	55.20	87.86	22.99
Q Total (cfs)	1046.78	Flow (cfs)	277.86	630.75	138.17
Top Width (ft)	126.18	Top Width (ft)	56.95	52.23	17.00
Vel Total (ft/s)	6.30	Avg. Vel. (ft/s)	5.03	7.18	6.01
Max Chl Dpth (ft)	2.05	Hydr. Depth (ft)	0.97	1.68	1.35
Conv. Total (cfs)	18907.8	Conv. (cfs)	5018.9	11393.2	2495.7
Length Wtd. (ft)	10.00	Wetted Per. (ft)	56.98	53.25	18.19
Min Ch El (ft)	2108.90	Shear (lb/sq ft)	0.19	0.32	0.24
Alpha	1.07	Stream Power (lb/ft s)	0.93	2.27	1.45
Frctn Loss (ft)	0.06	Cum Volume (acre-ft)	0.05	0.28	0.04
C & E Loss (ft)	0.10	Cum SA (acres)	0.04	0.16	0.03

Plan: UP3 SIRIUS AVE SIRIUS RS: 1160 Profile: 100-yr

E.G. Elev (ft)	2111.45	Element	Left OB	Channel	Right OB
Vel Head (ft)	1.70	Wt. n-Val.	0.016	0.016	0.016
W.S. Elev (ft)	2109.75	Reach Len. (ft)	124.00	124.00	124.00
Crit W.S. (ft)	2110.23	Flow Area (sq ft)	11.47	78.38	11.47
E.G. Slope (ft/ft)	0.008017	Area (sq ft)	11.47	78.38	11.47
Q Total (cfs)	1046.78	Flow (cfs)	97.76	851.27	97.76
Top Width (ft)	71.50	Top Width (ft)	10.00	51.50	10.00
Vel Total (ft/s)	10.33	Avg. Vel. (ft/s)	8.52	10.86	8.52
Max Chl Dpth (ft)	1.75	Hydr. Depth (ft)	1.15	1.52	1.15
Conv. Total (cfs)	11690.9	Conv. (cfs)	1091.8	9507.4	1091.8
Length Wtd. (ft)		Wetted Per. (ft)	11.05	52.52	11.05
Min Ch El (ft)	2108.00	Shear (lb/sq ft)	0.52	0.75	0.52
Alpha	1.03	Stream Power (lb/ft s)	4.43	8.11	4.43
Frctn Loss (ft)		Cum Volume (acre-ft)	0.04	0.26	0.04
C & E Loss (ft)		Cum SA (acres)	0.03	0.15	0.03

Plan: UP3 SIRIUS AVE SIRIUS RS: 1036 Profile: 100-yr

E.G. Elev (ft)	2111.17	Element	Left OB	Channel	Right OB
Vel Head (ft)	0.95	Wt. n-Val.	0.016	0.016	0.016
W.S. Elev (ft)	2110.23	Reach Len. (ft)			
Crit W.S. (ft)	2110.23	Flow Area (sq ft)	16.28	103.17	16.28
E.G. Slope (ft/ft)	0.003089	Area (sq ft)	16.28	103.17	16.28
Q Total (cfs)	1046.78	Flow (cfs)	105.76	835.26	105.76
Top Width (ft)	71.50	Top Width (ft)	10.00	51.50	10.00
Vel Total (ft/s)	7.71	Avg. Vel. (ft/s)	6.50	8.10	6.50
Max Chl Dpth (ft)	2.23	Hydr. Depth (ft)	1.63	2.00	1.63
Conv. Total (cfs)	18833.9	Conv. (cfs)	1902.9	15028.2	1902.9
Length Wtd. (ft)		Wetted Per. (ft)	11.53	52.52	11.53
Min Ch El (ft)	2108.00	Shear (lb/sq ft)	0.27	0.38	0.27
Alpha	1.02	Stream Power (lb/ft s)	1.77	3.07	1.77
Frctn Loss (ft)		Cum Volume (acre-ft)			
C & E Loss (ft)		Cum SA (acres)			

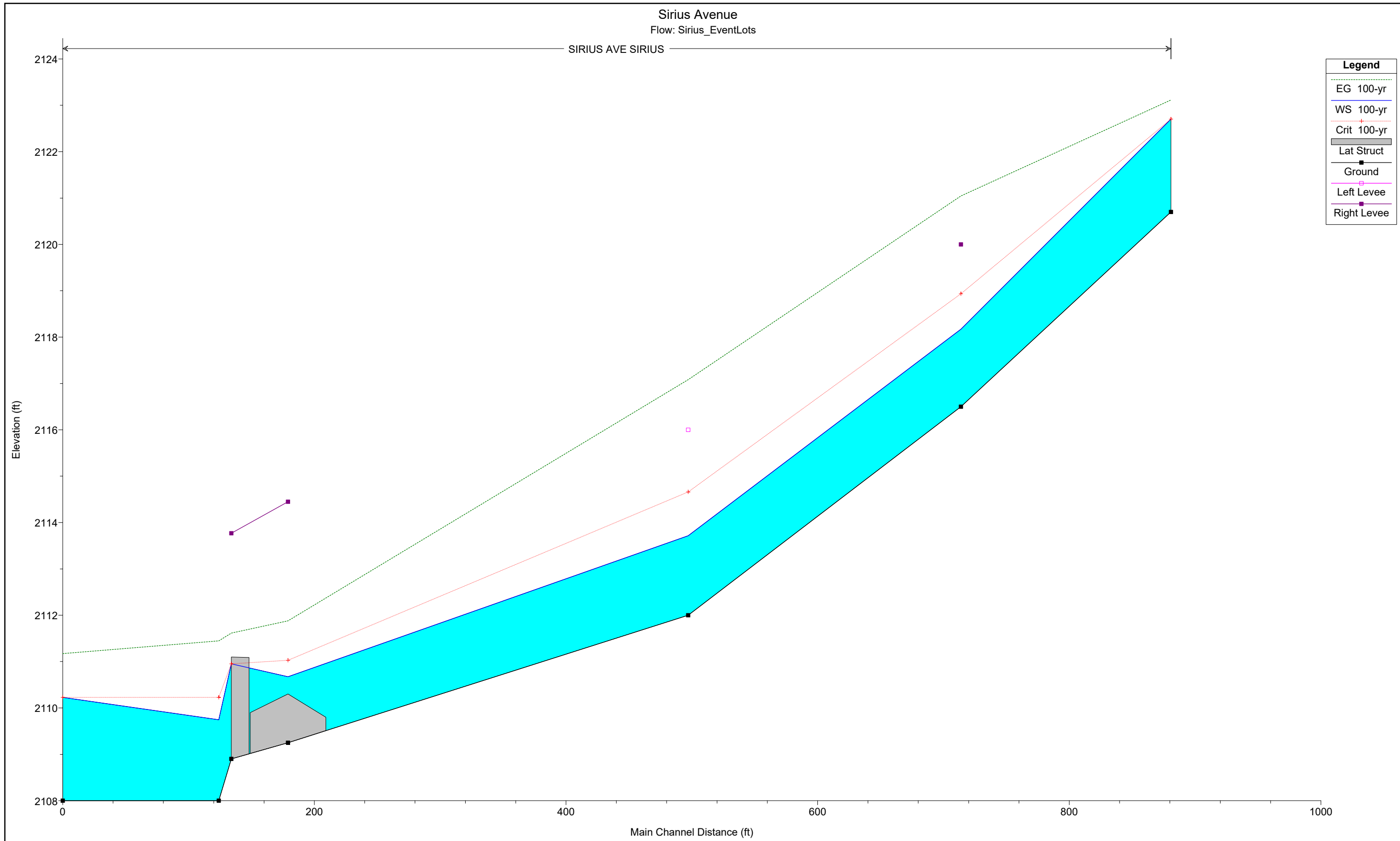

Sirius Avenue
Flow: Sirius_EventLots

Legend

- WS 100-yr
- Ground
- Bank Sta
- Levee
- Ineff

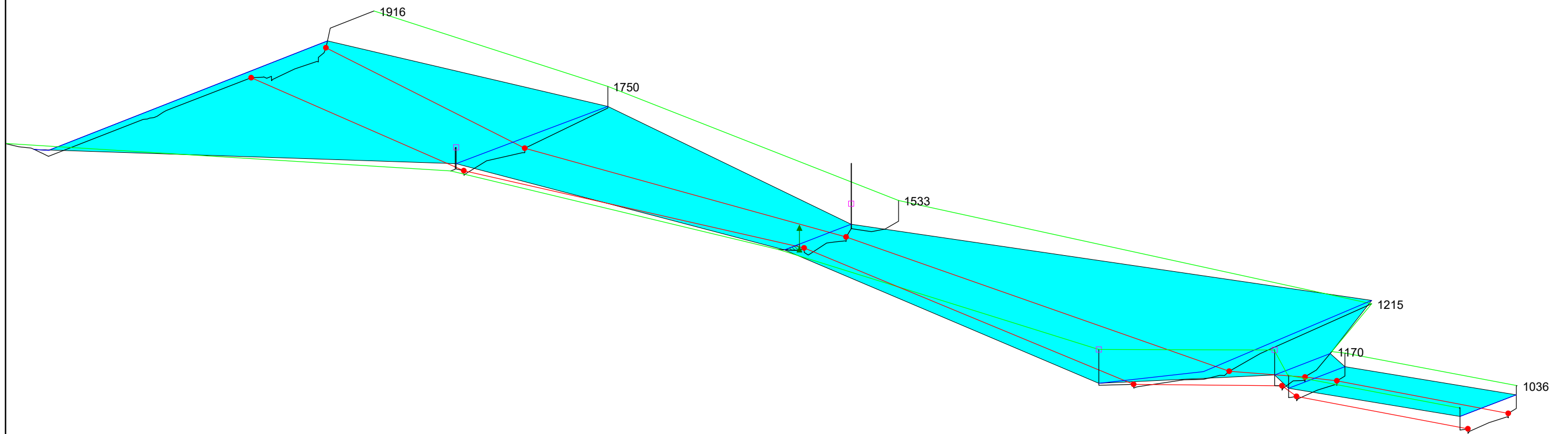

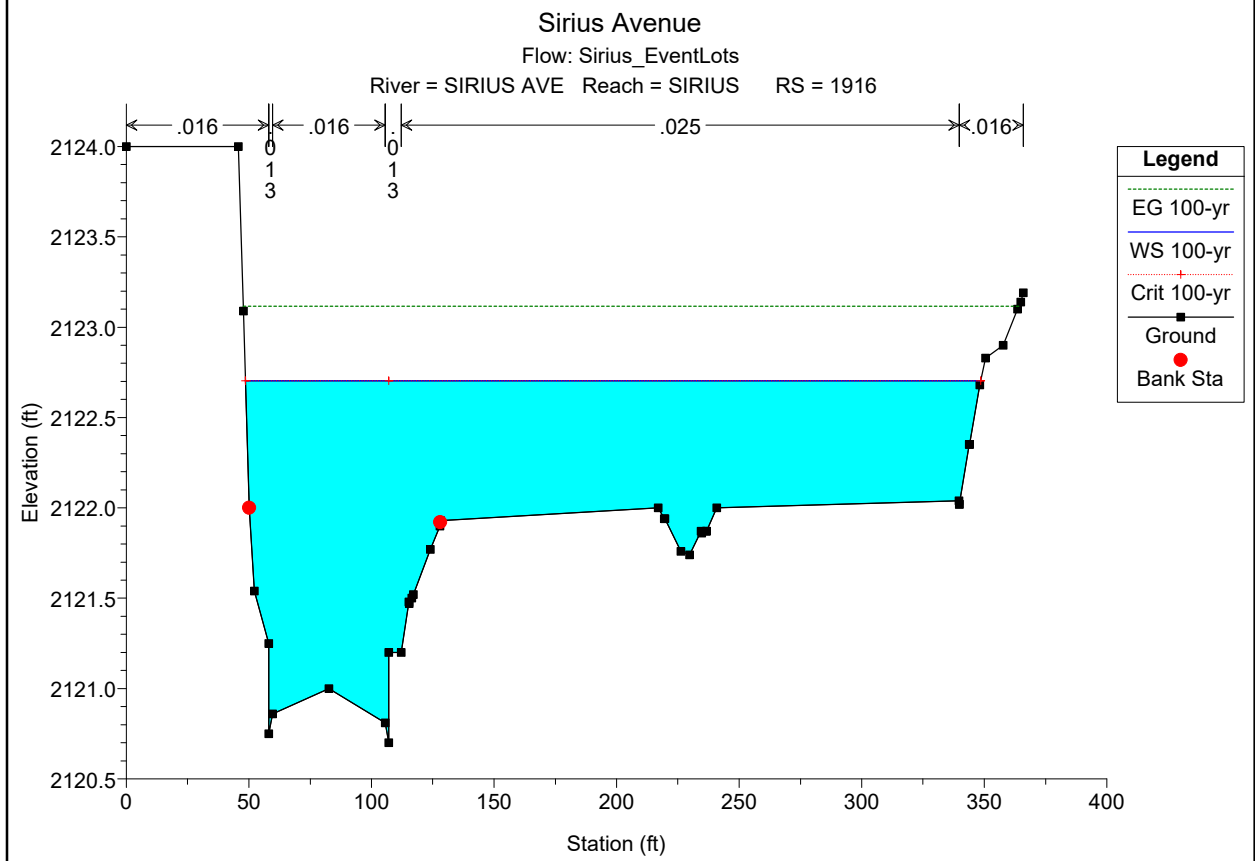
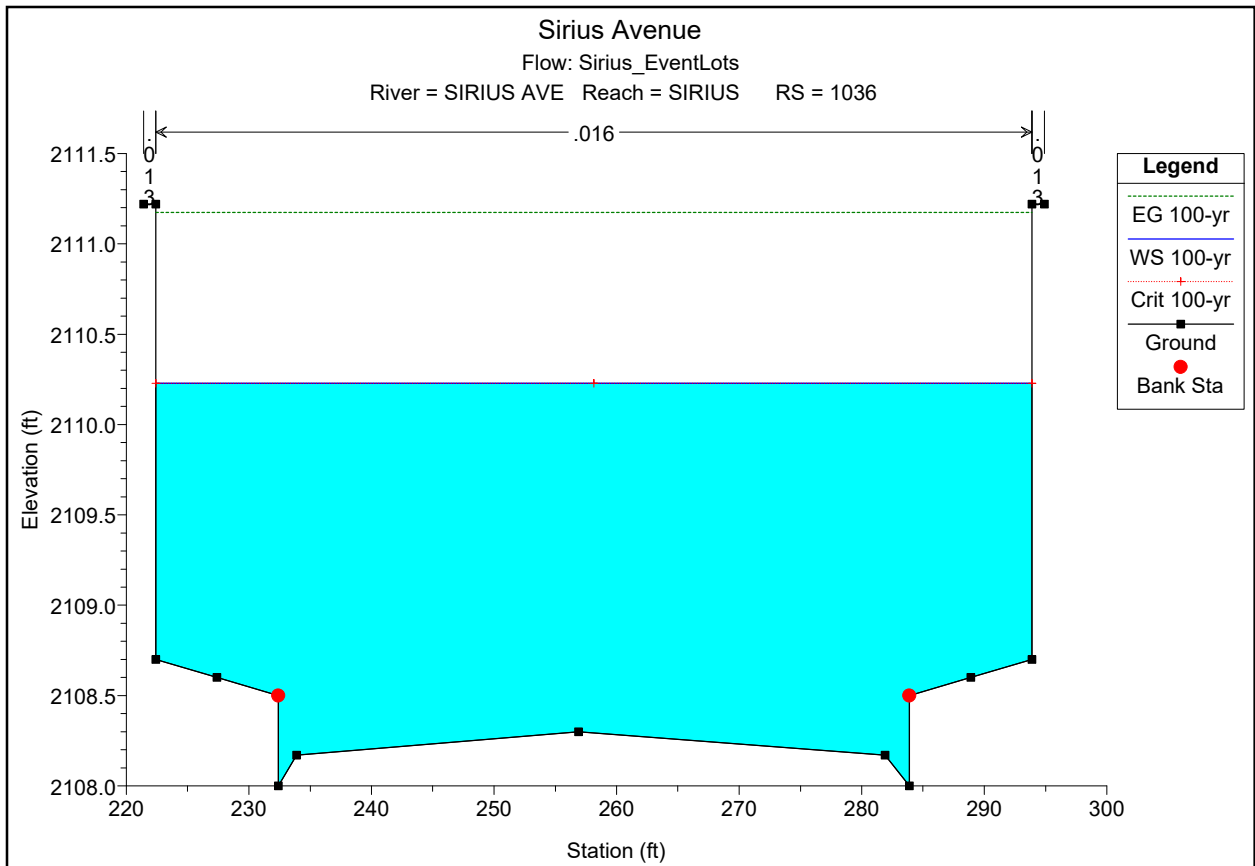

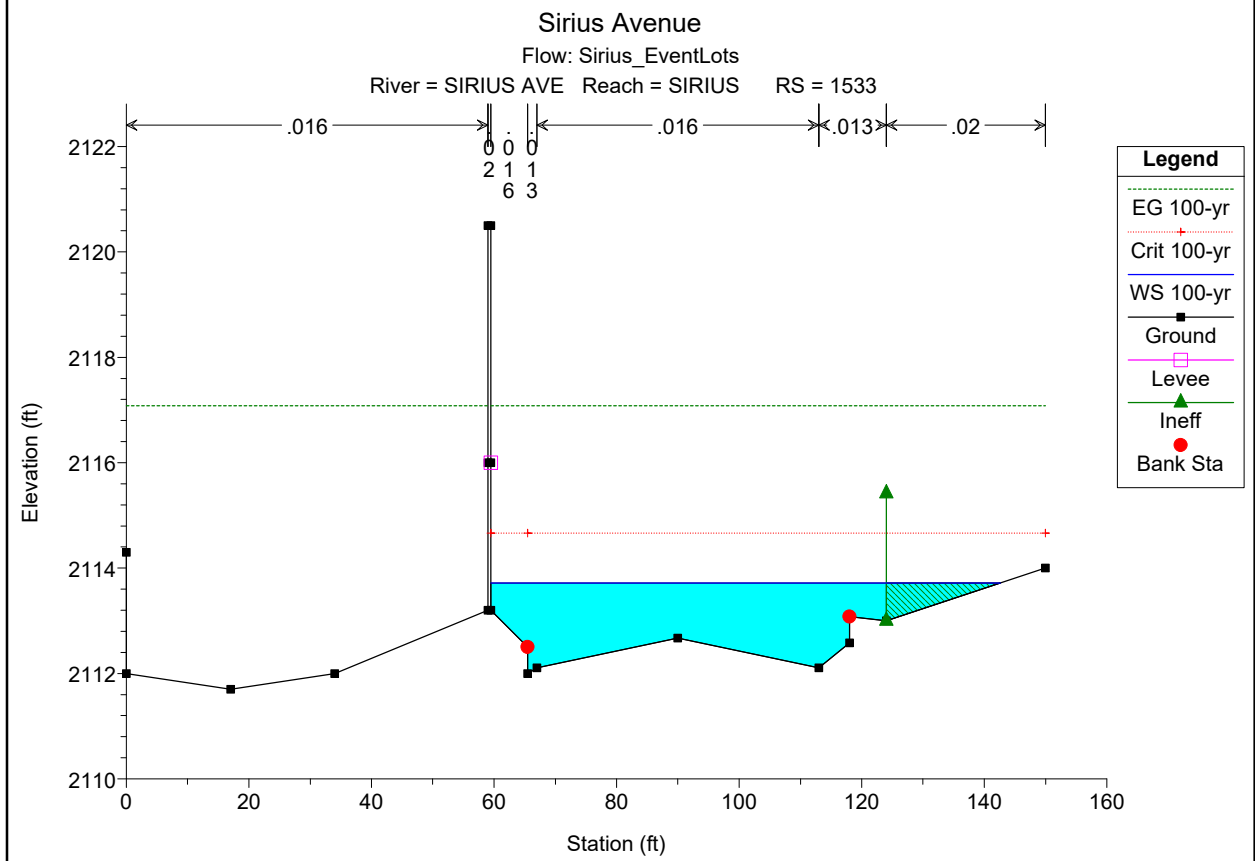
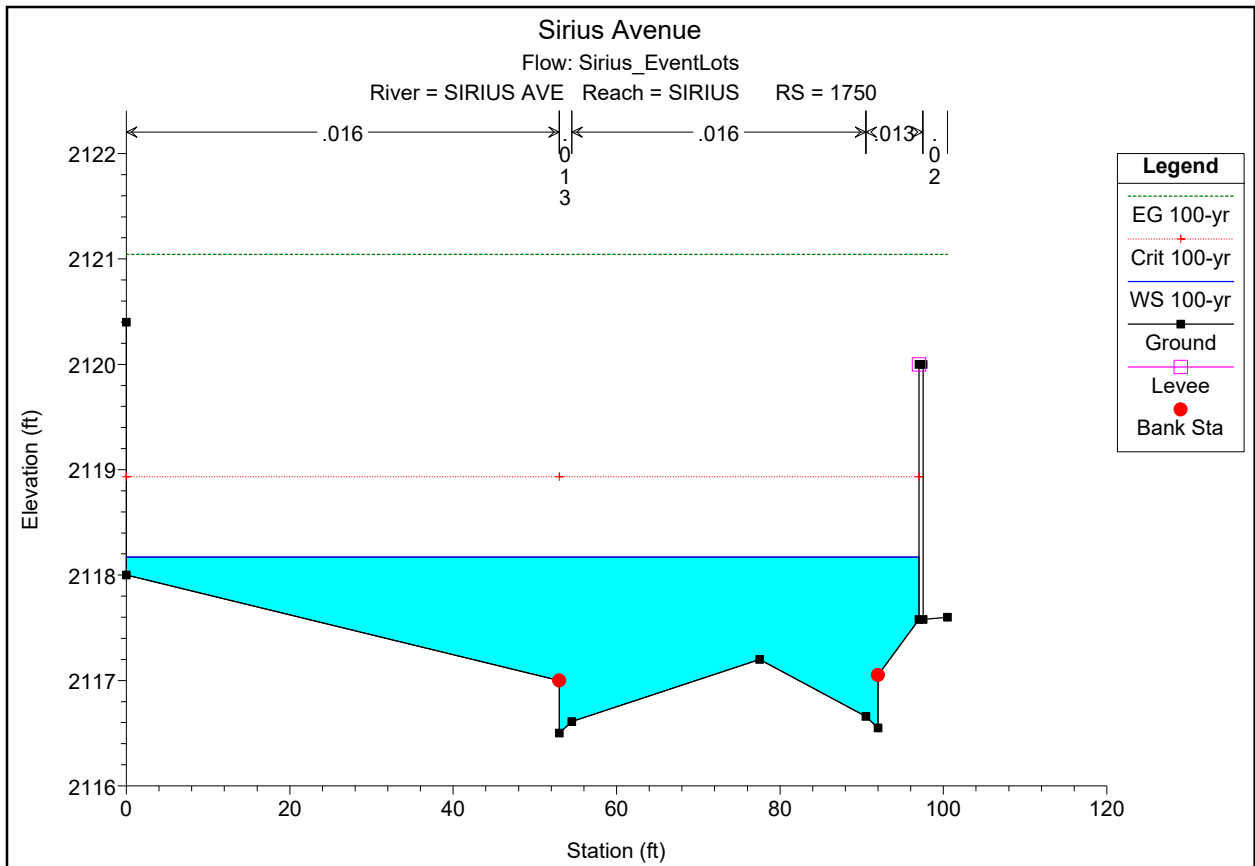

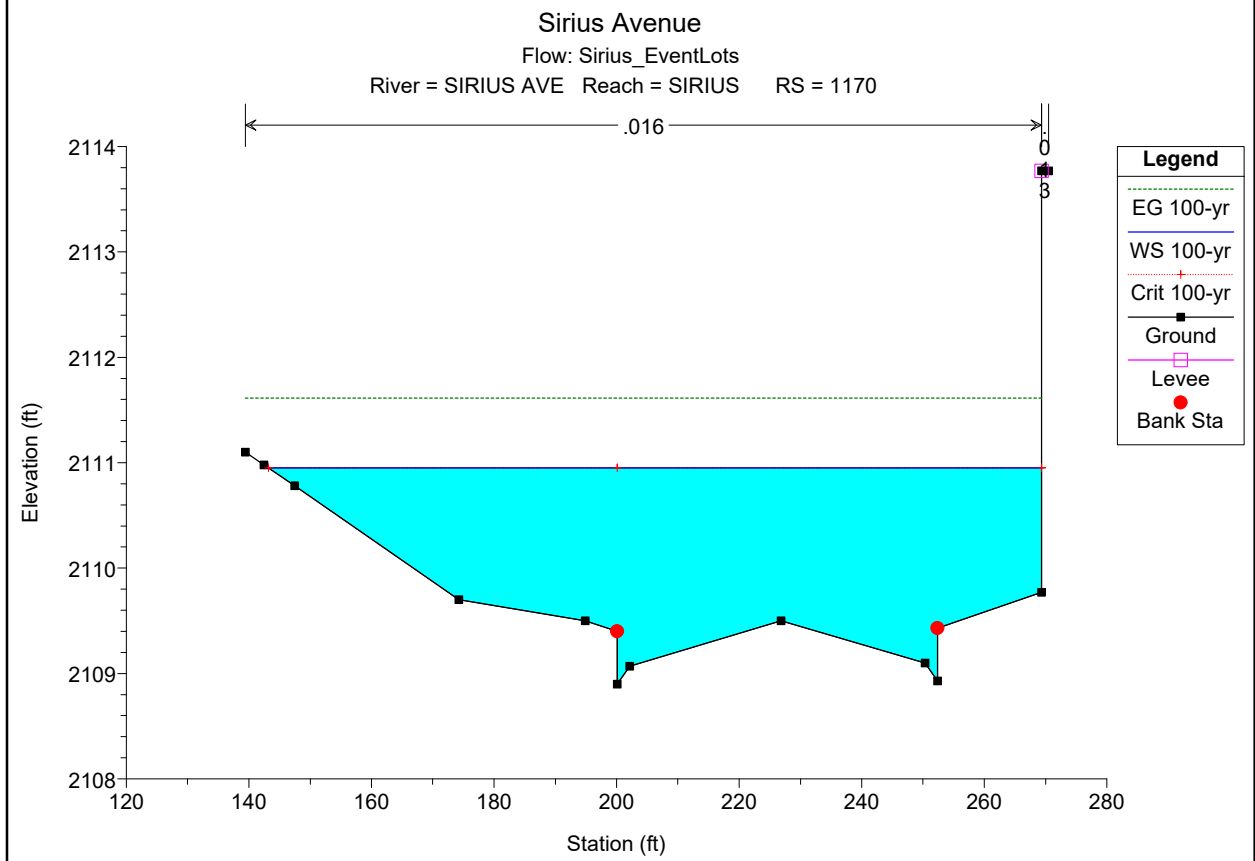
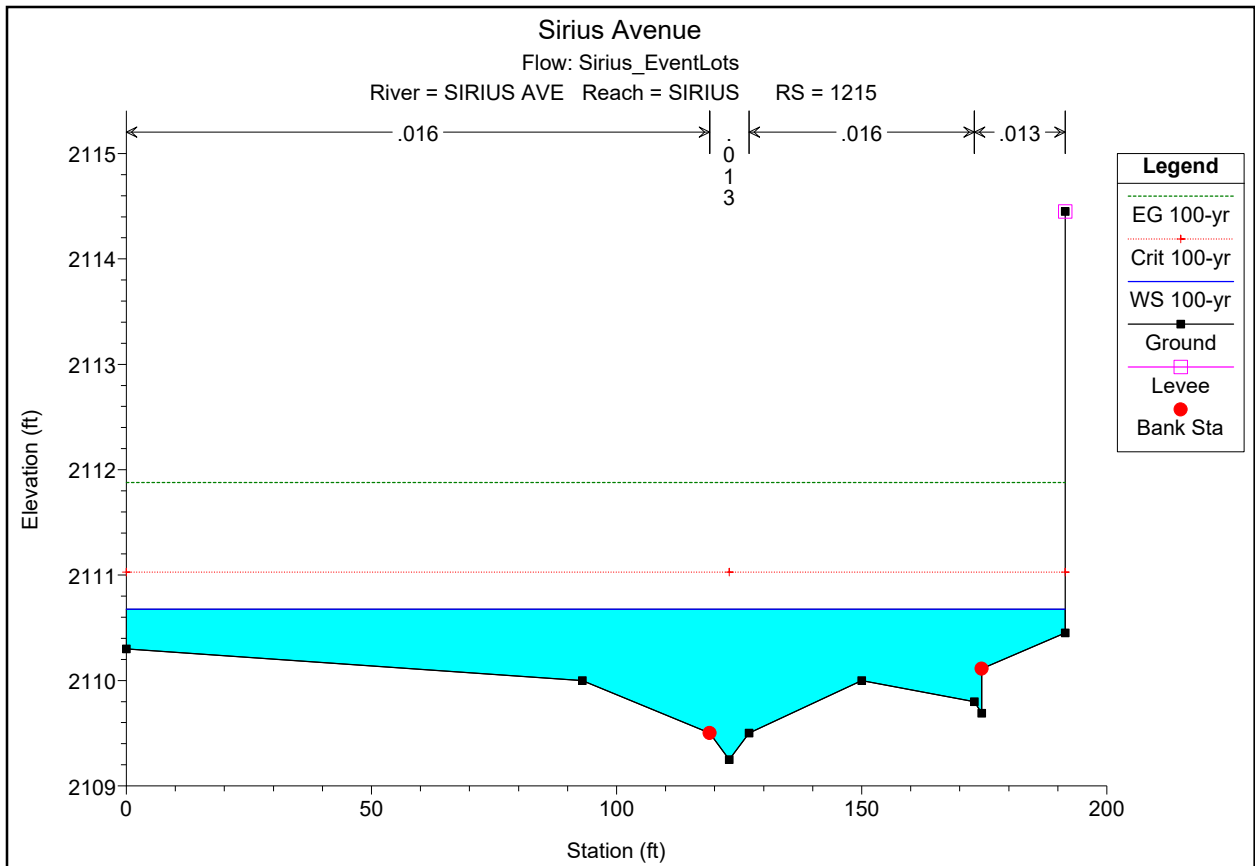

Sirius Avenue

Flow: Sirius_EventLots

River = SIRIUS AVE Reach = SIRIUS RS = 1160

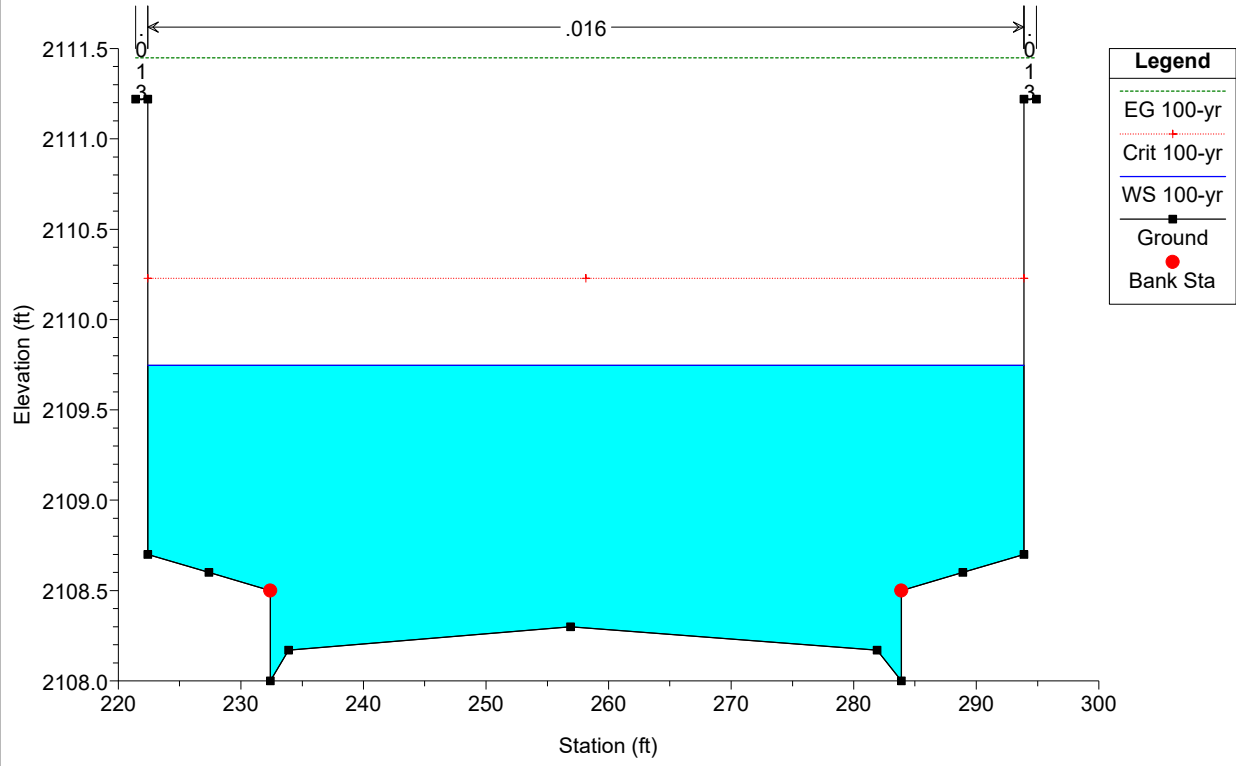

HEC-RAS Plan: UP3 River: SIRIUS AVE Reach: SIRIUS Profile: 100-yr

Reach	River Sta	Profile	Q US (cfs)	Q Leaving Total (cfs)	Q DS (cfs)	Q Weir (cfs)	Q Gates (cfs)	Wr Top Width (ft)	Weir Max Depth (ft)	Weir Avg Depth (ft)	Min El Weir Flow (ft)	E.G. US. (ft)	W.S. US. (ft)	E.G. DS (ft)	W.S. DS (ft)
SIRIUS	1245	100-yr	1158.00	112.88	1046.78	112.88		60.00	1.16	0.72	2109.80	2112.37	2110.96	2111.70	2110.86
SIRIUS	1177	100-yr	1096.19	0.00	1046.78	0.00					2111.09	2111.70	2110.87	2111.61	2110.95

FFE Hydraulic Sections															
SECTION	TRIBUTARY BASINS	SLOPE %	Q ₁₀₀ (cfs)	FLOW DEPTH (ft)	FLOW LINE (ft)	FLOW LINE + 2D (ft)	WSE (ft)	FFE BLDG1 (ft)	FFE BLDG2 (ft)	FFE BLDG3 (ft)	FFE BLDG4 (ft)	FFE BLDG5 (ft)	FFE BLDG6 (ft)	BLDG PROTECTED?	BLDG PROTECTED?
ONH	ONH	2.30	2	0.12	2107.50	2107.74	-	2108.00	2108.00	-	-	-	-	YES	YES
ONP1	ONP	0.77	1.5	0.11	2111.25	2111.47	-	-	-	-	2111.50	-	2111.50	YES	YES
ONP2 South	ONP	1.12	1.5	0.17	2111.30	2111.64	-	-	-	-	-	-	2111.50	**	-
ONP2 North	1/2ONP	0.10	1.5	0.23	2107.50	2107.96	-	2108.00	-	-	-	-	-	YES	-
ONR1	ONR	0.50	0.5	0.10	2110.95	2111.15	-	-	-	-	2111.50	-	2111.50	**	**
ONR2	ONR	1.68	0.5	0.10	2110.80	2111.00	-	-	-	-	2111.50	2111.40	-	YES	YES
RD	**CRCPS06 + ONP + ONL + ONM + ONQ + ONR + ONS + ONT + ONV + ONW + ***RD	0.25	2548	8.56	-	-	2108.42	2108.00	-	-	-	-	-	*	-
ST2	**CRCPS06 + ONR + ONS + ONT + ONV + ONW + ***RD	0.90	2543	6.35	-	-	2108.06	-	-	-	-	-	2111.50	YES	-
*F-F(ROAD)	**CRCPS06 + ONV	0.70	2539	3.59	-	-	2110.58	-	-	-	-	2111.40	-	YES	-
RA	**PS08(OFF1) + 113-cfs + ONG + ONK + ONN + ONO + ONU	0.45	135.5	0.96	2108.65	2111.11	-	-	-	-	2111.50	-	-	YES	-
RA1	**PS08(OFF1) + 113-cfs + ONC + ONG + ONK + ONN + ONO + ONU + 1/2OF5 + 1/2RA	0.68	138.5	1.44	2107.60	2110.54	-	-	2108.00	-	-	-	-	*	-
MA2A	**PS08(OFF1) + **PS08(OFF3) + **PS08(OFF5) + 113-cfs + ONA + ONB + ONC + OND + ONE + ONF + ONG + ONH + ONK + ONN + ONO + ONU + ONX + RA	0.30	230.5	1.30	2102.30	2105.10	-	2108.00	-	-	-	-	-	YES	-
MA2B	**PS08(OFF1) + **PS08(OFF3) + **PS08(OFF5) + 113-cfs + ONA + ONB + ONC + OND + ONE + ONG + ONH + ONK + ONN + ONO + ONU + RA	0.51	228.5	1.12	2101.90	2104.52	-	2108.00	-	-	-	-	-	YES	-
MA2C	**PS08(OFF1) + **PS08(OFF3) + **PS08(OFF5) + 113-cfs + ONA + ONB + ONC + OND + ONG + ONK + ONN + ONO + ONU + RA	1.40	226	0.92	2105.61	2108.03	-	-	2108.00	-	-	-	-	*	-

*Solid Grouted Flood Walls have been provided adjacent to building

**Trench Drains have been provided adjacent to building