

## **Appendix B – Hydraulic Calculations**

- Normal Depth Calculations – Proposed Conditions Street Sections
- Normal Depth Calculations - Onsite Sections
- Normal Depth Sections – Swales
- Normal Depth Sections – Block Wall Openings
- Emergency Overflow Calculations
- Trench Drain Calculations
- Nomographs
- Full Flow Capacity Rating Table
- HEC-RAS Proposed Conditions Analysis (SiriusAve.prj) (On Data CD)
  - Proposed Conditions Report
  - Summary Tables
  - Reach Profile
  - Cross Sections
  - Lateral Weir Summary Tables
- Finished Floor Elevation Table

## Worksheet for ST1.5

Project Description	
Friction Method	Manning Formula
Solve For	Normal Depth

---

Input Data	
Channel Slope	0.41 %
Discharge	2,543.50 cfs

### Section Definitions

Station (ft)	Elevation (ft)
0+15.67	2,110.93
0+15.67	2,106.93
0+25.67	2,106.73
0+26.17	2,106.23
0+27.72	2,106.36
0+46.41	2,106.81
0+67.42	2,106.20
0+67.46	2,106.66
0+71.50	2,107.12
0+81.85	2,102.45
0+87.55	2,102.45
0+98.18	2,108.42

### Roughness Segment Definitions

Start Station	Ending Station	Roughness Coefficient
(0+15.67, 2,110.93)	(0+26.17, 2,106.23)	0.013
(0+26.17, 2,106.23)	(0+67.42, 2,106.20)	0.016
(0+67.42, 2,106.20)	(0+71.50, 2,107.12)	0.013
(0+71.50, 2,107.12)	(0+87.55, 2,102.45)	0.025
(0+87.55, 2,102.45)	(0+98.18, 2,108.42)	0.038

### Options

Current Roughness Weighted Method	Pavlovskii's Method
Open Channel Weighting Method	Pavlovskii's Method
Closed Channel Weighting Method	Pavlovskii's Method

### Results

Normal Depth	6.84 ft
Roughness Coefficient	0.022
Elevation	2,109.29 ft
Elevation Range	2,102.45 to 2,110.93 ft
Flow Area	276.3 ft <sup>2</sup>

## Worksheet for ST1.5

---

### Results

---

Wetted Perimeter	88.99 ft
Hydraulic Radius	3.10 ft
Top Width	82.51 ft
Normal Depth	6.84 ft
Critical Depth	6.58 ft
Critical Slope	0.53 %
Velocity	9.21 ft/s
Velocity Head	1.32 ft
Specific Energy	8.16 ft
Froude Number	0.887
Flow Type	Subcritical

---

### GVF Input Data

---

Downstream Depth	0.00 ft
Length	0.00 ft
Number Of Steps	0

---

### GVF Output Data

---

Upstream Depth	0.00 ft
Profile Description	N/A
Profile Headloss	0.00 ft
Downstream Velocity	Infinity ft/s
Upstream Velocity	Infinity ft/s
Normal Depth	6.84 ft
Critical Depth	6.58 ft
Channel Slope	0.41 %
Critical Slope	0.53 %

---

## Cross Section for ST1.5

Project Description	
Friction Method	Manning Formula
Solve For	Normal Depth

Input Data	
Channel Slope	0.41 %
Normal Depth	6.84 ft
Discharge	2,543.50 cfs

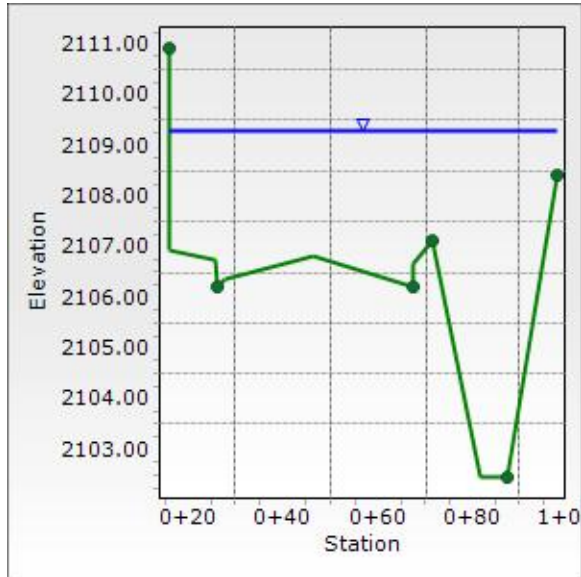

## Worksheet for ST2

Project Description	
Friction Method	Manning Formula
Solve For	Normal Depth

---

Input Data	
Channel Slope	0.90 %
Discharge	2,543.50 cfs

### Section Definitions

	Station (ft)	Elevation (ft)
	0+19.77	2,110.44
	0+19.77	2,106.44
	0+29.77	2,106.23
	0+29.79	2,105.77
	0+29.86	2,105.79
	0+31.15	2,105.89
	0+49.46	2,106.26
	0+68.88	2,105.84
	0+70.33	2,105.69
	0+74.31	2,106.76
	0+84.72	2,102.72
	0+86.09	2,101.71
	0+91.96	2,101.71
	1+07.91	2,108.66

### Roughness Segment Definitions

Start Station	Ending Station	Roughness Coefficient
(0+19.77, 2,110.44)	(0+29.79, 2,105.77)	0.013
(0+29.79, 2,105.77)	(0+70.33, 2,105.69)	0.016
(0+70.33, 2,105.69)	(0+74.31, 2,106.76)	0.013
(0+74.31, 2,106.76)	(0+86.09, 2,101.71)	0.025
(0+86.09, 2,101.71)	(1+07.91, 2,108.66)	0.038

### Options

Current Roughness Weighted Method	Pavlovskii's Method
Open Channel Weighting Method	Pavlovskii's Method
Closed Channel Weighting Method	Pavlovskii's Method

### Results

Normal Depth	6.35 ft
Roughness Coefficient	0.024
Elevation	2,108.06 ft

## Worksheet for ST2

---

### Results

---

Elevation Range	2,101.71 to 2,110.44 ft
Flow Area	232.4 ft <sup>2</sup>
Wetted Perimeter	91.40 ft
Hydraulic Radius	2.54 ft
Top Width	86.76 ft
Normal Depth	6.35 ft
Critical Depth	6.67 ft
Critical Slope	0.63 %
Velocity	10.95 ft/s
Velocity Head	1.86 ft
Specific Energy	8.21 ft
Froude Number	1.179
Flow Type	Supercritical

---

### GVF Input Data

---

Downstream Depth	0.00 ft
Length	0.00 ft
Number Of Steps	0

---

### GVF Output Data

---

Upstream Depth	0.00 ft
Profile Description	N/A
Profile Headloss	0.00 ft
Downstream Velocity	Infinity ft/s
Upstream Velocity	Infinity ft/s
Normal Depth	6.35 ft
Critical Depth	6.67 ft
Channel Slope	0.90 %
Critical Slope	0.63 %

---

## Cross Section for ST2

Project Description	
Friction Method	Manning Formula
Solve For	Normal Depth

Input Data	
Channel Slope	0.90 %
Normal Depth	6.35 ft
Discharge	2,543.50 cfs

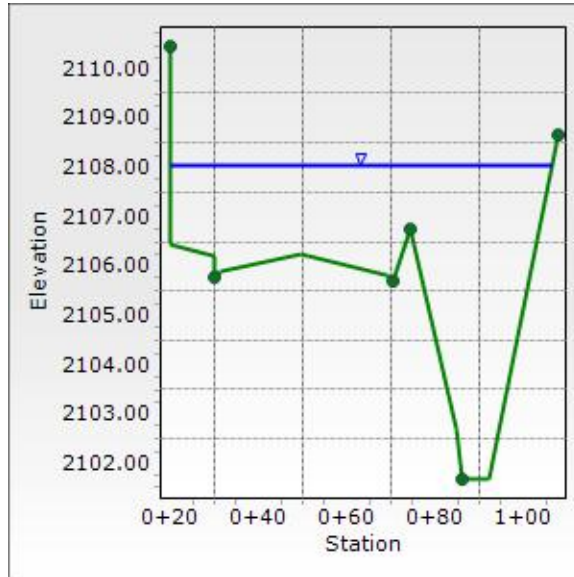

## Worksheet for RD - Rancho 100-Yr

Project Description	
Friction Method	Manning Formula
Solve For	Normal Depth
Input Data	
Channel Slope	0.25 %
Discharge	2,548.00 cfs

### Section Definitions

Station (ft)		Elevation (ft)
	0+00.00	2,108.58
	0+00.00	2,104.88
	0+00.97	2,104.88
	0+05.93	2,104.84
	0+06.35	2,104.83
	0+06.41	2,104.82
	0+06.43	2,104.47
	0+06.43	2,104.41
	0+06.56	2,104.41
	0+07.56	2,104.50
	0+07.59	2,104.50
	0+07.76	2,104.51
	0+23.43	2,104.94
	0+25.97	2,105.00
	0+28.83	2,104.93
	0+45.63	2,104.51
	0+46.93	2,104.37
	0+47.10	2,104.36
	0+47.10	2,104.36
	0+47.12	2,104.77
	0+47.12	2,104.84
	0+47.19	2,104.84
	0+47.60	2,104.86
	0+50.51	2,105.10
	0+51.00	2,105.14
	0+63.02	2,100.04
	0+63.46	2,099.85
	0+63.61	2,099.86
	0+68.17	2,100.09
	0+69.57	2,100.74
	0+77.46	2,104.36
	0+93.46	2,107.36
	1+15.46	2,107.36

### Roughness Segment Definitions

Start Station	Ending Station	Roughness Coefficient
(0+00.00, 2,108.58)	(0+07.56, 2,104.50)	0.013

## Worksheet for RD - Rancho 100-Yr Roughness Segment Definitions

Start Station	Ending Station	Roughness Coefficient
(0+07.56, 2,104.50)	(0+45.63, 2,104.51)	0.016
(0+45.63, 2,104.51)	(0+51.00, 2,105.14)	0.013
(0+51.00, 2,105.14)	(0+68.17, 2,100.09)	0.025
(0+68.17, 2,100.09)	(1+15.46, 2,107.36)	0.038

### Options

Current Roughness Weighted Method	Pavlovskii's Method
Open Channel Weighting Method	Pavlovskii's Method
Closed Channel Weighting Method	Pavlovskii's Method

### Results

Normal Depth	8.56 ft
Roughness Coefficient	0.028
Elevation	2,108.42 ft
Elevation Range	2,099.85 to 2,108.58 ft
Flow Area	421.2 ft <sup>2</sup>
Wetted Perimeter	123.25 ft
Hydraulic Radius	3.42 ft
Top Width	115.46 ft
Normal Depth	8.56 ft
Critical Depth	7.13 ft
Critical Slope	0.86 %
Velocity	6.05 ft/s
Velocity Head	0.57 ft
Specific Energy	9.13 ft
Froude Number	0.558
Flow Type	Subcritical

### GVF Input Data

Downstream Depth	0.00 ft
Length	0.00 ft
Number Of Steps	0

### GVF Output Data

Upstream Depth	0.00 ft
Profile Description	N/A
Profile Headloss	0.00 ft
Downstream Velocity	Infinity ft/s
Upstream Velocity	Infinity ft/s
Normal Depth	8.56 ft
Critical Depth	7.13 ft
Channel Slope	0.25 %
Critical Slope	0.86 %

## Worksheet for ST2.5

Project Description	
Friction Method	Manning Formula
Solve For	Normal Depth

---

Input Data	
Channel Slope	0.90 %
Discharge	2,544.50 cfs

### Section Definitions

	Station (ft)	Elevation (ft)
	0+18.30	2,106.55
	0+18.95	2,105.98
	0+29.66	2,105.82
	0+30.11	2,105.73
	0+34.39	2,105.83
	0+56.65	2,105.77
	0+69.15	2,105.51
	0+70.63	2,105.38
	0+70.73	2,105.78
	0+73.69	2,105.79
	0+74.24	2,105.85
	0+83.89	2,101.62
	0+88.99	2,101.29
	0+90.71	2,101.18
	1+06.66	2,115.13

### Roughness Segment Definitions

Start Station	Ending Station	Roughness Coefficient
(0+18.30, 2,106.55)	(0+30.11, 2,105.73)	0.013
(0+30.11, 2,105.73)	(0+70.63, 2,105.38)	0.016
(0+70.63, 2,105.38)	(0+73.69, 2,105.79)	0.013
(0+73.69, 2,105.79)	(0+90.71, 2,101.18)	0.025
(0+90.71, 2,101.18)	(1+06.66, 2,115.13)	0.038

### Options

Current Roughness Weighted Method	Pavlovskii's Method
Open Channel Weighting Method	Pavlovskii's Method
Closed Channel Weighting Method	Pavlovskii's Method

### Results

Normal Depth	6.48 ft
Roughness Coefficient	0.021
Elevation	2,107.66 ft

## Worksheet for ST2.5

---

### Results

---

Elevation Range	2,101.18 to 2,115.13 ft
Flow Area	210.2 ft <sup>2</sup>
Wetted Perimeter	84.82 ft
Hydraulic Radius	2.48 ft
Top Width	79.82 ft
Normal Depth	6.48 ft
Critical Depth	7.02 ft
Critical Slope	0.50 %
Velocity	12.10 ft/s
Velocity Head	2.28 ft
Specific Energy	8.76 ft
Froude Number	1.315
Flow Type	Supercritical

---

### GVF Input Data

---

Downstream Depth	0.00 ft
Length	0.00 ft
Number Of Steps	0

---

### GVF Output Data

---

Upstream Depth	0.00 ft
Profile Description	N/A
Profile Headloss	0.00 ft
Downstream Velocity	Infinity ft/s
Upstream Velocity	Infinity ft/s
Normal Depth	6.48 ft
Critical Depth	7.02 ft
Channel Slope	0.90 %
Critical Slope	0.50 %

---

## Cross Section for ST2.5

Project Description	
Friction Method	Manning Formula
Solve For	Normal Depth

Input Data	
Channel Slope	0.90 %
Normal Depth	6.48 ft
Discharge	2,544.50 cfs

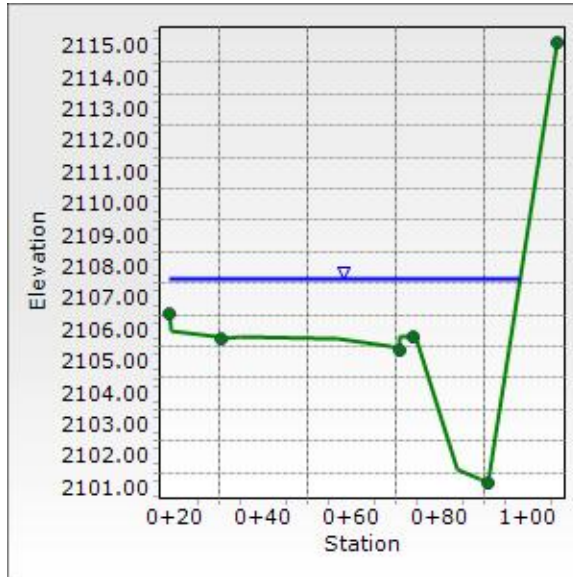

## Cross Section for RD - Rancho 100-Yr

Project Description	
Friction Method	Manning Formula
Solve For	Normal Depth

Input Data	
Channel Slope	0.25 %
Normal Depth	8.56 ft
Discharge	2,548.00 cfs

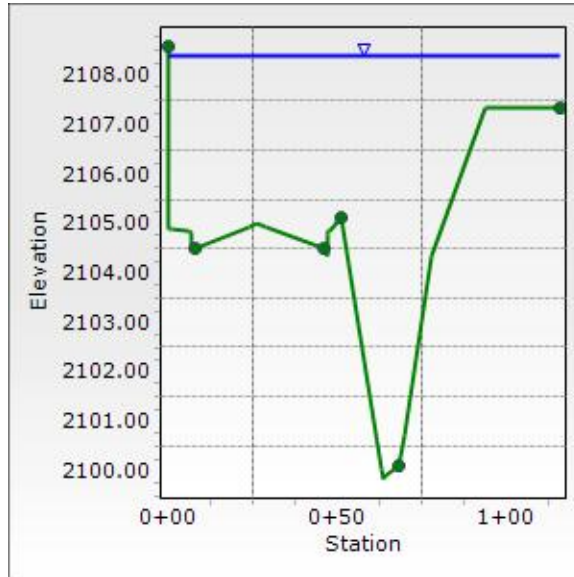

## Worksheet for ST3

Project Description	
Friction Method	Manning Formula
Solve For	Normal Depth

---

Input Data	
Channel Slope	0.67 %
Discharge	2,548.00 cfs

### Section Definitions

Station (ft)	Elevation (ft)
0+22.48	2,106.68
0+22.48	2,103.68
0+32.98	2,103.46
0+32.98	2,103.46
0+32.98	2,102.98
0+34.48	2,103.11
0+34.48	2,103.15
0+52.53	2,103.85
0+73.50	2,103.28
0+77.85	2,104.33
0+89.53	2,098.85
0+91.03	2,098.96
0+95.38	2,099.05
1+13.81	2,109.53

### Roughness Segment Definitions

Start Station	Ending Station	Roughness Coefficient
(0+22.48, 2,106.68)	(0+34.48, 2,103.11)	0.013
(0+34.48, 2,103.11)	(0+73.50, 2,103.28)	0.016
(0+73.50, 2,103.28)	(0+77.85, 2,104.33)	0.013
(0+77.85, 2,104.33)	(0+95.38, 2,099.05)	0.025
(0+95.38, 2,099.05)	(1+13.81, 2,109.53)	0.038

### Options

Current Roughness Weighted Method	Pavlovskii's Method
Open Channel Weighting Method	Pavlovskii's Method
Closed Channel Weighting Method	Pavlovskii's Method

### Results

Normal Depth	6.80 ft
Roughness Coefficient	0.022
Elevation	2,105.65 ft

## Worksheet for ST3

---

### Results

---

Elevation Range	2,098.85 to 2,109.53 ft
Flow Area	240.9 ft <sup>2</sup>
Wetted Perimeter	90.12 ft
Hydraulic Radius	2.67 ft
Top Width	84.50 ft
Normal Depth	6.80 ft
Critical Depth	7.00 ft
Critical Slope	0.54 %
Velocity	10.58 ft/s
Velocity Head	1.74 ft
Specific Energy	8.54 ft
Froude Number	1.104
Flow Type	Supercritical

---

### GVF Input Data

---

Downstream Depth	0.00 ft
Length	0.00 ft
Number Of Steps	0

---

### GVF Output Data

---

Upstream Depth	0.00 ft
Profile Description	N/A
Profile Headloss	0.00 ft
Downstream Velocity	Infinity ft/s
Upstream Velocity	Infinity ft/s
Normal Depth	6.80 ft
Critical Depth	7.00 ft
Channel Slope	0.67 %
Critical Slope	0.54 %

---

## Cross Section for ST3

Project Description	
Friction Method	Manning Formula
Solve For	Normal Depth

Input Data	
Channel Slope	0.67 %
Normal Depth	6.80 ft
Discharge	2,548.00 cfs

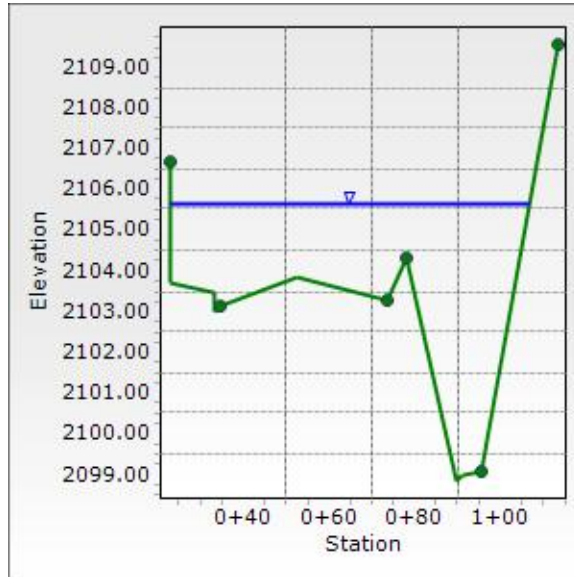

## Worksheet for RA - Rigel 100-Yr

Project Description	
Friction Method	Manning Formula
Solve For	Normal Depth

---

Input Data	
Channel Slope	0.45 %
Discharge	137.50 cfs

### Section Definitions

Station (ft)	Elevation (ft)
0+00.00	0.60
0+05.00	0.50
0+05.00	0.50
0+05.50	0.48
0+05.50	0.00
0+07.00	0.13
0+07.00	0.17
0+30.00	0.63
0+30.00	0.63
0+53.00	0.17
0+53.00	0.13
0+54.50	0.00
0+54.50	0.48
0+55.00	0.50
0+55.00	0.50
0+55.00	0.50
0+60.00	0.60
0+60.00	3.60

### Roughness Segment Definitions

Start Station	Ending Station	Roughness Coefficient
(0+00.00, 0.60)	(0+60.00, 3.60)	0.016

### Options

Current Roughness Weighted Method	Pavlovskii's Method
Open Channel Weighting Method	Pavlovskii's Method
Closed Channel Weighting Method	Pavlovskii's Method

### Results

Normal Depth	0.97 ft
Roughness Coefficient	0.016
Elevation	0.97 ft

## Worksheet for RA - Rigel 100-Yr

---

### Results

---

Elevation Range	0.00 to 3.60 ft
Flow Area	33.3 ft <sup>2</sup>
Wetted Perimeter	61.79 ft
Hydraulic Radius	0.54 ft
Top Width	60.00 ft
Normal Depth	0.97 ft
Critical Depth	0.96 ft
Critical Slope	0.47 %
Velocity	4.13 ft/s
Velocity Head	0.26 ft
Specific Energy	1.23 ft
Froude Number	0.976
Flow Type	Subcritical

---

### GVF Input Data

---

Downstream Depth	0.00 ft
Length	0.00 ft
Number Of Steps	0

---

### GVF Output Data

---

Upstream Depth	0.00 ft
Profile Description	N/A
Profile Headloss	0.00 ft
Downstream Velocity	Infinity ft/s
Upstream Velocity	Infinity ft/s
Normal Depth	0.97 ft
Critical Depth	0.96 ft
Channel Slope	0.45 %
Critical Slope	0.47 %

---

## Cross Section for RA - Rigel 100-Yr

Project Description	
Friction Method	Manning Formula
Solve For	Normal Depth
Input Data	
Channel Slope	0.45 %
Normal Depth	0.97 ft
Discharge	137.50 cfs

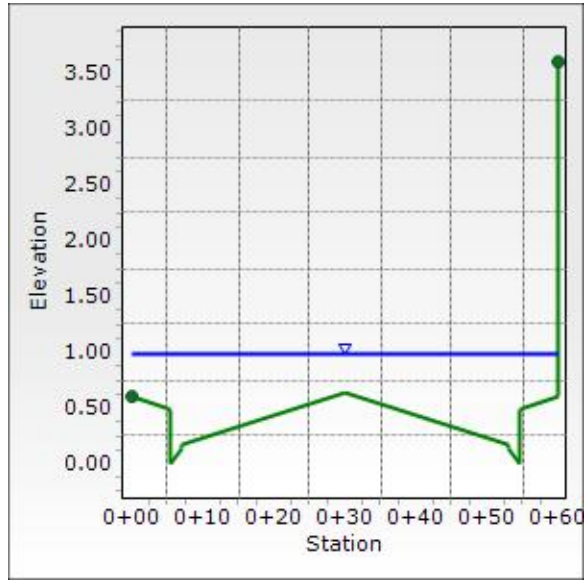

## Worksheet for RA-1 - Rigel 100-Yr

Project Description	
Friction Method	Manning Formula
Solve For	Normal Depth

---

Input Data	
Channel Slope	0.68 %
Discharge	140.50 cfs

### Section Definitions

	Station (ft)	Elevation (ft)
	0+00.00	2.90
	0+05.00	2.80
	0+05.50	2.78
	0+05.50	2.30
	0+07.00	2.43
	0+07.00	2.47
	0+53.00	0.17
	0+53.00	0.13
	0+54.50	0.00
	0+54.50	0.48
	0+55.00	0.50
	0+55.00	0.50
	0+60.00	0.60
	0+60.00	3.60

### Roughness Segment Definitions

Start Station	Ending Station	Roughness Coefficient
(0+00.00, 2.90)	(0+60.00, 3.60)	0.016

### Options

Current Roughness Weighted Method	Pavlovskii's Method
Open Channel Weighting Method	Pavlovskii's Method
Closed Channel Weighting Method	Pavlovskii's Method

### Results

Normal Depth	1.45 ft
Roughness Coefficient	0.016
Elevation	1.45 ft
Elevation Range	0.00 to 3.60 ft
Flow Area	23.5 ft <sup>2</sup>
Wetted Perimeter	34.04 ft
Hydraulic Radius	0.69 ft

## Worksheet for RA-1 - Rigel 100-Yr

---

### Results

---

Top Width	32.63 ft
Normal Depth	1.45 ft
Critical Depth	1.58 ft
Critical Slope	0.43 %
Velocity	5.98 ft/s
Velocity Head	0.56 ft
Specific Energy	2.01 ft
Froude Number	1.243
Flow Type	Supercritical

---

### GVF Input Data

---

Downstream Depth	0.00 ft
Length	0.00 ft
Number Of Steps	0

---

### GVF Output Data

---

Upstream Depth	0.00 ft
Profile Description	N/A
Profile Headloss	0.00 ft
Downstream Velocity	Infinity ft/s
Upstream Velocity	Infinity ft/s
Normal Depth	1.45 ft
Critical Depth	1.58 ft
Channel Slope	0.68 %
Critical Slope	0.43 %

---

## Cross Section for RA-1 - Rigel 100-Yr

Project Description	
Friction Method	Manning Formula
Solve For	Normal Depth
Input Data	
Channel Slope	0.68 %
Normal Depth	1.45 ft
Discharge	140.50 cfs

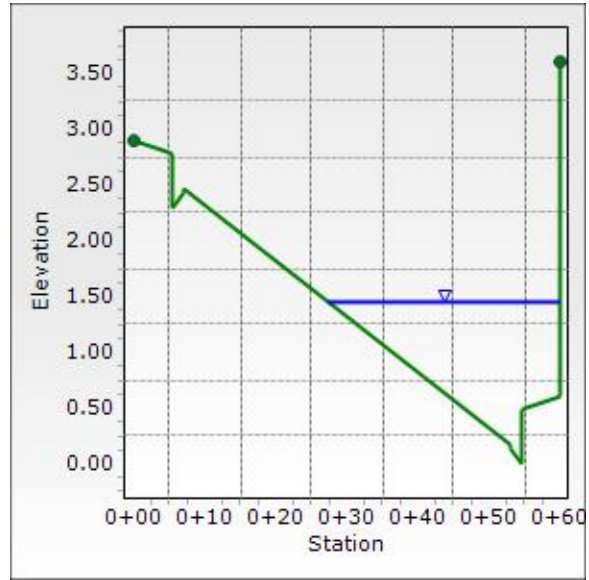

## Worksheet for RA-2 - Rigel 100-Yr

Project Description	
Friction Method	Manning Formula
Solve For	Normal Depth

---

Input Data	
Channel Slope	0.60 %
Discharge	143.00 cfs

### Section Definitions

	Station (ft)	Elevation (ft)
	0+00.00	5.91
	0+00.00	2.91
	0+05.00	2.81
	0+05.50	2.79
	0+05.50	2.31
	0+07.00	2.44
	0+07.00	2.47
	0+53.00	0.17
	0+53.00	0.13
	0+54.50	0.00
	0+54.50	0.48
	0+55.00	0.50
	0+55.00	0.50
	0+60.00	0.60
	0+60.00	3.60

### Roughness Segment Definitions

Start Station	Ending Station	Roughness Coefficient
(0+00.00, 5.91)	(0+60.00, 3.60)	0.016

### Options

Current Roughness Weighted Method	Pavlovskii's Method
Open Channel Weighting Method	Pavlovskii's Method
Closed Channel Weighting Method	Pavlovskii's Method

### Results

Normal Depth	1.49 ft
Roughness Coefficient	0.016
Elevation	1.49 ft
Elevation Range	0.00 to 5.91 ft
Flow Area	24.9 ft <sup>2</sup>
Wetted Perimeter	34.94 ft

## Worksheet for RA-2 - Rigel 100-Yr

---

### Results

---

Hydraulic Radius	0.71 ft
Top Width	33.49 ft
Normal Depth	1.49 ft
Critical Depth	1.59 ft
Critical Slope	0.43 %
Velocity	5.74 ft/s
Velocity Head	0.51 ft
Specific Energy	2.01 ft
Froude Number	1.173
Flow Type	Supercritical

---

### GVF Input Data

---

Downstream Depth	0.00 ft
Length	0.00 ft
Number Of Steps	0

---

### GVF Output Data

---

Upstream Depth	0.00 ft
Profile Description	N/A
Profile Headloss	0.00 ft
Downstream Velocity	Infinity ft/s
Upstream Velocity	Infinity ft/s
Normal Depth	1.49 ft
Critical Depth	1.59 ft
Channel Slope	0.60 %
Critical Slope	0.43 %

---

## Cross Section for RA-2 - Rigel 100-Yr

Project Description	
Friction Method	Manning Formula
Solve For	Normal Depth
Input Data	
Channel Slope	0.60 %
Normal Depth	1.49 ft
Discharge	143.00 cfs

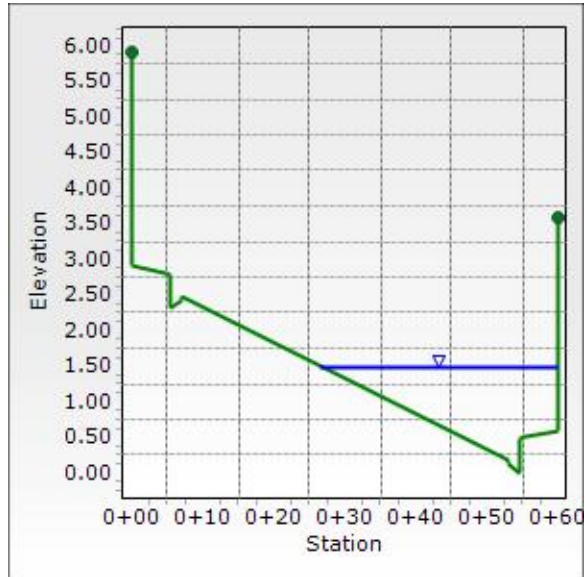

## Worksheet for MA-1 Meade 100-Yr

---

### Project Description

---

Friction Method	Manning Formula
Solve For	Normal Depth

---

### Input Data

---

Channel Slope	3.37 %
Discharge	84.00 cfs

---

### Section Definitions

Station (ft)		Elevation (ft)
	0+00.00	0.72
	0+05.00	0.62
	0+05.50	0.60
	0+05.50	0.12
	0+07.00	0.25
	0+07.00	0.29
	0+30.00	0.68
	0+53.00	0.17
	0+53.00	0.13
	0+54.50	0.00
	0+54.50	0.48
	0+55.00	0.50
	0+60.00	0.60

### Roughness Segment Definitions

Start Station	Ending Station	Roughness Coefficient
(0+00.00, 0.72)	(0+60.00, 0.60)	0.016

---

### Options

---

Current Roughness Weighted Method	Pavlovskii's Method
Open Channel Weighting Method	Pavlovskii's Method
Closed Channel Weighting Method	Pavlovskii's Method

---



---

### Results

---

Normal Depth	0.69 ft
Roughness Coefficient	0.016
Elevation	0.69 ft
Elevation Range	0.00 to 0.72 ft
Flow Area	13.4 ft <sup>2</sup>
Wetted Perimeter	59.55 ft
Hydraulic Radius	0.22 ft
Top Width	58.40 ft

## Worksheet for MA-1 Meade 100-Yr

---

### Results

---

Normal Depth	0.69 ft
Critical Depth	0.86 ft
Critical Slope	0.53 %
Velocity	6.29 ft/s
Velocity Head	0.62 ft
Specific Energy	1.30 ft
Froude Number	2.320
Flow Type	Supercritical

---

### GVF Input Data

---

Downstream Depth	0.00 ft
Length	0.00 ft
Number Of Steps	0

---

### GVF Output Data

---

Upstream Depth	0.00 ft
Profile Description	N/A
Profile Headloss	0.00 ft
Downstream Velocity	Infinity ft/s
Upstream Velocity	Infinity ft/s
Normal Depth	0.69 ft
Critical Depth	0.86 ft
Channel Slope	3.37 %
Critical Slope	0.53 %

---

# Cross Section for MA-1 Meade 100-Yr

Project Description	
Friction Method	Manning Formula
Solve For	Normal Depth

Input Data	
Channel Slope	3.37 %
Normal Depth	0.69 ft
Discharge	84.00 cfs

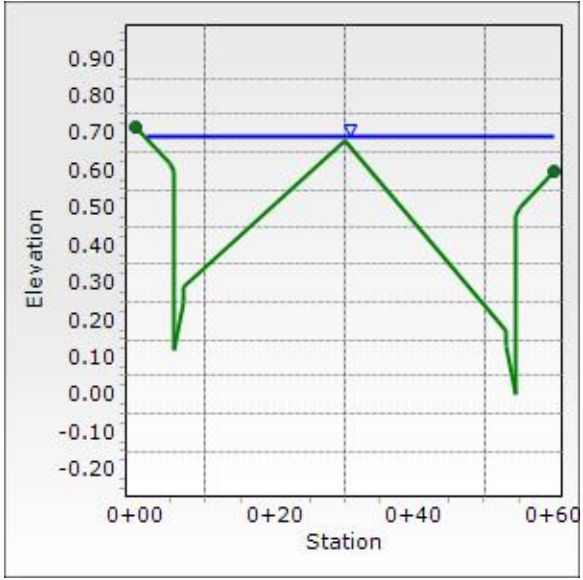

## Worksheet for MA-2A Meade 100-Yr

Project Description	
Friction Method	Manning Formula
Solve For	Normal Depth

---

Input Data	
Channel Slope	0.30 %
Discharge	232.50 cfs

### Section Definitions

	Station (ft)	Elevation (ft)
	0+00.00	0.60
	0+05.00	0.50
	0+05.50	0.48
	0+05.50	0.00
	0+07.00	0.13
	0+07.00	0.17
	0+30.00	0.60
	0+53.00	0.31
	0+53.00	0.27
	0+54.50	0.14
	0+54.50	0.62
	0+55.00	0.64
	0+60.00	0.74

### Roughness Segment Definitions

Start Station	Ending Station	Roughness Coefficient
(0+00.00, 0.60)	(0+60.00, 0.74)	0.016

### Options

Current Roughness Weighted Method	Pavlovskii's Method
Open Channel Weighting Method	Pavlovskii's Method
Closed Channel Weighting Method	Pavlovskii's Method

### Results

Normal Depth	1.30 ft
Roughness Coefficient	0.016
Elevation	1.30 ft
Elevation Range	0.00 to 0.74 ft
Flow Area	51.7 ft <sup>2</sup>
Wetted Perimeter	62.33 ft
Hydraulic Radius	0.83 ft
Top Width	60.00 ft

## Worksheet for MA-2A Meade 100-Yr

---

### Results

---

Normal Depth	1.30 ft
Critical Depth	1.22 ft
Critical Slope	0.43 %
Velocity	4.49 ft/s
Velocity Head	0.31 ft
Specific Energy	1.62 ft
Froude Number	0.853
Flow Type	Subcritical

---

### GVF Input Data

---

Downstream Depth	0.00 ft
Length	0.00 ft
Number Of Steps	0

---

### GVF Output Data

---

Upstream Depth	0.00 ft
Profile Description	N/A
Profile Headloss	0.00 ft
Downstream Velocity	Infinity ft/s
Upstream Velocity	Infinity ft/s
Normal Depth	1.30 ft
Critical Depth	1.22 ft
Channel Slope	0.30 %
Critical Slope	0.43 %

---

# Cross Section for MA-2A Meade 100-Yr

Project Description	
Friction Method	Manning Formula
Solve For	Normal Depth

Input Data	
Channel Slope	0.30 %
Normal Depth	1.30 ft
Discharge	232.50 cfs

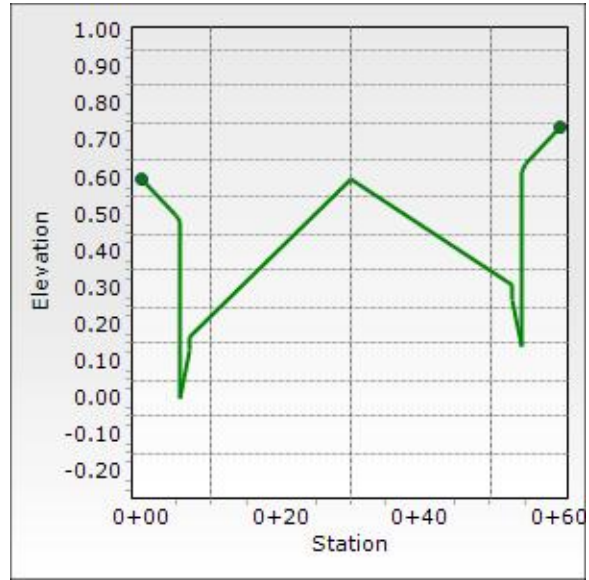

## Worksheet for MA-2B Meade 100-Yr

Project Description	
Friction Method	Manning Formula
Solve For	Normal Depth

---

Input Data	
Channel Slope	0.51 %
Discharge	230.50 cfs

### Section Definitions

	Station (ft)	Elevation (ft)
	0+00.00	0.60
	0+05.00	0.50
	0+05.50	0.48
	0+05.50	0.00
	0+07.00	0.13
	0+07.00	0.17
	0+30.00	0.63
	0+53.00	0.17
	0+53.00	0.13
	0+54.50	0.00
	0+54.50	0.48
	0+55.00	0.50
	0+55.00	0.50
	0+65.00	0.70
	0+65.00	1.10

### Roughness Segment Definitions

Start Station	Ending Station	Roughness Coefficient
(0+00.00, 0.60)	(0+65.00, 1.10)	0.016

### Options

Current Roughness Weighted Method	Pavlovskii's Method
Open Channel Weighting Method	Pavlovskii's Method
Closed Channel Weighting Method	Pavlovskii's Method

### Results

Normal Depth	1.12 ft
Roughness Coefficient	0.016
Elevation	1.12 ft
Elevation Range	0.00 to 1.10 ft
Flow Area	45.2 ft <sup>2</sup>
Wetted Perimeter	67.01 ft

## Worksheet for MA-2B Meade 100-Yr

---

### Results

---

Hydraulic Radius	0.67 ft
Top Width	65.00 ft
Normal Depth	1.12 ft
Critical Depth	1.16 ft
Critical Slope	0.43 %
Velocity	5.10 ft/s
Velocity Head	0.40 ft
Specific Energy	1.53 ft
Froude Number	1.078
Flow Type	Supercritical

---

### GVF Input Data

---

Downstream Depth	0.00 ft
Length	0.00 ft
Number Of Steps	0

---

### GVF Output Data

---

Upstream Depth	0.00 ft
Profile Description	N/A
Profile Headloss	0.00 ft
Downstream Velocity	Infinity ft/s
Upstream Velocity	Infinity ft/s
Normal Depth	1.12 ft
Critical Depth	1.16 ft
Channel Slope	0.51 %
Critical Slope	0.43 %

---

## Cross Section for MA-2B Meade 100-Yr

Project Description	
Friction Method	Manning Formula
Solve For	Normal Depth

Input Data	
Channel Slope	0.51 %
Normal Depth	1.12 ft
Discharge	230.50 cfs

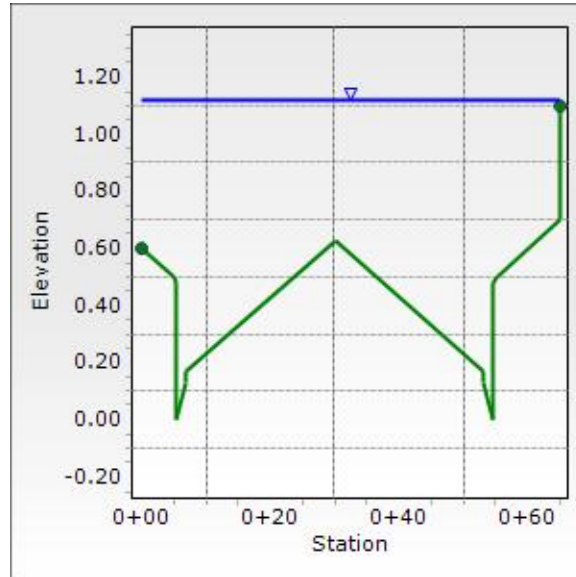

## Worksheet for MA-2C Meade 100-Yr

Project Description	
Friction Method	Manning Formula
Solve For	Normal Depth

---

Input Data	
Channel Slope	1.40 %
Discharge	227.50 cfs

### Section Definitions

	Station (ft)	Elevation (ft)
	0+00.00	0.75
	0+05.00	0.65
	0+05.50	0.63
	0+05.50	0.15
	0+07.00	0.28
	0+07.00	0.32
	0+30.00	0.45
	0+53.00	0.17
	0+53.00	0.13
	0+54.50	0.00
	0+54.50	0.48
	0+55.00	0.50
	0+60.00	0.60

### Roughness Segment Definitions

Start Station	Ending Station	Roughness Coefficient
(0+00.00, 0.75)	(0+60.00, 0.60)	0.016

### Options

Current Roughness Weighted Method	Pavlovskii's Method
Open Channel Weighting Method	Pavlovskii's Method
Closed Channel Weighting Method	Pavlovskii's Method

### Results

Normal Depth	0.92 ft
Roughness Coefficient	0.016
Elevation	0.92 ft
Elevation Range	0.00 to 0.75 ft
Flow Area	32.0 ft <sup>2</sup>
Wetted Perimeter	61.55 ft
Hydraulic Radius	0.52 ft
Top Width	60.00 ft

## Worksheet for MA-2C Meade 100-Yr

---

### Results

---

Normal Depth	0.92 ft
Critical Depth	1.15 ft
Critical Slope	0.43 %
Velocity	7.11 ft/s
Velocity Head	0.79 ft
Specific Energy	1.71 ft
Froude Number	1.716
Flow Type	Supercritical

---

### GVF Input Data

---

Downstream Depth	0.00 ft
Length	0.00 ft
Number Of Steps	0

---

### GVF Output Data

---

Upstream Depth	0.00 ft
Profile Description	N/A
Profile Headloss	0.00 ft
Downstream Velocity	Infinity ft/s
Upstream Velocity	Infinity ft/s
Normal Depth	0.92 ft
Critical Depth	1.15 ft
Channel Slope	1.40 %
Critical Slope	0.43 %

---

# Cross Section for MA-2C Meade 100-Yr

Project Description	
Friction Method	Manning Formula
Solve For	Normal Depth

Input Data	
Channel Slope	1.40 %
Normal Depth	0.92 ft
Discharge	227.50 cfs

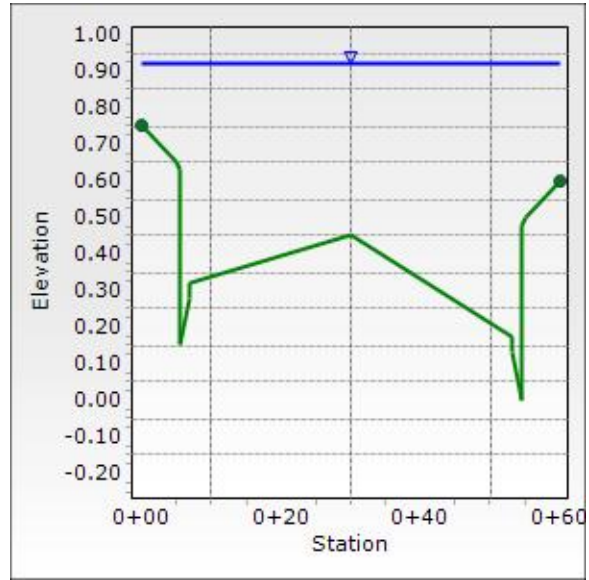

## Worksheet for ONH

---

### Project Description

---

Friction Method	Manning Formula
Solve For	Normal Depth

---

### Input Data

---

Channel Slope	0.61 %
Discharge	2.00 cfs

---

### Section Definitions

	Station (ft)	Elevation (ft)
	0+07.98	2,108.00
	0+66.03	2,107.20
	1+11.28	2,108.00

### Roughness Segment Definitions

Start Station	Ending Station	Roughness Coefficient
(0+07.98, 2,108.00)	(1+11.28, 2,108.00)	0.016

---

### Options

---

Current Roughness Weighted Method	Pavlovskii's Method
Open Channel Weighting Method	Pavlovskii's Method
Closed Channel Weighting Method	Pavlovskii's Method

---



---

### Results

---

Normal Depth	0.15 ft
Roughness Coefficient	0.016
Elevation	2,107.35 ft
Elevation Range	2,107.20 to 2,108.00 ft
Flow Area	1.5 ft <sup>2</sup>
Wetted Perimeter	19.86 ft
Hydraulic Radius	0.08 ft
Top Width	19.85 ft
Normal Depth	0.15 ft
Critical Depth	0.14 ft
Critical Slope	0.90 %
Velocity	1.31 ft/s
Velocity Head	0.03 ft
Specific Energy	0.18 ft
Froude Number	0.833
Flow Type	Subcritical

---



---

### GVF Input Data

---

## Worksheet for ONH

---

### GVF Input Data

---

Downstream Depth	0.00 ft
Length	0.00 ft
Number Of Steps	0

---

### GVF Output Data

---

Upstream Depth	0.00 ft
Profile Description	N/A
Profile Headloss	0.00 ft
Downstream Velocity	0.00 ft/s
Upstream Velocity	0.00 ft/s
Normal Depth	0.15 ft
Critical Depth	0.14 ft
Channel Slope	0.61 %
Critical Slope	0.90 %

---

# Cross Section for ONH

Project Description	
Friction Method	Manning Formula
Solve For	Normal Depth

Input Data	
Channel Slope	0.61 %
Normal Depth	0.15 ft
Discharge	2.00 cfs

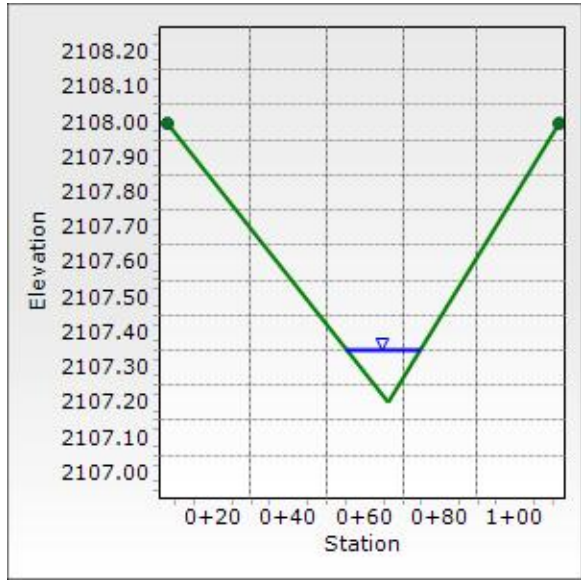

## Worksheet for ONP1

---

### Project Description

---

Friction Method	Manning Formula
Solve For	Normal Depth

---

### Input Data

---

Channel Slope	1.24 %
Discharge	1.00 cfs

---

### Section Definitions

	Station (ft)	Elevation (ft)
	0+00.00	0.36
	0+24.90	0.00
	0+36.90	0.24
	0+39.00	0.20
	0+52.30	0.47
	0+69.30	0.81

### Roughness Segment Definitions

Start Station	Ending Station	Roughness Coefficient
(0+00.00, 0.36)	(0+69.30, 0.81)	0.016

---

### Options

---

Current Roughness Weighted Method	Pavlovskii's Method
Open Channel Weighting Method	Pavlovskii's Method
Closed Channel Weighting Method	Pavlovskii's Method

---



---

### Results

---

Normal Depth	0.11 ft
Roughness Coefficient	0.016
Elevation	0.11 ft
Elevation Range	0.00 to 0.81 ft
Flow Area	0.7 ft <sup>2</sup>
Wetted Perimeter	12.75 ft
Hydraulic Radius	0.05 ft
Top Width	12.74 ft
Normal Depth	0.11 ft
Critical Depth	0.11 ft
Critical Slope	0.98 %
Velocity	1.47 ft/s
Velocity Head	0.03 ft
Specific Energy	0.14 ft
Froude Number	1.119

## Worksheet for ONP1

Results	
Flow Type	Supercritical
GVF Input Data	
Downstream Depth	0.00 ft
Length	0.00 ft
Number Of Steps	0
GVF Output Data	
Upstream Depth	0.00 ft
Profile Description	N/A
Profile Headloss	0.00 ft
Downstream Velocity	Infinity ft/s
Upstream Velocity	Infinity ft/s
Normal Depth	0.11 ft
Critical Depth	0.11 ft
Channel Slope	1.24 %
Critical Slope	0.98 %

# Cross Section for ONP1

Project Description	
Friction Method	Manning Formula
Solve For	Normal Depth

Input Data	
Channel Slope	1.24 %
Normal Depth	0.11 ft
Discharge	1.00 cfs

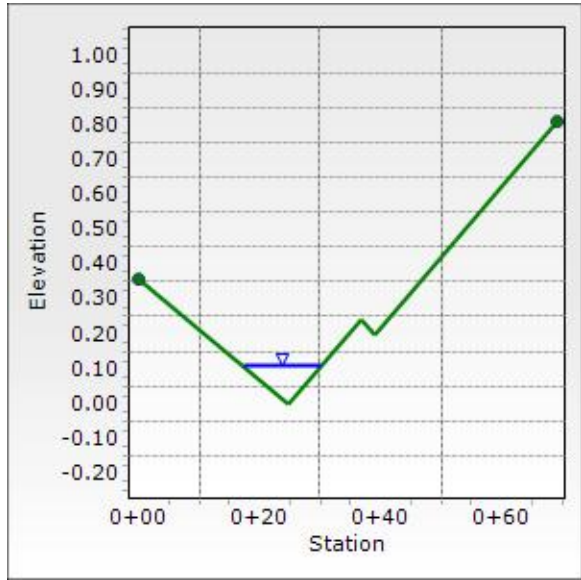

## Worksheet for ONP2 South

Project Description	
Friction Method	Manning Formula
Solve For	Normal Depth

Input Data	
Channel Slope	1.55 %
Discharge	1.00 cfs

### Section Definitions

Station (ft)	Elevation (ft)
0+00.00	0.23
0+11.30	0.00
0+11.30	4.00

### Roughness Segment Definitions

Start Station	Ending Station	Roughness Coefficient
(0+00.00, 0.23)	(0+11.30, 4.00)	0.016

Options	
Current Roughness Weighted Method	Pavlovskii's Method
Open Channel Weighting Method	Pavlovskii's Method
Closed Channel Weighting Method	Pavlovskii's Method

Results	
Normal Depth	0.14 ft
Roughness Coefficient	0.016
Elevation	0.14 ft
Elevation Range	0.00 to 4.00 ft
Flow Area	0.5 ft <sup>2</sup>
Wetted Perimeter	7.27 ft
Hydraulic Radius	0.07 ft
Top Width	7.13 ft
Normal Depth	0.14 ft
Critical Depth	0.16 ft
Critical Slope	0.89 %
Velocity	1.97 ft/s
Velocity Head	0.06 ft
Specific Energy	0.20 ft
Froude Number	1.299
Flow Type	Supercritical

GVF Input Data
----------------

## Worksheet for ONP2 South

---

### GVF Input Data

---

Downstream Depth	0.00 ft
Length	0.00 ft
Number Of Steps	0

---

### GVF Output Data

---

Upstream Depth	0.00 ft
Profile Description	N/A
Profile Headloss	0.00 ft
Downstream Velocity	Infinity ft/s
Upstream Velocity	Infinity ft/s
Normal Depth	0.14 ft
Critical Depth	0.16 ft
Channel Slope	1.55 %
Critical Slope	0.89 %

---

## Cross Section for ONP2 South

Project Description	
Friction Method	Manning Formula
Solve For	Normal Depth

Input Data	
Channel Slope	1.55 %
Normal Depth	0.14 ft
Discharge	1.00 cfs

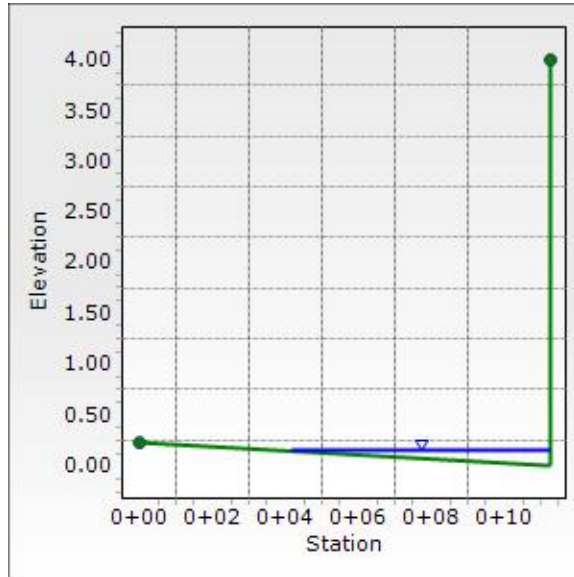

## Worksheet for ONP2 North

---

### Project Description

---

Friction Method	Manning Formula
Solve For	Normal Depth

---

### Input Data

---

Channel Slope	0.10 %
Discharge	1.00 cfs

---

### Section Definitions

Station (ft)	Elevation (ft)
0+00.00	4.00
0+00.00	0.00
0+22.00	0.26

### Roughness Segment Definitions

Start Station	Ending Station	Roughness Coefficient
(0+00.00, 4.00)	(0+22.00, 0.26)	0.016

---

### Options

---

Current Roughness Weighted Method	Pavlovskii's Method
Open Channel Weighting Method	Pavlovskii's Method
Closed Channel Weighting Method	Pavlovskii's Method

---



---

### Results

---

Normal Depth	0.20 ft
Roughness Coefficient	0.016
Elevation	0.20 ft
Elevation Range	0.00 to 4.00 ft
Flow Area	1.6 ft <sup>2</sup>
Wetted Perimeter	16.74 ft
Hydraulic Radius	0.10 ft
Top Width	16.54 ft
Normal Depth	0.20 ft
Critical Depth	0.13 ft
Critical Slope	0.95 %
Velocity	0.62 ft/s
Velocity Head	0.01 ft
Specific Energy	0.20 ft
Froude Number	0.349
Flow Type	Subcritical

---



---

### GVF Input Data

---

## Worksheet for ONP2 North

---

### GVF Input Data

---

Downstream Depth	0.00 ft
Length	0.00 ft
Number Of Steps	0

---

### GVF Output Data

---

Upstream Depth	0.00 ft
Profile Description	N/A
Profile Headloss	0.00 ft
Downstream Velocity	0.00 ft/s
Upstream Velocity	0.00 ft/s
Normal Depth	0.20 ft
Critical Depth	0.13 ft
Channel Slope	0.10 %
Critical Slope	0.95 %

---

## Cross Section for ONP2 North

Project Description	
Friction Method	Manning Formula
Solve For	Normal Depth

Input Data	
Channel Slope	0.10 %
Normal Depth	0.20 ft
Discharge	1.00 cfs

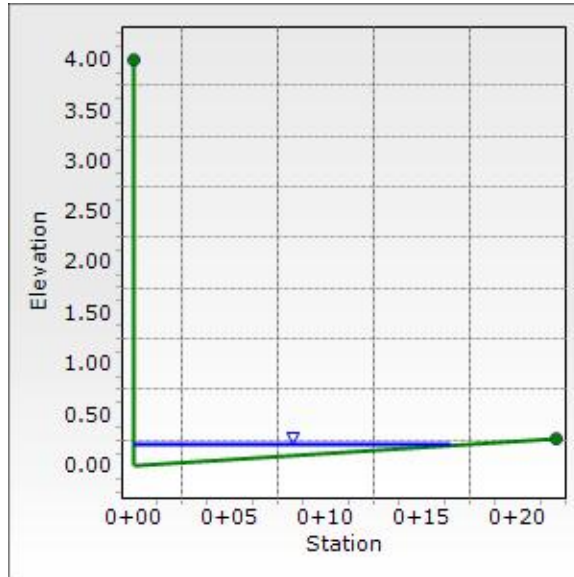

## Worksheet for ONR1

Project Description	
Friction Method	Manning Formula
Solve For	Normal Depth

---

Input Data	
Channel Slope	0.58 %
Discharge	1.00 cfs

### Section Definitions

	Station (ft)	Elevation (ft)
	0+10.58	2,111.72
	0+23.59	2,111.45
	0+35.62	2,111.30
	0+47.94	2,111.50

### Roughness Segment Definitions

Start Station	Ending Station	Roughness Coefficient
(0+10.58, 2,111.72)	(0+47.94, 2,111.50)	0.016

Options	
Current Roughness Weighted Method	Pavlovskii's Method
Open Channel Weighting Method	Pavlovskii's Method
Closed Channel Weighting Method	Pavlovskii's Method

Results	
Normal Depth	0.12 ft
Roughness Coefficient	0.016
Elevation	2,111.42 ft
Elevation Range	2,111.30 to 2,111.72 ft
Flow Area	0.9 ft <sup>2</sup>
Wetted Perimeter	16.39 ft
Hydraulic Radius	0.06 ft
Top Width	16.38 ft
Normal Depth	0.12 ft
Critical Depth	0.10 ft
Critical Slope	1.00 %
Velocity	1.06 ft/s
Velocity Head	0.02 ft
Specific Energy	0.13 ft
Froude Number	0.775
Flow Type	Subcritical

## Worksheet for ONR1

---

### GVF Input Data

---

Downstream Depth	0.00 ft
Length	0.00 ft
Number Of Steps	0

---

### GVF Output Data

---

Upstream Depth	0.00 ft
Profile Description	N/A
Profile Headloss	0.00 ft
Downstream Velocity	0.00 ft/s
Upstream Velocity	0.00 ft/s
Normal Depth	0.12 ft
Critical Depth	0.10 ft
Channel Slope	0.58 %
Critical Slope	1.00 %

---

# Cross Section for ONR1

Project Description	
Friction Method	Manning Formula
Solve For	Normal Depth

Input Data	
Channel Slope	0.58 %
Normal Depth	0.12 ft
Discharge	1.00 cfs

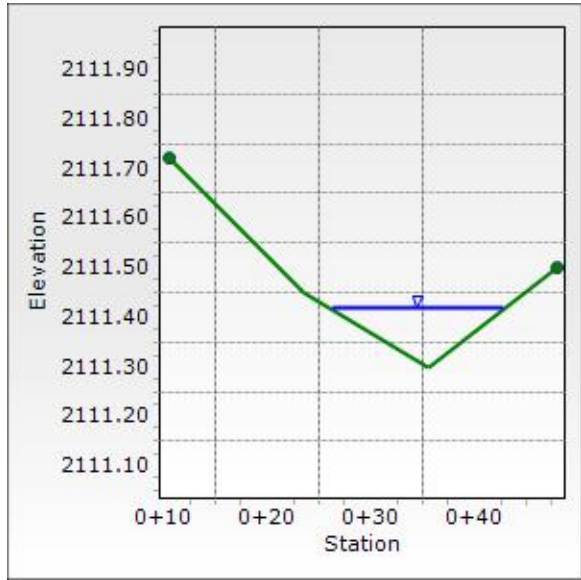

## Worksheet for ONR2

Project Description	
Friction Method	Manning Formula
Solve For	Normal Depth

Input Data	
Channel Slope	0.10 %
Discharge	0.50 cfs

### Section Definitions

Station (ft)	Elevation (ft)
0+00.00	5.48
0+21.90	0.00
0+53.30	0.63

### Roughness Segment Definitions

Start Station	Ending Station	Roughness Coefficient
(0+00.00, 5.48)	(0+53.30, 0.63)	0.016

Options	
Current Roughness Weighted Method	Pavlovskii's Method
Open Channel Weighting Method	Pavlovskii's Method
Closed Channel Weighting Method	Pavlovskii's Method

Results	
Normal Depth	0.18 ft
Roughness Coefficient	0.016
Elevation	0.18 ft
Elevation Range	0.00 to 5.48 ft
Flow Area	0.9 ft <sup>2</sup>
Wetted Perimeter	9.63 ft
Hydraulic Radius	0.09 ft
Top Width	9.60 ft
Normal Depth	0.18 ft
Critical Depth	0.12 ft
Critical Slope	0.97 %
Velocity	0.59 ft/s
Velocity Head	0.01 ft
Specific Energy	0.18 ft
Froude Number	0.346
Flow Type	Subcritical

GVF Input Data
----------------

## Worksheet for ONR2

---

### GVF Input Data

---

Downstream Depth	0.00 ft
Length	0.00 ft
Number Of Steps	0

---

### GVF Output Data

---

Upstream Depth	0.00 ft
Profile Description	N/A
Profile Headloss	0.00 ft
Downstream Velocity	0.00 ft/s
Upstream Velocity	0.00 ft/s
Normal Depth	0.18 ft
Critical Depth	0.12 ft
Channel Slope	0.10 %
Critical Slope	0.97 %

---

## Cross Section for ONR2

Project Description	
Friction Method	Manning Formula
Solve For	Normal Depth

Input Data	
Channel Slope	0.10 %
Normal Depth	0.18 ft
Discharge	0.50 cfs

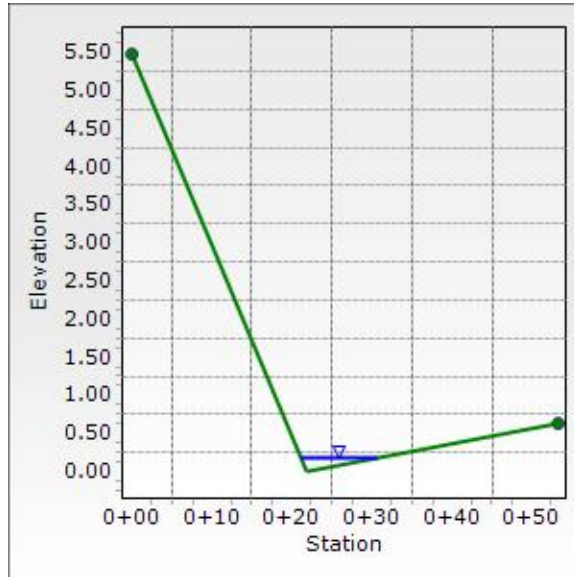

## Worksheet for SW4

Project Description	
Friction Method	Manning Formula
Solve For	Normal Depth
Input Data	
Roughness Coefficient	0.035
Channel Slope	1.11 %
Left Side Slope	4.000 H:V
Right Side Slope	4.000 H:V
Discharge	0.50 cfs
Results	
Normal Depth	0.31 ft
Flow Area	0.4 ft <sup>2</sup>
Wetted Perimeter	2.58 ft
Hydraulic Radius	0.15 ft
Top Width	2.51 ft
Critical Depth	0.25 ft
Critical Slope	3.72 %
Velocity	1.27 ft/s
Velocity Head	0.03 ft
Specific Energy	0.34 ft
Froude Number	0.567
Flow Type	Subcritical
GVF Input Data	
Downstream Depth	0.00 ft
Length	0.00 ft
Number Of Steps	0
GVF Output Data	
Upstream Depth	0.00 ft
Profile Description	N/A
Profile Headloss	0.00 ft
Downstream Velocity	0.00 ft/s
Upstream Velocity	0.00 ft/s
Normal Depth	0.31 ft
Critical Depth	0.25 ft
Channel Slope	1.11 %
Critical Slope	3.72 %

## Cross Section for SW4

Project Description	
Friction Method	Manning Formula
Solve For	Normal Depth

Input Data	
Roughness Coefficient	0.035
Channel Slope	1.11 %
Normal Depth	0.31 ft
Left Side Slope	4.000 H:V
Right Side Slope	4.000 H:V
Discharge	0.50 cfs

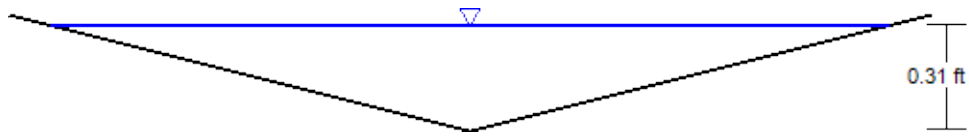

V: 1  
H: 1

## Worksheet for SW5 (MAX)

Project Description	
Friction Method	Manning Formula
Solve For	Normal Depth
Input Data	
Roughness Coefficient	0.035
Channel Slope	6.44 %
Left Side Slope	4.000 H:V
Right Side Slope	4.000 H:V
Discharge	1.00 cfs
Results	
Normal Depth	0.29 ft
Flow Area	0.3 ft <sup>2</sup>
Wetted Perimeter	2.41 ft
Hydraulic Radius	0.14 ft
Top Width	2.34 ft
Critical Depth	0.33 ft
Critical Slope	3.39 %
Velocity	2.93 ft/s
Velocity Head	0.13 ft
Specific Energy	0.43 ft
Froude Number	1.351
Flow Type	Supercritical
GVF Input Data	
Downstream Depth	0.00 ft
Length	0.00 ft
Number Of Steps	0
GVF Output Data	
Upstream Depth	0.00 ft
Profile Description	N/A
Profile Headloss	0.00 ft
Downstream Velocity	Infinity ft/s
Upstream Velocity	Infinity ft/s
Normal Depth	0.29 ft
Critical Depth	0.33 ft
Channel Slope	6.44 %
Critical Slope	3.39 %

# Cross Section for SW5 (MAX)

Project Description	
Friction Method	Manning Formula
Solve For	Normal Depth
Input Data	
Roughness Coefficient	0.035
Channel Slope	6.44 %
Normal Depth	0.29 ft
Left Side Slope	4.000 H:V
Right Side Slope	4.000 H:V
Discharge	1.00 cfs

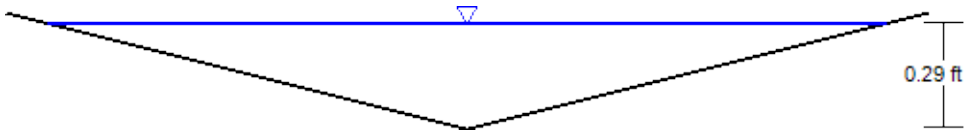

V: 1 H: 1

## Worksheet for SW5 (MIN)

Project Description	
Friction Method	Manning
	Formula
Solve For	Normal Depth
Input Data	
Roughness Coefficient	0.035
Channel Slope	2.61 %
Left Side Slope	4.000 H:V
Right Side Slope	4.000 H:V
Discharge	1.00 cfs
Results	
Normal Depth	0.35 ft
Flow Area	0.5 ft <sup>2</sup>
Wetted Perimeter	2.85 ft
Hydraulic Radius	0.17 ft
Top Width	2.77 ft
Critical Depth	0.33 ft
Critical Slope	3.39 %
Velocity	2.09 ft/s
Velocity Head	0.07 ft
Specific Energy	0.41 ft
Froude Number	0.884
Flow Type	Subcritical
GVF Input Data	
Downstream Depth	0.00 ft
Length	0.00 ft
Number Of Steps	0
GVF Output Data	
Upstream Depth	0.00 ft
Profile Description	N/A
Profile Headloss	0.00 ft
Downstream Velocity	Infinity ft/s
Upstream Velocity	Infinity ft/s
Normal Depth	0.35 ft
Critical Depth	0.33 ft
Channel Slope	2.61 %
Critical Slope	3.39 %

## Cross Section for SW5 (MIN)

Project Description	
Friction Method	Manning Formula
Solve For	Normal Depth

Input Data	
Roughness Coefficient	0.035
Channel Slope	2.61 %
Normal Depth	0.35 ft
Left Side Slope	4.000 H:V
Right Side Slope	4.000 H:V
Discharge	1.00 cfs

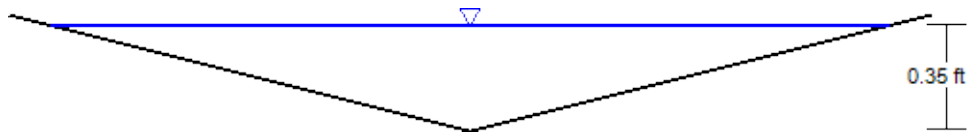

V: 1  
H: 1

## Worksheet for Typ Block Wall 4' Bottom Width

Project Description	
Friction Method	Manning Formula
Solve For	Normal Depth
Input Data	
Roughness Coefficient	0.013
Channel Slope	0.50 %
Bottom Width	4.00 ft
Discharge	1.00 cfs
Results	
Normal Depth	0.13 ft
Flow Area	0.5 ft <sup>2</sup>
Wetted Perimeter	4.25 ft
Hydraulic Radius	0.12 ft
Top Width	4.00 ft
Critical Depth	0.12 ft
Critical Slope	0.53 %
Velocity	1.96 ft/s
Velocity Head	0.06 ft
Specific Energy	0.19 ft
Froude Number	0.971
Flow Type	Subcritical
GVF Input Data	
Downstream Depth	0.00 ft
Length	0.00 ft
Number Of Steps	0
GVF Output Data	
Upstream Depth	0.00 ft
Profile Description	N/A
Profile Headloss	0.00 ft
Downstream Velocity	0.00 ft/s
Upstream Velocity	0.00 ft/s
Normal Depth	0.13 ft
Critical Depth	0.12 ft
Channel Slope	0.50 %
Critical Slope	0.53 %

# Cross Section for Typ Block Wall 4' Bottom Width

Project Description	
Friction Method	Manning Formula
Solve For	Normal Depth
Input Data	
Roughness Coefficient	0.013
Channel Slope	0.50 %
Normal Depth	0.13 ft
Bottom Width	4.00 ft
Discharge	1.00 cfs

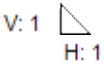
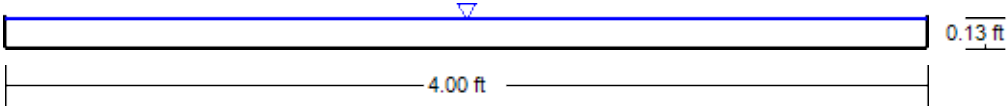

## Worksheet for ONH Emergency Overflow (ONH + ONP)

---

### Project Description

---

Friction Method	Manning Formula
Solve For	Normal Depth

---

### Input Data

---

Channel Slope	0.61 %
Discharge	3.00 cfs

---

### Section Definitions

Station (ft)	Elevation (ft)
0+07.98	2,108.00
0+66.03	2,107.20
1+11.28	2,108.00

### Roughness Segment Definitions

Start Station	Ending Station	Roughness Coefficient
(0+07.98, 2,108.00)	(1+11.28, 2,108.00)	0.016

---

### Options

---

Current Roughness Weighted Method	Pavlovskii's Method
Open Channel Weighting Method	Pavlovskii's Method
Closed Channel Weighting Method	Pavlovskii's Method

---



---

### Results

---

Normal Depth	0.18 ft
Roughness Coefficient	0.016
Elevation	2,107.38 ft
Elevation Range	2,107.20 to 2,108.00 ft
Flow Area	2.1 ft <sup>2</sup>
Wetted Perimeter	23.11 ft
Hydraulic Radius	0.09 ft
Top Width	23.11 ft
Normal Depth	0.18 ft
Critical Depth	0.17 ft
Critical Slope	0.85 %
Velocity	1.45 ft/s
Velocity Head	0.03 ft
Specific Energy	0.21 ft
Froude Number	0.855
Flow Type	Subcritical

---



---

### GVF Input Data

---

## Worksheet for ONH Emergency Overflow (ONH + ONP)

---

### GVF Input Data

---

Downstream Depth	0.00 ft
Length	0.00 ft
Number Of Steps	0

---

### GVF Output Data

---

Upstream Depth	0.00 ft
Profile Description	N/A
Profile Headloss	0.00 ft
Downstream Velocity	0.00 ft/s
Upstream Velocity	0.00 ft/s
Normal Depth	0.18 ft
Critical Depth	0.17 ft
Channel Slope	0.61 %
Critical Slope	0.85 %

---

## Cross Section for ONH Emergency Overflow (ONH + ONP)

Project Description	
Friction Method	Manning Formula
Solve For	Normal Depth

  

Input Data	
Channel Slope	0.61 %
Normal Depth	0.18 ft
Discharge	3.00 cfs

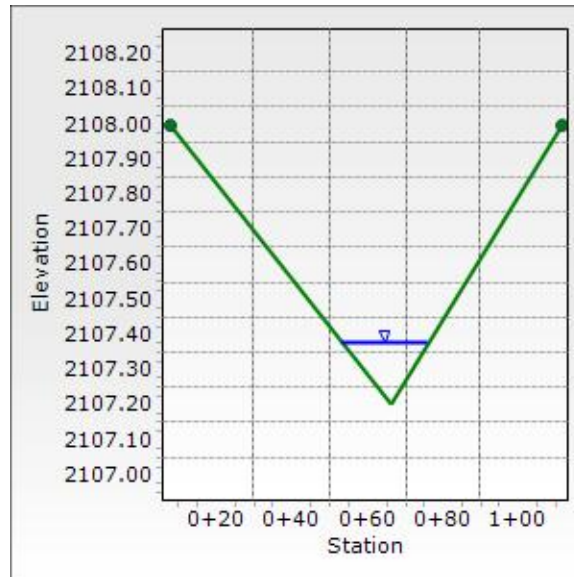

# HYDROLOGIC CRITERIA AND DRAINAGE DESIGN MANUAL

## NOMOGRAPH - INLET CONTROL RCP

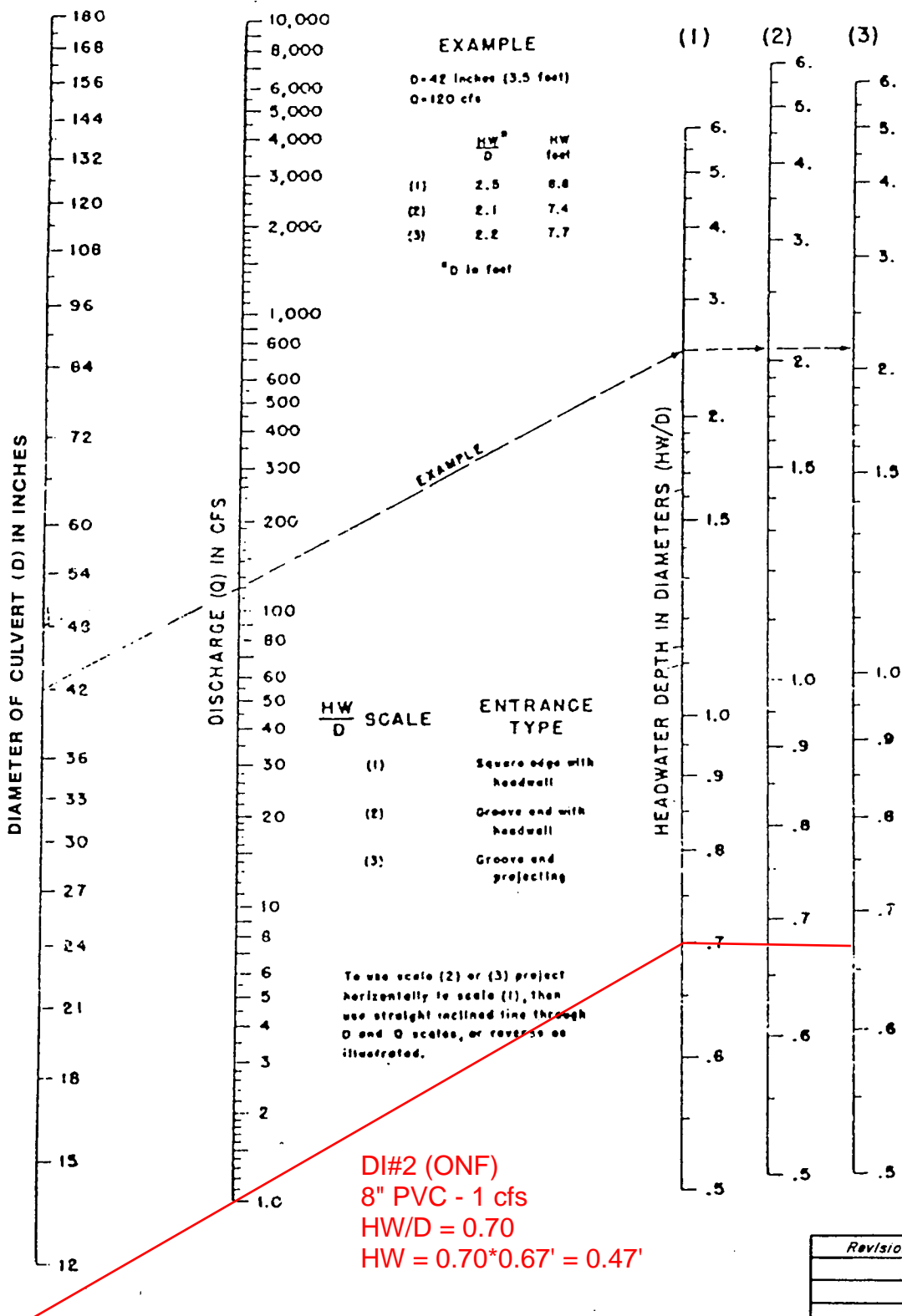

Revision	Date

## NOMOGRAPH - INLET CONTROL RCP

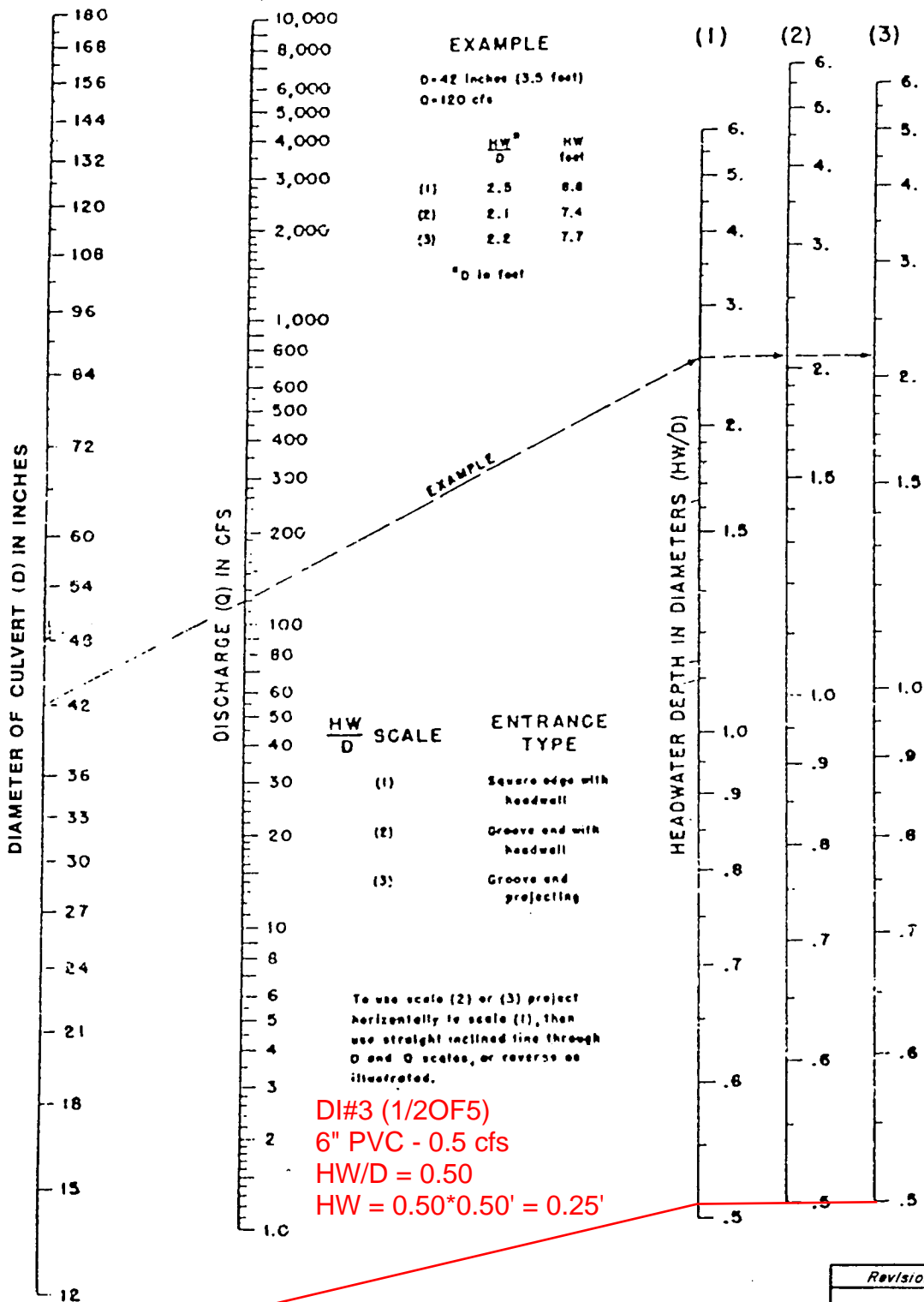

Revision	Date

## 6", 8", and 10" Pipe Diameter Rating Table

Project Description						
Friction Method	Manning Formula					
Solve For	Full Flow Capacity					
Input Data						
Roughness Coefficient	0.010					
Channel Slope	0.50 %					
Normal Depth	0.50 ft					
Diameter	6.0 in					
Discharge	0.52 cfs					
Diameter (in)	Normal Depth (ft)	Discharge (cfs)	Velocity (ft/s)	Flow Area (ft <sup>2</sup> )	Wetted Perimeter (ft)	Top Width (ft)
6.0	0.50	0.52	2.63	0.2	1.57	0.00
8.0	0.67	1.11	3.18	0.3	2.09	0.00
10.0	0.83	2.01	3.69	0.5	2.62	0.00

HEC-RAS HEC-RAS 5.0.7 March 2019  
 U. S. Army Corps of Engineers  
 Hydrologic Engineering Center  
 609 Second Street  
 Davis, California

```

X   X   XXXXXX   XXXX   XXXX   XX   XXXX
X   X   X       X   X   X   X   X   X   X
X   X   X       X       X   X   X   X   X
XXXXXXXX XXXX   X       XXX XXXX   XXXXXX   XXXX
X   X   X       X       X   X   X   X   X
X   X   X       X   X   X   X   X   X   X
X   X   XXXXXX   XXXX   X   X   X   X   XXXXX
    
```

PROJECT DATA

Project Title: Sirius Avenue  
 Project File : SiriusAvenue.prj  
 Run Date and Time: 1/23/2024 7:13:39 PM

Project in English units

PLAN DATA

Plan Title: Proposed Conditions\_District2\_UP\_2024  
 Plan File : k:\LAV\_Civil\092965012 - Area 15 District 2 (Fisher Brothers)\Reports\DRAINAGE\05\_UP\Culculations\Hydraulics\HECRAS\SiriusAvenue.p05

Geometry Title: Proposed Conditions\_Geom\_District2\_UP  
 Geometry File : k:\LAV\_Civil\092965012 - Area 15 District 2 (Fisher Brothers)\Reports\DRAINAGE\05\_UP\Culculations\Hydraulics\HECRAS\SiriusAvenue.g02

Flow Title : Sirius\_EventLots  
 Flow File : k:\LAV\_Civil\092965012 - Area 15 District 2 (Fisher Brothers)\Reports\DRAINAGE\05\_UP\Culculations\Hydraulics\HECRAS\SiriusAvenue.f02

Plan Summary Information:

Number of: Cross Sections = 6 Multiple Openings = 0  
 Culverts = 0 Inline Structures = 0  
 Bridges = 0 Lateral Structures = 2

Computational Information

Water surface calculation tolerance = 0.01  
 Critical depth calculation tolerance = 0.01  
 Maximum number of iterations = 20  
 Maximum difference tolerance = 0.3  
 Flow tolerance factor = 0.001

Computation Options

Critical depth computed at all cross sections  
 Conveyance Calculation Method: At breaks in n values only  
 Friction Slope Method: Program Selects Appropriate method  
 Computational Flow Regime: Supercritical Flow

FLOW DATA

Flow Title: Sirius\_EventLots  
 Flow File : k:\LAV\_Civil\092965012 - Area 15 District 2 (Fisher Brothers)\Reports\DRAINAGE\05\_UP\Culculations\Hydraulics\HECRAS\SiriusAvenue.f02

Flow Data (cfs)

River	Reach	RS	100-yr
SIRIUS AVE	SIRIUS	1916	1158
SIRIUS AVE	SIRIUS	1215	1158
SIRIUS AVE	SIRIUS	1036	1158

Boundary Conditions

River	Reach	Profile	Upstream	Downstream
SIRIUS AVE	SIRIUS	100-yr	Critical	Critical

GEOMETRY DATA

Geometry Title: Proposed Conditions\_Geom\_District2\_UP  
 Geometry File : k:\LAV\_Civil\092965012 - Area 15 District 2 (Fisher Brothers)\Reports\DRAINAGE\05\_UP\Culculations\Hydraulics\HECRAS\SiriusAvenue.g02

CROSS SECTION

RIVER: SIRIUS AVE  
 REACH: SIRIUS RS: 1916

INPUT

Description:

Station		Elevation		Data		num=		42	
Sta	Elev	Sta	Elev	Sta	Elev	Sta	Elev	Sta	Elev
0	2124	45.66	2124	47.74	2123.09	50.09	2122	52.26	2121.54
58.04	2121.25	58.1	2120.75	59.6	2120.86	82.6	2121	105.6	2120.81
107.1	2120.7	107.1	2121.2	112.1	2121.2	115.24	2121.48	115.44	2121.47
116.39	2121.5	117.08	2121.52	124.01	2121.77	127.89	2121.9	128.11	2121.92
128.26	2121.93	216.93	2122	219.4	2121.94	219.67	2121.94	226.29	2121.76
229.79	2121.74	234.52	2121.87	234.72	2121.86	236.6	2121.87	236.67	2121.87
240.82	2122	339.66	2122.04	339.8	2122.02	339.82	2122.02	343.87	2122.35
344.04	2122.35	348.23	2122.68	350.49	2122.83	357.66	2122.9	363.61	2123.1
364.9	2123.14	365.91	2123.19						

Manning's n		Values		num=		6			
Sta	n Val	Sta	n Val	Sta	n Val	Sta	n Val		
0	.016	58.04	.013	59.6	.016	105.6	.013	112.1	.025
339.82	.016								

Bank Sta:	Left	Right	Lengths:	Left Channel	Right	Coeff	Contr.	Expan.
0	365.91		166.86	166.86	166.86		.1	.3

CROSS SECTION

RIVER: SIRIUS AVE  
 REACH: SIRIUS RS: 1750

INPUT

Description:

Station		Elevation		Data		num=		14	
Sta	Elev	Sta	Elev	Sta	Elev	Sta	Elev	Sta	Elev
0	2120.4	0	2118	53	2117	53	2116.5	54.5	2116.61
77.5	2117.2	90.5	2116.66	92	2116.55	92	2117.05	97	2117.58
97	2120	97.5	2120	97.5	2117.58	100.5	2117.6		

Manning's n		Values		num=		5			
Sta	n Val	Sta	n Val	Sta	n Val	Sta	n Val		
0	.016	53	.013	54.5	.016	90.5	.013	97.5	.02

Bank Sta:	Left	Right	Lengths:	Left Channel	Right	Coeff	Contr.	Expan.
53	92		216.84	216.84	216.84		.1	.3

Right Levee Station= 97 Elevation= 2120

CROSS SECTION

RIVER: SIRIUS AVE  
 REACH: SIRIUS RS: 1533

INPUT

Description:

Station		Elevation		Data		num=		19	
Sta	Elev	Sta	Elev	Sta	Elev	Sta	Elev	Sta	Elev
0	2114.3	0	2112	17	2111.7	34	2112	59	2113.2
59	2116	59	2120.5	59.5	2120.5	59.5	2116	59.5	2113.2
65.5	2112.5	65.5	2112	67	2112.11	90	2112.67	113	2112.11
118	2112.58	118	2113.08	124	2113	150	2114		

Manning's n		Values		num=		7			
Sta	n Val	Sta	n Val	Sta	n Val	Sta	n Val		
0	.016	59	.02	59.5	.016	65.5	.013	67	.016
113	.013	124	.02						

Bank Sta:	Left	Right	Lengths:	Left Channel	Right	Coeff	Contr.	Expan.
65.5	118		318.07	318.07	318.07		.1	.3

Ineffective Flow num= 1  
 Sta L Sta R Elev Permanent  
 124 150 2115.42 F  
 Left Levee Station= 59.5 Elevation= 2116

LATERAL STRUCTURE

RIVER: SIRIUS AVE  
 REACH: SIRIUS RS: 1245

INPUT

Description:

Lateral structure position = Left overbank

Distance from Upstream XS =	
Deck/Roadway Width =	10
Weir Coefficient =	3
Weir Flow Reference =	Water Surface
Weir Embankment Coordinates num =	3
Sta Elev Sta Elev Sta Elev	
0 2109.8 30 2110.3 60 2109.9	

Weir crest shape = Broad Crested

CROSS SECTION

RIVER: SIRIUS AVE  
 REACH: SIRIUS RS: 1215

INPUT

Description:

Station		Elevation		Data		num=		15	
Sta	Elev	Sta	Elev	Sta	Elev	Sta	Elev	Sta	Elev
0	2110.3	93	2110	119	2109.5	123	2109.25	127	2109.5
150	2110	173	2109.8	174.5	2109.69	174.5	2110.11	179.5	2110.19
184.5	2110.26	184.5	2112.68	185	2112.68	185	2110.26	203	2111

Manning's n		Values		num=		6	
Sta	n Val	Sta	n Val	Sta	n Val	Sta	n Val
0	.016	119	.013	127	.016	173	.013
184.5	.015					179.5	.02

Bank	Sta	Left	Right	Lengths:	Left	Channel	Right	Coeff	Contr.	Expan.
	119		174.5		45	45	45		.1	.3
Right Levee	Station=	184.5		Elevation=	2112.68					

LATERAL STRUCTURE

RIVER: SIRIUS AVE  
 REACH: SIRIUS RS: 1177

INPUT

Description:

Lateral structure position = Left overbank

Distance from Upstream XS =

Deck/Roadway Width = 1

Weir Coefficient = 3

Weir Flow Reference = Water Surface

Weir Embankment Coordinates num = 2

Sta	Elev	Sta	Elev
0	2111.06	14	2110.95

Weir crest shape = Broad Crested

CROSS SECTION

RIVER: SIRIUS AVE  
 REACH: SIRIUS RS: 1170

INPUT

Description:

Station		Elevation		Data		num=		16	
Sta	Elev	Sta	Elev	Sta	Elev	Sta	Elev	Sta	Elev
137.43	2110.95	147.47	2110.85	174.27	2109.7	194.86	2109.5	200.12	2109.4
200.12	2108.9	202.12	2109.07	226.85	2109.5	250.35	2109.1	252.35	2108.93
252.35	2109.43	263.75	2109.53	263.75	2111.95	264.89	2111.95	264.89	2109.53
284.54	2111								

Manning's n		Values		num=		2	
Sta	n Val	Sta	n Val	Sta	n Val	Sta	n Val
137.43	.016	263.75	.013				

Bank	Sta	Left	Right	Lengths:	Left	Channel	Right	Coeff	Contr.	Expan.
	137.43		252.35		134	134	134		.1	.3
Right Levee	Station=	263.75		Elevation=	2111.95					

CROSS SECTION

RIVER: SIRIUS AVE  
 REACH: SIRIUS RS: 1036

INPUT

Description:

Station		Elevation		Data		num=		15	
Sta	Elev	Sta	Elev	Sta	Elev	Sta	Elev	Sta	Elev
221.4	2111.22	222.4	2111.22	222.4	2108.7	227.4	2108.6	232.4	2108.5
232.4	2108	233.9	2108.17	256.9	2108.3	281.9	2108.17	283.9	2108
283.9	2108.5	288.9	2108.6	293.9	2108.7	293.9	2111.22	294.9	2111.22

Manning's n		Values		num=		3	
Sta	n Val	Sta	n Val	Sta	n Val	Sta	n Val
221.4	.013	222.4	.016	293.9	.013		

Bank	Sta	Left	Right	Lengths:	Left	Channel	Right	Coeff	Contr.	Expan.
	222.4		283.9		0	0	0		.1	.3

SUMMARY OF MANNING'S N VALUES

River: SIRIUS AVE

Reach	River Sta.	n1	n2	n3	n4	n5	n6	n7
SIRIUS	1916	.016	.013	.016	.013	.025	.016	
SIRIUS	1750	.016	.013	.016	.013	.02		
SIRIUS	1533	.016	.02	.016	.013	.016	.013	.02
SIRIUS	1245	Lat Struct						
SIRIUS	1215	.016	.013	.016	.013	.02	.015	
SIRIUS	1177	Lat Struct						
SIRIUS	1170	.016	.013					
SIRIUS	1036	.013	.016	.013				

SUMMARY OF REACH LENGTHS

River: SIRIUS AVE

Reach	River Sta.	Left	Channel	Right
SIRIUS	1916	166.86	166.86	166.86
SIRIUS	1750	216.84	216.84	216.84
SIRIUS	1533	318.07	318.07	318.07
SIRIUS	1245	Lat Struct		
SIRIUS	1215	45	45	45
SIRIUS	1177	Lat Struct		
SIRIUS	1170	134	134	134
SIRIUS	1036	0	0	0

SUMMARY OF CONTRACTION AND EXPANSION COEFFICIENTS

River: SIRIUS AVE

Reach	River Sta.	Contr.	Expan.
SIRIUS	1916	.1	.3
SIRIUS	1750	.1	.3
SIRIUS	1533	.1	.3
SIRIUS	1245	Lat Struct	
SIRIUS	1215	.1	.3
SIRIUS	1177	Lat Struct	
SIRIUS	1170	.1	.3
SIRIUS	1036	.1	.3

HEC-RAS Plan: PROP2UP\_2024 River: SIRIUS AVE Reach: SIRIUS Profile: 100-yr

Reach	River Sta	Profile	Q Total (cfs)	Min Ch El (ft)	W.S. Elev (ft)	Crit W.S. (ft)	E.G. Elev (ft)	E.G. Slope (ft/ft)	Vel Chnl (ft/s)	Flow Area (sq ft)	Top Width (ft)	Froude # Chl
SIRIUS	1916	100-yr	1158.00	2120.70	2122.55	2122.55	2122.93	0.008145	4.96	233.59	297.67	0.99
SIRIUS	1750	100-yr	1158.00	2116.50	2118.23	2118.93	2120.74	0.015487	14.09	95.80	97.00	2.14
SIRIUS	1533	100-yr	1158.00	2112.00	2113.71	2114.66	2117.09	0.017377	15.05	79.46	83.06	2.29
SIRIUS	1245		Lat Struct									
SIRIUS	1215	100-yr	1095.45	2109.25	2110.68	2111.04	2111.89	0.011741	10.27	129.87	184.50	1.88
SIRIUS	1177		Lat Struct									
SIRIUS	1170	100-yr	1044.38	2108.90	2110.98	2110.98	2111.62	0.003480	6.38	162.97	126.32	1.00
SIRIUS	1036	100-yr	1044.38	2108.00	2110.22	2110.22	2111.16	0.003169	7.89	135.03	71.50	1.00

Plan: PROP2UP\_2024 SIRIUS AVE SIRIUS RS: 1916 Profile: 100-yr

E.G. Elev (ft)	2122.93	Element	Left OB	Channel	Right OB
Vel Head (ft)	0.38	Wt. n-Val.		0.023	
W.S. Elev (ft)	2122.55	Reach Len. (ft)	166.86	166.86	166.86
Crit W.S. (ft)	2122.55	Flow Area (sq ft)		233.59	
E.G. Slope (ft/ft)	0.008145	Area (sq ft)		233.59	
Q Total (cfs)	1158.00	Flow (cfs)		1158.00	
Top Width (ft)	297.67	Top Width (ft)		297.67	
Vel Total (ft/s)	4.96	Avg. Vel. (ft/s)		4.96	
Max Chl Dpth (ft)	1.85	Hydr. Depth (ft)		0.78	
Conv. Total (cfs)	12831.4	Conv. (cfs)		12831.4	
Length Wtd. (ft)	166.86	Wetted Per. (ft)		298.85	
Min Ch El (ft)	2120.70	Shear (lb/sq ft)		0.40	
Alpha	1.00	Stream Power (lb/ft s)		1.97	
Frctn Loss (ft)	1.97	Cum Volume (acre-ft)	0.51	1.81	0.17
C & E Loss (ft)	0.21	Cum SA (acres)	0.77	1.63	0.25

Plan: PROP2UP\_2024 SIRIUS AVE SIRIUS RS: 1750 Profile: 100-yr

E.G. Elev (ft)	2120.74	Element	Left OB	Channel	Right OB
Vel Head (ft)	2.51	Wt. n-Val.	0.016	0.016	0.013
W.S. Elev (ft)	2118.23	Reach Len. (ft)	216.84	216.84	216.84
Crit W.S. (ft)	2118.93	Flow Area (sq ft)	38.81	52.41	4.59
E.G. Slope (ft/ft)	0.015487	Area (sq ft)	38.81	52.41	4.59
Q Total (cfs)	1158.00	Flow (cfs)	363.23	738.22	56.55
Top Width (ft)	97.00	Top Width (ft)	53.00	39.00	5.00
Vel Total (ft/s)	12.09	Avg. Vel. (ft/s)	9.36	14.09	12.33
Max Chl Dpth (ft)	1.73	Hydr. Depth (ft)	0.73	1.34	0.92
Conv. Total (cfs)	9305.1	Conv. (cfs)	2918.7	5932.0	454.4
Length Wtd. (ft)	216.84	Wetted Per. (ft)	53.24	40.03	5.68
Min Ch El (ft)	2116.50	Shear (lb/sq ft)	0.70	1.27	0.78
Alpha	1.10	Stream Power (lb/ft s)	6.60	17.83	9.63
Frctn Loss (ft)	3.56	Cum Volume (acre-ft)	0.44	1.26	0.16
C & E Loss (ft)	0.09	Cum SA (acres)	0.66	0.98	0.24

Plan: PROP2UP\_2024 SIRIUS AVE SIRIUS RS: 1533 Profile: 100-yr

E.G. Elev (ft)	2117.09	Element	Left OB	Channel	Right OB
Vel Head (ft)	3.38	Wt. n-Val.	0.016	0.016	0.013
W.S. Elev (ft)	2113.71	Reach Len. (ft)	318.07	318.07	318.07
Crit W.S. (ft)	2114.66	Flow Area (sq ft)	5.18	70.23	4.04
E.G. Slope (ft/ft)	0.017377	Area (sq ft)	5.18	70.23	10.67
Q Total (cfs)	1158.00	Flow (cfs)	54.26	1056.92	46.82
Top Width (ft)	83.06	Top Width (ft)	6.00	52.50	24.56
Vel Total (ft/s)	14.57	Avg. Vel. (ft/s)	10.47	15.05	11.58
Max Chl Dpth (ft)	2.01	Hydr. Depth (ft)	0.86	1.34	0.67
Conv. Total (cfs)	8784.7	Conv. (cfs)	411.7	8017.8	355.2
Length Wtd. (ft)	318.07	Wetted Per. (ft)	6.55	53.54	6.00
Min Ch El (ft)	2112.00	Shear (lb/sq ft)	0.86	1.42	0.73
Alpha	1.02	Stream Power (lb/ft s)	8.98	21.42	8.46
Frctn Loss (ft)	4.54	Cum Volume (acre-ft)	0.33	0.95	0.12
C & E Loss (ft)	0.65	Cum SA (acres)	0.52	0.75	0.17

Plan: PROP2UP\_2024 SIRIUS AVE SIRIUS RS: 1215 Profile: 100-yr

E.G. Elev (ft)	2111.89	Element	Left OB	Channel	Right OB
Vel Head (ft)	1.21	Wt. n-Val.	0.016	0.015	0.015
W.S. Elev (ft)	2110.68	Reach Len. (ft)	45.00	45.00	45.00
Crit W.S. (ft)	2111.04	Flow Area (sq ft)	73.66	51.26	4.94
E.G. Slope (ft/ft)	0.011741	Area (sq ft)	73.66	51.26	4.94
Q Total (cfs)	1095.45	Flow (cfs)	537.25	526.27	31.93
Top Width (ft)	184.50	Top Width (ft)	119.00	55.50	10.00
Vel Total (ft/s)	8.44	Avg. Vel. (ft/s)	7.29	10.27	6.46
Max Chl Dpth (ft)	1.43	Hydr. Depth (ft)	0.62	0.92	0.49
Conv. Total (cfs)	10109.7	Conv. (cfs)	4958.2	4856.9	294.7
Length Wtd. (ft)		Wetted Per. (ft)	119.39	55.95	10.42
Min Ch El (ft)	2109.25	Shear (lb/sq ft)	0.45	0.67	0.35
Alpha	1.10	Stream Power (lb/ft s)	3.30	6.90	2.25
Frctn Loss (ft)		Cum Volume (acre-ft)	0.04	0.51	0.06
C & E Loss (ft)		Cum SA (acres)	0.06	0.36	0.04

Plan: PROP2UP\_2024 SIRIUS AVE SIRIUS RS: 1170 Profile: 100-yr

E.G. Elev (ft)	2111.62	Element	Left OB	Channel	Right OB
Vel Head (ft)	0.64	Wt. n-Val.		0.016	0.016
W.S. Elev (ft)	2110.98	Reach Len. (ft)	134.00	134.00	134.00
Crit W.S. (ft)	2110.98	Flow Area (sq ft)		145.84	17.14
E.G. Slope (ft/ft)	0.003480	Area (sq ft)		145.84	17.14
Q Total (cfs)	1044.38	Flow (cfs)		930.66	113.72
Top Width (ft)	126.32	Top Width (ft)		114.92	11.40
Vel Total (ft/s)	6.41	Avg. Vel. (ft/s)		6.38	6.64
Max Chl Dpth (ft)	2.08	Hydr. Depth (ft)		1.27	1.50
Conv. Total (cfs)	17704.3	Conv. (cfs)		15776.5	1927.7
Length Wtd. (ft)	134.00	Wetted Per. (ft)		116.00	12.85
Min Ch El (ft)	2108.90	Shear (lb/sq ft)		0.27	0.29
Alpha	1.00	Stream Power (lb/ft s)		1.74	1.92
Frctn Loss (ft)	0.44	Cum Volume (acre-ft)		0.41	0.05
C & E Loss (ft)	0.03	Cum SA (acres)		0.27	0.03

Plan: PROP2UP\_2024 SIRIUS AVE SIRIUS RS: 1036 Profile: 100-yr

E.G. Elev (ft)	2111.16	Element	Left OB	Channel	Right OB
Vel Head (ft)	0.94	Wt. n-Val.		0.016	0.016
W.S. Elev (ft)	2110.22	Reach Len. (ft)			
Crit W.S. (ft)	2110.22	Flow Area (sq ft)		118.85	16.18
E.G. Slope (ft/ft)	0.003169	Area (sq ft)		118.85	16.18
Q Total (cfs)	1044.38	Flow (cfs)		938.28	106.11
Top Width (ft)	71.50	Top Width (ft)		61.50	10.00
Vel Total (ft/s)	7.73	Avg. Vel. (ft/s)		7.89	6.56
Max Chl Dpth (ft)	2.22	Hydr. Depth (ft)		1.93	1.62
Conv. Total (cfs)	18553.3	Conv. (cfs)		16668.4	1884.9
Length Wtd. (ft)		Wetted Per. (ft)		64.04	11.52
Min Ch El (ft)	2108.00	Shear (lb/sq ft)		0.37	0.28
Alpha	1.01	Stream Power (lb/ft s)		2.90	1.82
Frctn Loss (ft)		Cum Volume (acre-ft)			
C & E Loss (ft)		Cum SA (acres)			

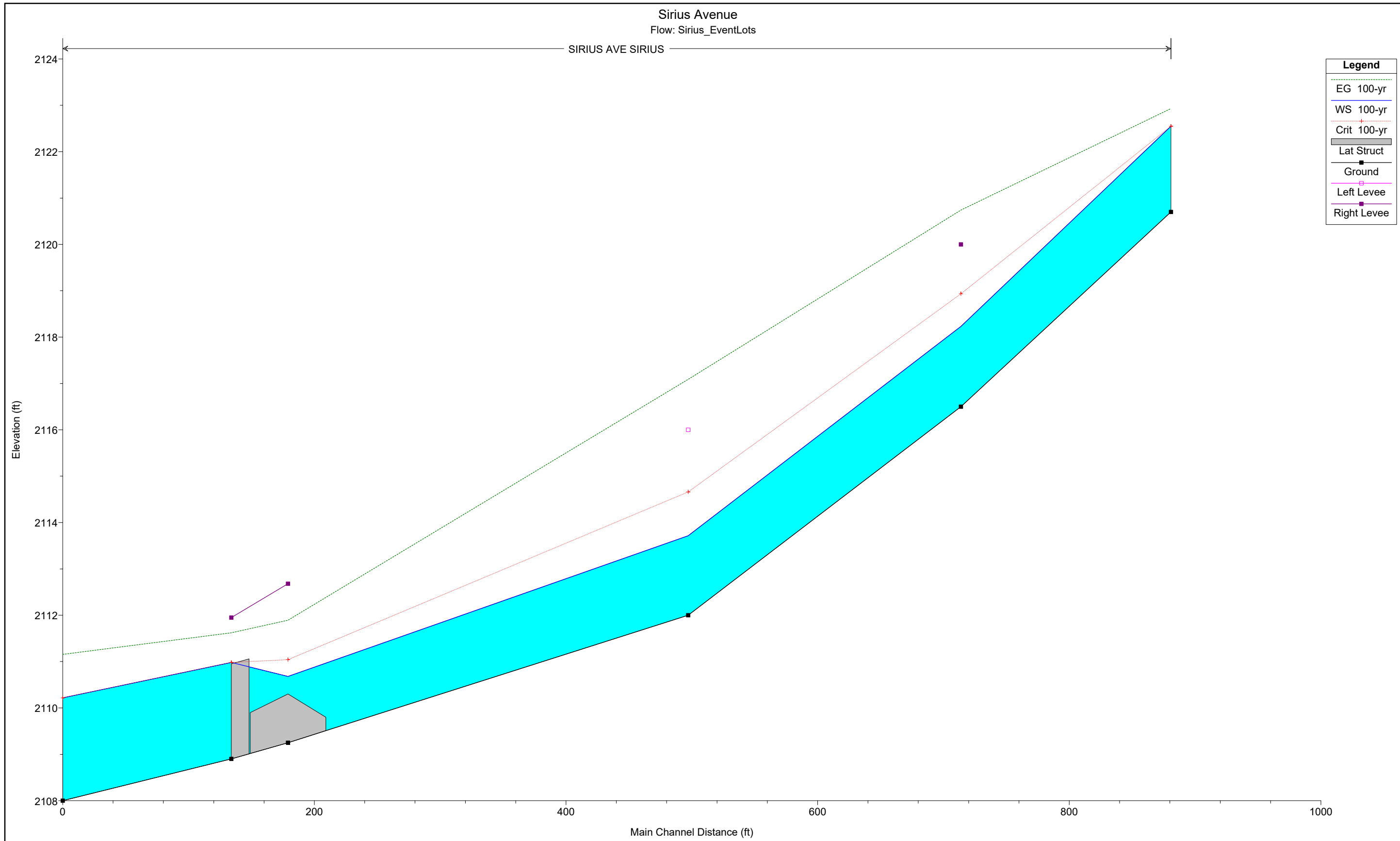

Sirius Avenue  
Flow: Sirius\_EventLots

**Legend**

- WS 100-yr
- Ground
- Bank Sta
- Levee
- Ineff

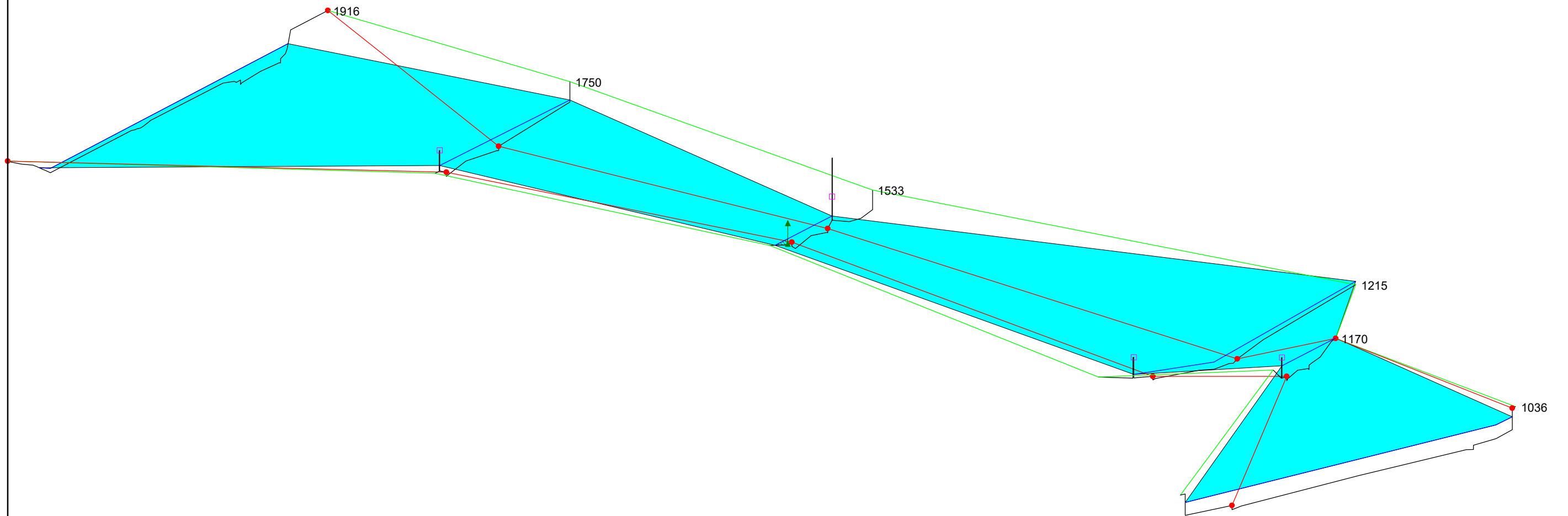

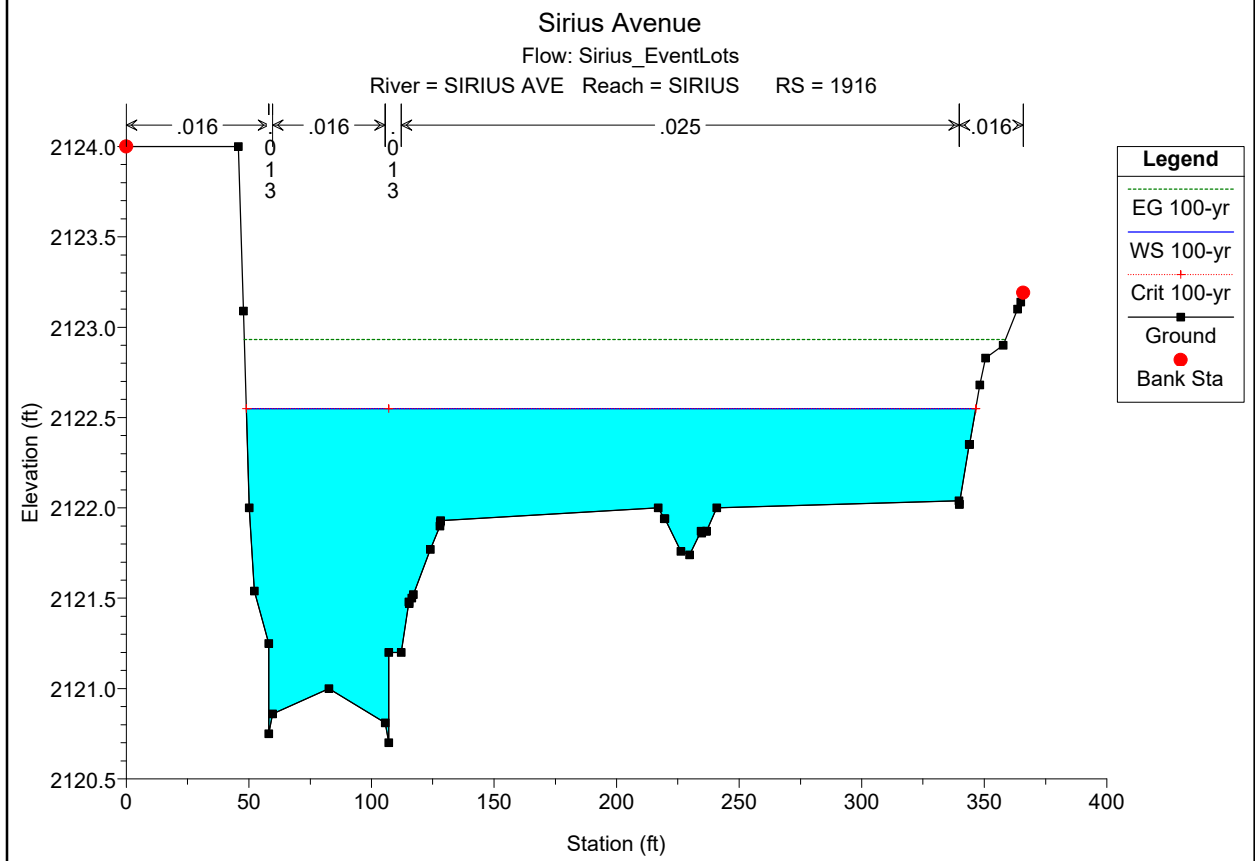
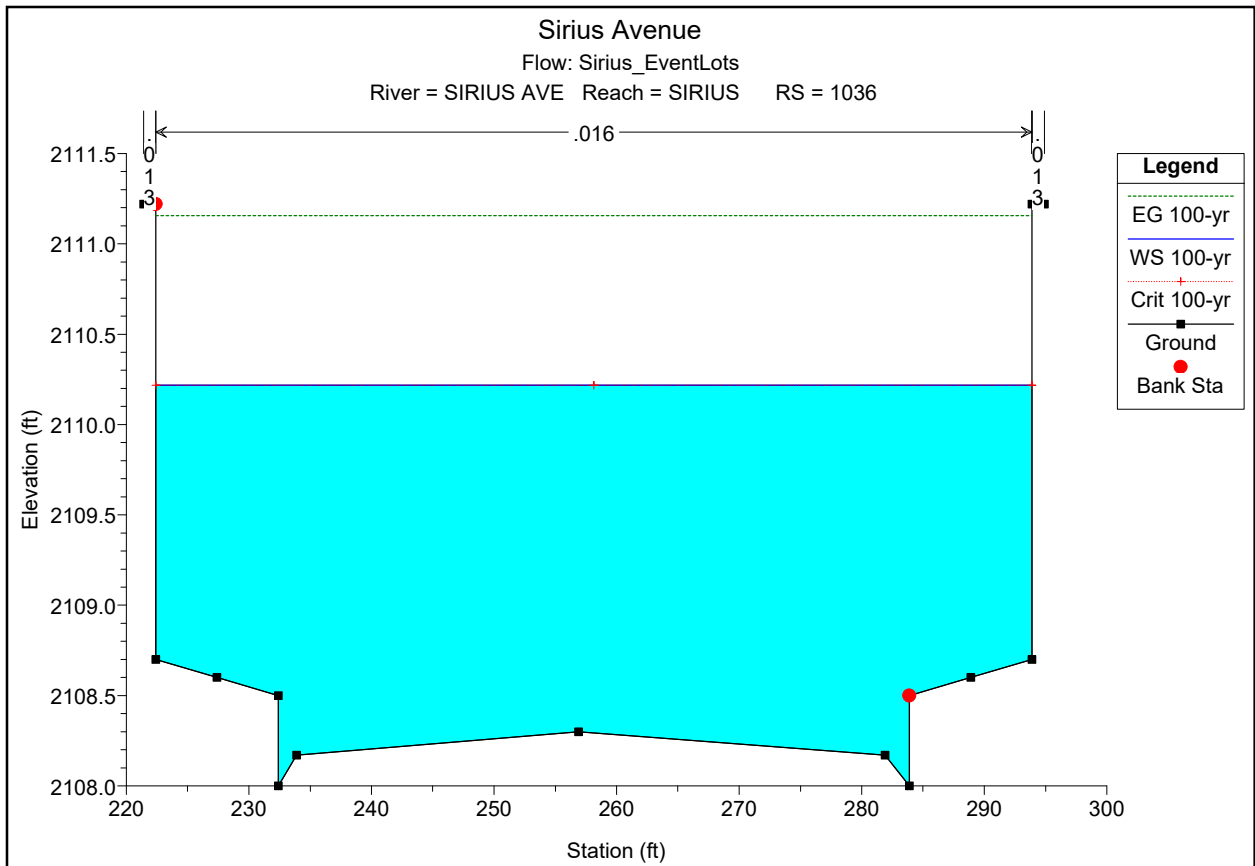

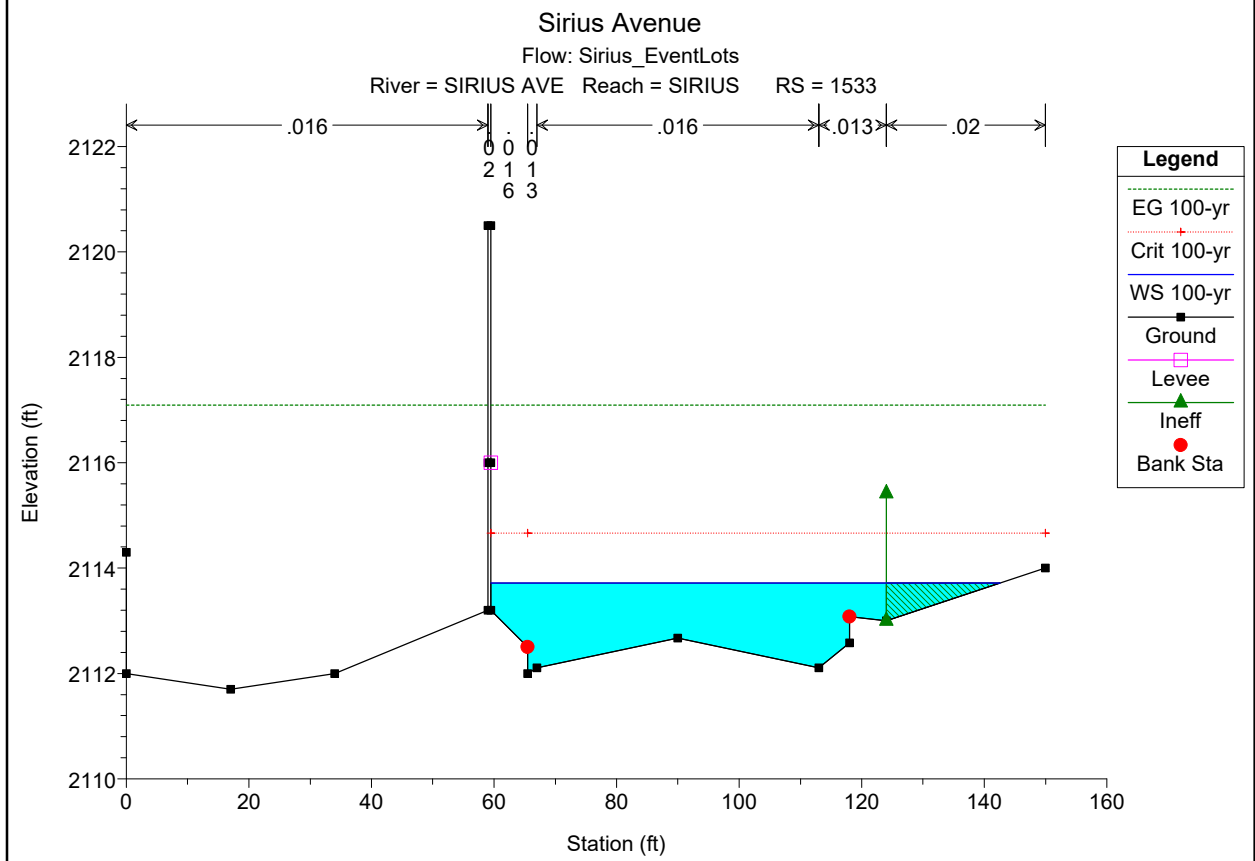
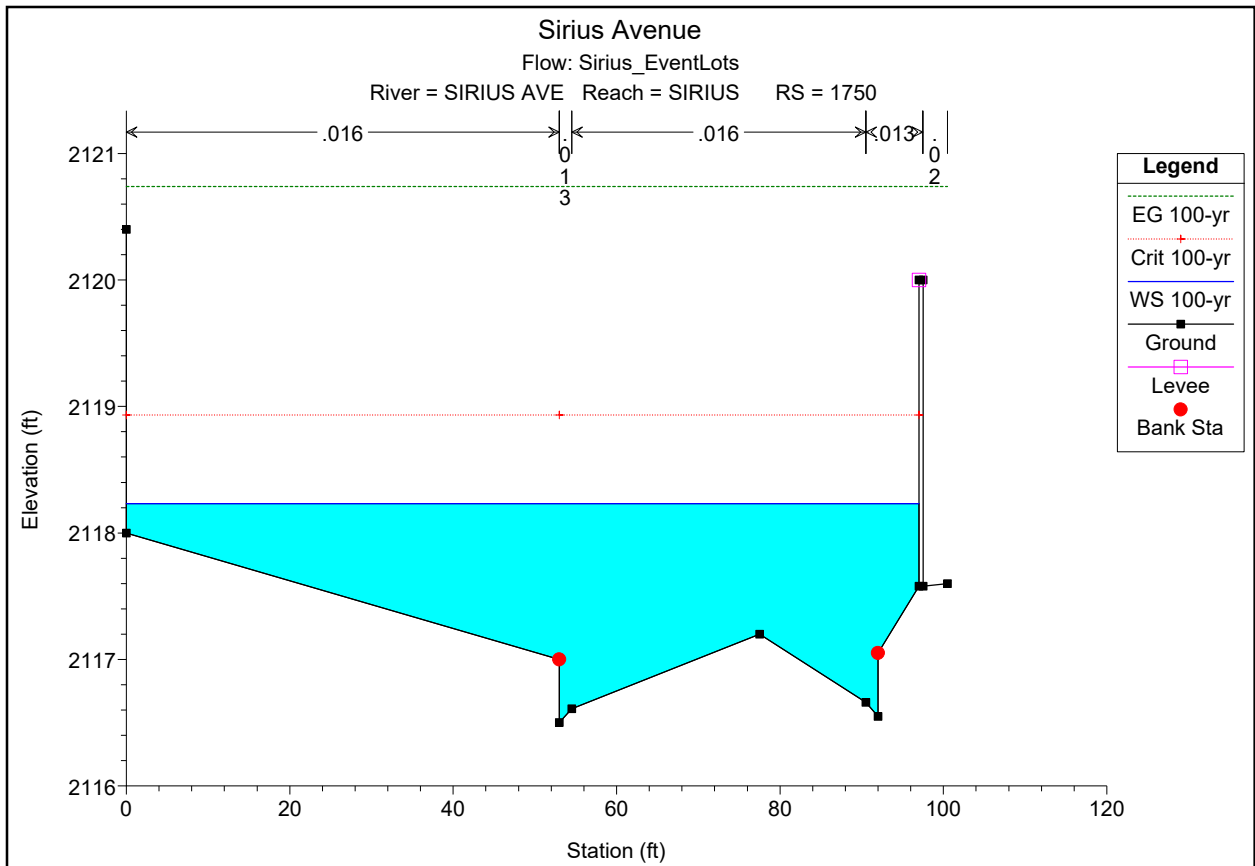

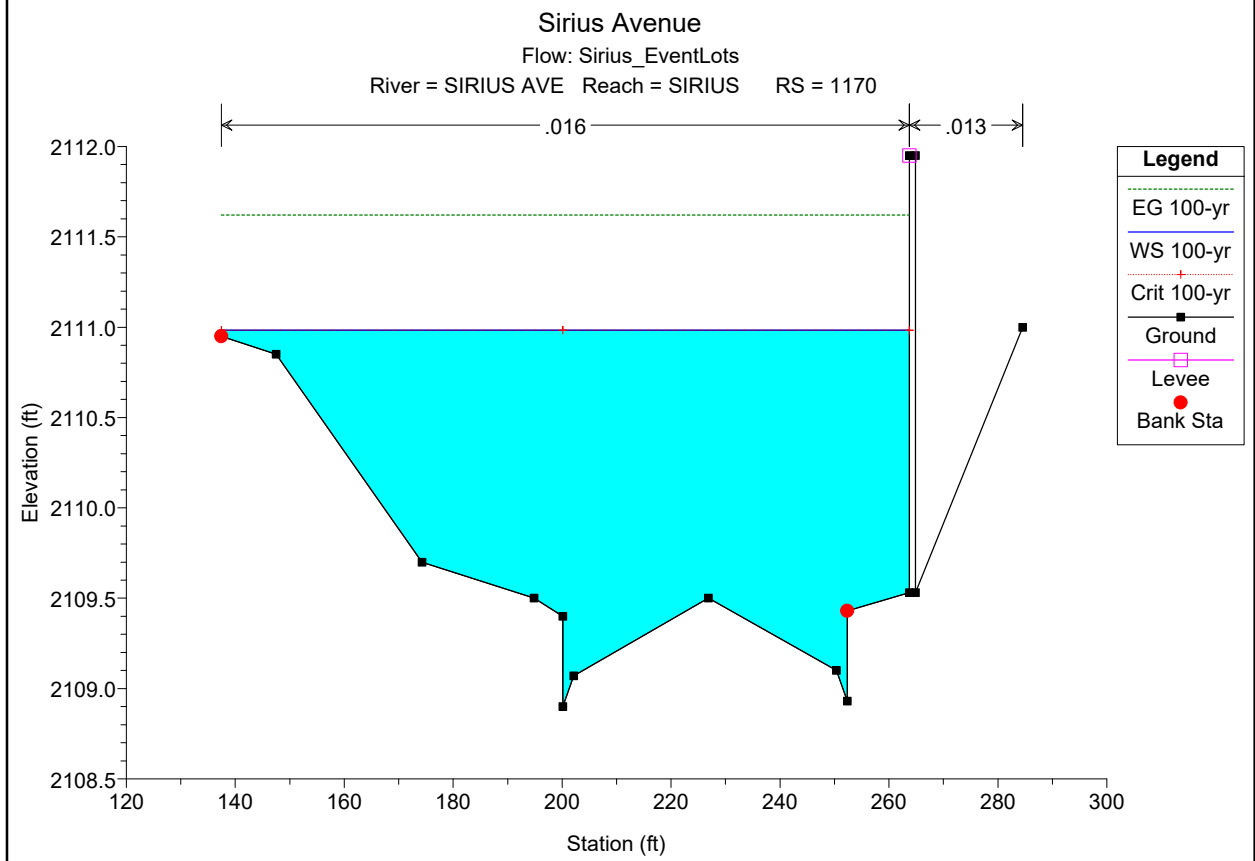
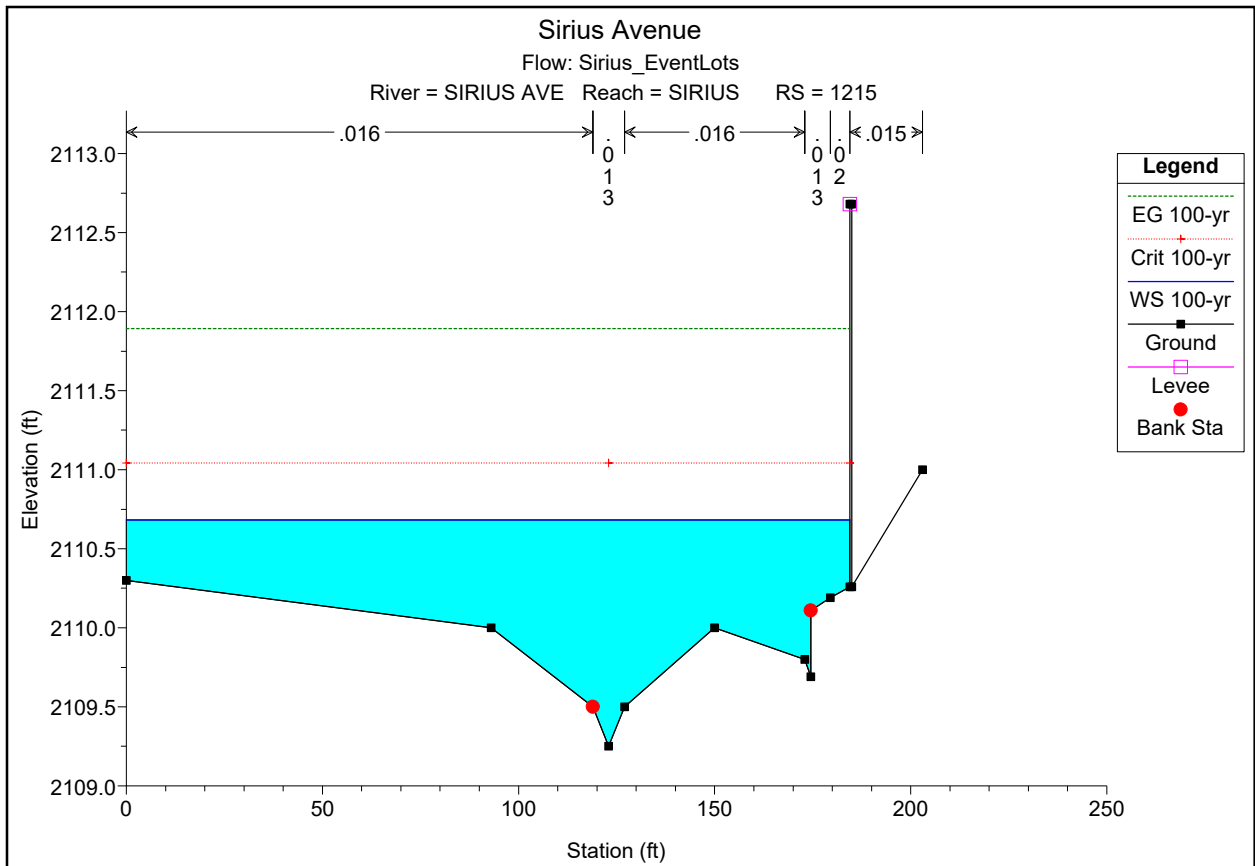

HEC-RAS Plan: PROP2UP\_2024 River: SIRIUS AVE Reach: SIRIUS Profile: 100-yr

Reach	River Sta	Profile	Q US (cfs)	Q Leaving Total (cfs)	Q DS (cfs)	Q Weir (cfs)	Q Gates (cfs)	Wr Top Width (ft)	Weir Max Depth (ft)	Weir Avg Depth (ft)	Min El Weir Flow (ft)	E.G. US. (ft)	W.S. US. (ft)	E.G. DS (ft)	W.S. DS (ft)
SIRIUS	1245	100-yr	1158.00	115.32	1044.38	115.32		60.00	1.17	0.73	2109.80	2112.38	2110.97	2111.71	2110.88
SIRIUS	1177	100-yr	1095.45	0.00	1044.38	0.00					2110.95	2111.71	2110.89	2111.62	2110.98

FFE Hydraulic Sections															
ONSITE SECTION	TRIBUTARY BASINS	SLOPE %	Q <sub>100</sub> (cfs)	FLOW DEPTH (ft)	FLOW LINE (ft)	FLOW LINE + 2D (ft)	WSE (ft)	FFE BLDG1 (ft)	FFE BLDG2 (ft)	FFE BLDG3 (ft)	FFE BLDG4 (ft)	FFE BLDG5 (ft)	FFE BLDG6 (ft)	BLDG PROTECTED?	BLDG PROTECTED?
ONH	ONH	0.61	2	0.15	2107.25	2107.55	-	2108.00	2108.00	-	-	-	-	YES	YES
ONP1	ONP	1.24	1	0.11	2111.30	2111.52	-	-	-	-	2111.50	-	2111.50	**	**
ONP2 South	ONP	1.55	1	0.14	2111.30	2111.58	-	-	-	-	-	-	2111.50	**	-
ONP2 North	ONP	0.10	1	0.20	2107.50	2107.90	-	2108.00	-	-	-	-	-	YES	-
ONR1	ONR	0.58	1	0.12	2111.40	2111.64	-	-	-	-	2111.50	-	2111.50	**	**
ONR2	1/2ONR	0.10	0.5	0.18	2110.85	2111.21	-	-	-	-	2111.50	2111.40	-	YES	YES
RD	**CRCPS06 + ONP + ONL + ONM + ONQ + ONR + ONS + ONT + ONV + ONW + ***RD	0.25	2548	8.56	-	-	2108.42	2108.00	-	-	-	-	-	*	-
ST2	**CRCPS06 + ONR + ONS + ONT + ONV + ONW + ***RD	0.90	2543.5	6.35	-	-	2108.06	-	-	-	-	-	2111.50	YES	-
*F-F(ROAD)	**CRCPS06	0.70	2538	3.58	-	-	2110.58	-	-	-	-	2111.40	-	YES	-
RA	**PS08(OF1) + 115-cfs + ONG + ONK + ONN + ONO + ONU	0.45	137.5	0.97	2108.65	2111.12	-	-	-	-	2111.50	-	-	YES	-
RA1	**PS08(OF1) + 115-cfs + ONC + ONG + ONK + ONN + ONO + ONU + 1/2OF5 + 1/2RA	0.68	140.5	1.45	2107.60	2110.55	-	-	2108.00	-	-	-	-	*	-
MA2A	**PS08(OF1) + **PS08(OF3) + **PS08(OF5) + 115-cfs + ONA + ONB + ONC + OND + ONE + ONF + ONG + ONH + ONK + ONN + ONO + ONU + ONX + RA	0.30	232.5	1.30	2102.30	2105.10	-	2108.00	-	-	-	-	-	YES	-
MA2C	**PS08(OF1) + **PS08(OF3) + **PS08(OF5) + 115-cfs + ONA + ONB + ONC + OND + ONG + ONK + ONN + ONO + ONU + RA	1.40	227.5	0.92	2105.61	2108.03	-	-	2108.00	-	-	-	-	*	-

\*Solid Grouted Flood Walls have been provided adjacent to building

\*\*Trench Drains have been provided adjacent to building