

2001 Eagle Trace Way

By definition, 2001 Eagle Trace Way is defined by Title 19.20 as a "Lot, Flag." A flag lot is a lot having access or an easement to a public or private street by a narrow, private right-of-way.

The rear yard of 2001 Eagle Trace Way was determined by staff by referencing Title 19.20 "Lot Line, Rear" which states, "the property line opposite and most distant from the front property line. In the case of a triangular or otherwise irregularly shaped lot, a line ten feet in length entirely within the lot, parallel to and at a maximum distance from the front property line." As demonstrated in the figure below, the 10-foot line parallel to the front property line demonstrates the area determined to be the rear yard.

"Lot Line, Front" as defined by Title 19.20 is "the property line separating a lot from a street right-of-way."

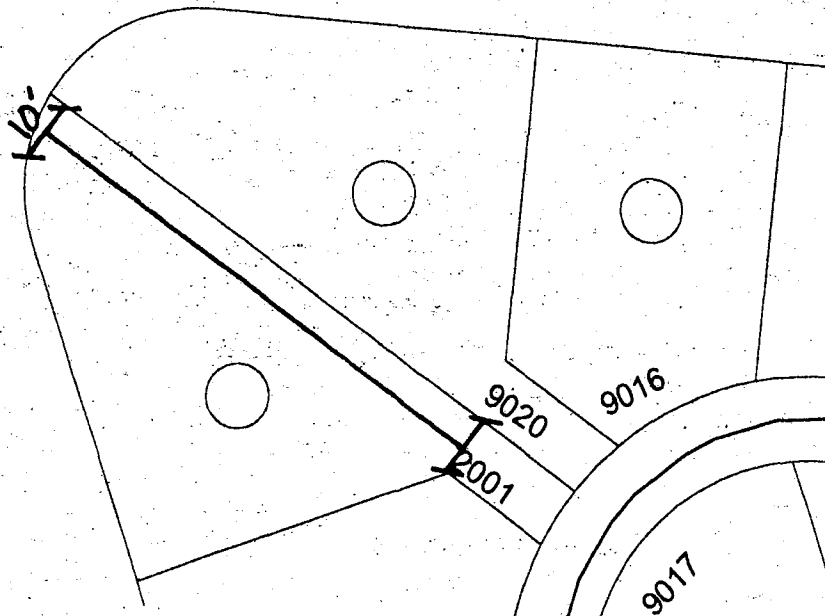

LVMC Title 19.08.040.C.4.a R-PD (Residential Planned Development) District:

Development Standards: The development standards for a project shall be established by the approval of an R-PD District and the approved Site Development Plan as described in Subchapter 19.18.050. Development standards shall include minimum front, side and rear setbacks, maximum building heights, wall and fence design and heights, parking standards, landscaping and other design and development criteria.

Per Title 19.08 .040.B.4.a, "a patio cover may encroach to within five feet from the rear and side property lines in the R-D, R-1, R-CL, R-2, R-3, R-4, R-5, R-MH, and R-MHP zoning districts and may encroach to within 15 feet from the rear and side property lines in the U, R-A and R-E zoning districts. This does not include the R-PD district. Homes within the R-PD district must adhere to the minimum setback requirements set forth by the Site Development Plan.

Submitted after final agenda

Date 11/6/08 Item 18

VAR-30268

11/06/08 PC

Telephone Protest/ Support Log

Meeting Date: NOV. 6th, 2008 Case Number: VAR-30268

Date: 10-1-08
Name: Mr & Mrs. Richard Remark
Address: 9020 EMERALD HILLS
Phone: 252-7245
 PROTEST SUPPORT
it's right upto the party line

Date: _____
Name: _____
Address: _____
Phone: _____
 PROTEST SUPPORT

Date: _____
Name: _____
Address: _____
Phone: _____
 PROTEST SUPPORT

Date: _____
Name: _____
Address: _____
Phone: _____
 PROTEST SUPPORT

Date: _____
Name: _____
Address: _____
Phone: _____
 PROTEST SUPPORT

Date: _____
Name: _____
Address: _____
Phone: _____
 PROTEST SUPPORT

Submitted after final agenda
Date P Item 18

751 S. Fourth Street
Las Vegas, Nevada 89101-2986

**Return Service Requested
Official Notice of Public Hearing**

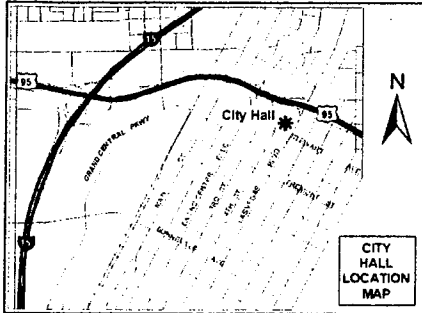

If you wish to file your protest or support on this request, check the appropriate box below and return this card in an envelope with postage to the Planning & Development Department at the address listed above or fax this side of this card to (702) 385-7268. If you would like to contact your Council Representative, please call (702) 229-6405.

I SUPPORT
this Request

I OPPOSE
this Request

Please use available blank space on card for your comments.

VAR-30268

Planning Commission Meeting of 11/6/2008

PRESORTED
FIRST CLASS



UNIT
02 1M
0004239954
MAILED FROM ZIP CODE 89101
\$ 00.39⁴
OCT 24 2008
EDDIE ROWLES

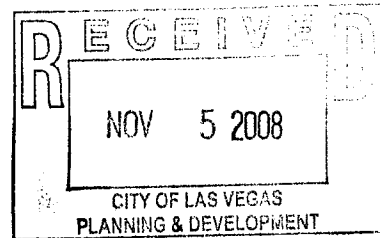

16305415374
MIRAMONTES OMAR
4146 MENDEZ ST #122
LONG BEACH CA 90815-5157

Case: VAR-30268

Submitted after final agenda

Date **P** Item **18**

Las Vegas, Nevada 89101-2986

**Return Service Requested
Official Notice of Public Hearing**

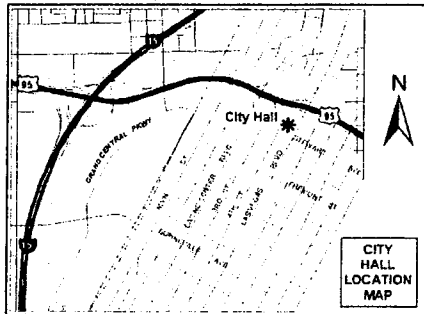

If you wish to file your protest or support on this request, check the appropriate box below and return this card in an envelope with postage to the Planning & Development Department at the address listed above or fax this side of this card to (702) 385-7268. If you would like to contact your Council Representative, please call (702) 229-6405.

I SUPPORT
this Request

I OPPOSE
this Request

Please use available blank space on card for your comments.

VAR-30268

Planning Commission Meeting of 11/6/2008

PRESORT
FIRST CLASS



5
02 1M
0004239954
\$ 00.39⁴
OCT 24 2008
MAILED FROM ZIP CODE 89101

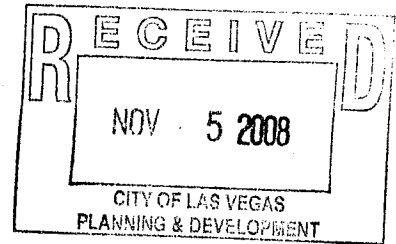

16305415129
MIRAMONTES OMAR
4146 E MENDEZ ST #122
LONG BEACH CA 90815-5157

Case: VAR-30268

Submitted after final agenda
Date P Item 18

City of Las Vegas
Planning & Development Department
Development Services Center
731 S. Fourth Street
Las Vegas, Nevada 89101-2986

Return Service Requested
Official Notice of Public Hearing

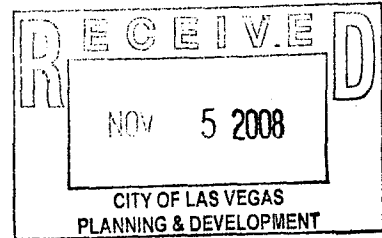
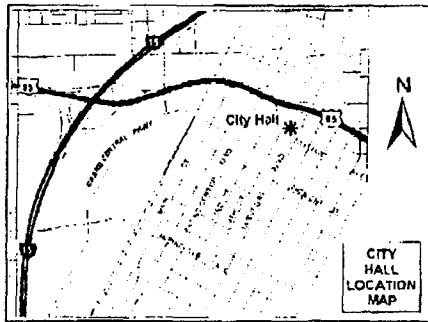

If you wish to file your protest or support on this request, check the appropriate box below and return this card in an envelope with postage to the Planning & Development Department at the address listed above or fax this side of this card to (702) 385-7268. If you would like to contact your Council Representative, please call (702) 229-6405.

I SUPPORT
this Request

I OPPOSE
this Request

Please use available blank space on card for your comments.

VAR-30268

Planning Commission Meeting of 11/6/2008

Case: VAR-30268

16305312015
SWANSON RICHARD A JR
9005 RIVERS EDGE DR
LAS VEGAS NV 89117-5426

HAUDES11 28117



Submitted after final agenda	
Date	P
Item	18

Nov 03 08 04:15p Andrea Swanson

City of Las Vegas
 Planning & Development Department
 Development Services Center
 731 S. Fourth Street
 Las Vegas, Nevada 89101-2986

**Return Service Requested
 Official Notice of Public Hearing**

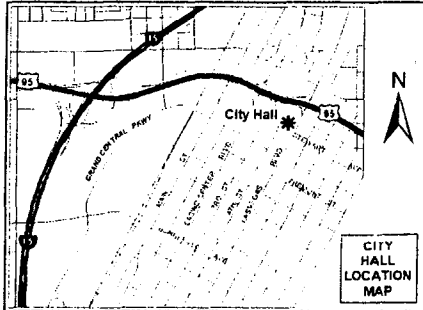

If you wish to file your protest or support on this request, check the appropriate box below and return this card in an envelope with postage to the Planning & Development Department at the address listed above or fax this side of this card to (702) 385-7268. If you would like to contact your Council Representative, please call (702) 229-6405.

I SUPPORT
 this Request

I OPPOSE
 this Request

Please use available blank space on card for your comments.

VAR-30268

Planning Commission Meeting of 11/6/2008

HAU5S11 89117



PRESORTED
 FIRST CLASS

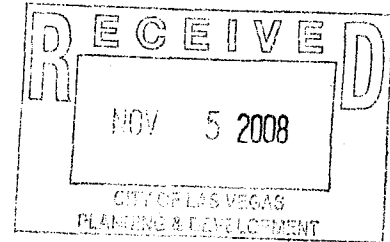

16305220036 Case: VAR-30268
 STEIRER LLOYD S & NINA C
 1621 STARSIDE DR
 LAS VEGAS NV 89117-5434

Submitted after final agenda
 Date **P** Item **18**

City of Las Vegas
 Planning & Development Department
 Development Services Center
 731 S. Fourth Street
 Las Vegas, Nevada 89101-2986

**Return Service Requested
 Official Notice of Public Hearing**

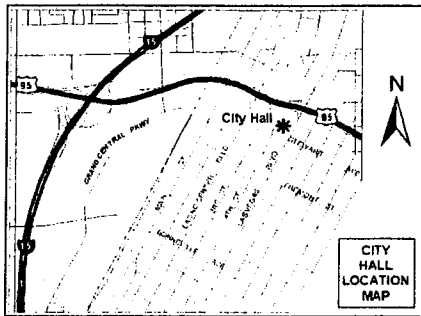

If you wish to file your protest or support on this request, check the appropriate box below and return this card in an envelope with postage to the Planning & Development Department at the address listed above or fax this side of this card to (702) 385-7268. If you would like to contact your Council Representative, please call (702) 229-6405.



I SUPPORT
 this Request



I OPPOSE
 this Request

Please use available blank space on card for your comments.

VAR-30268

Planning Commission Meeting of 11/6/2008

PRESORTED
 FIRST CLASS



UNITED STATES POSTAGE
 \$ 00.39⁴
 02 1M
 0004239954 OCT 24 2008
 MAILED FROM ZIP CODE 89101

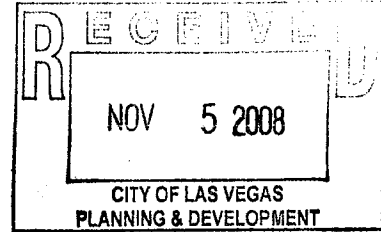

16305311020
 LUTZ MARILYN W
 1828 GLENWILLOW DR
 LAS VEGAS NV 89117-5344

Case: VAR-30268

HAUS11 89117



Submitted after final agenda
 Date **A** Item **18**

City of Las Vegas
 Planning & Development Department
 Development Services Center
 731 S. Fourth Street
 Las Vegas, Nevada 89101-2986

**Return Service Requested
 Official Notice of Public Hearing**

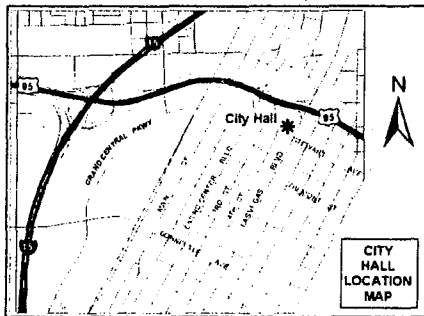

If you wish to file your protest or support on this request, check the appropriate box below and return this card in an envelope with postage to the Planning & Development Department at the address listed above or fax this side of this card to (702) 385-7268. If you would like to contact your Council Representative, please call (702) 229-6405.



I SUPPORT
 this Request



I OPPOSE
 this Request

Please use available blank space on card for your comments.

VAR-30268

Planning Commission Meeting of 11/6/2008

HAU0511 92669



PRESORTED
 FIRST CLASS



UNITED STATES POSTAGE
 02 1M \$ 00.394
 0004239954 OCT 24 2008
 MAILED FROM ZIP CODE 89101

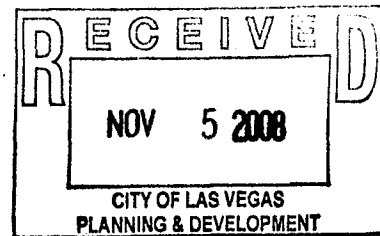

Case: VAR-30268
 16305415323
 TIBORCZSZECHY GABRIELLA & ROGER
 275 S WILLOW SPRINGS
 ORANGE CA 92869-5641

Submitted after final agenda
 Date **A** Item **18**

City of Las Vegas
Planning & Development Department
Development Services Center
731 S. Fourth Street
Las Vegas, Nevada 89101-2986

Return Service Requested
Official Notice of Public Hearing

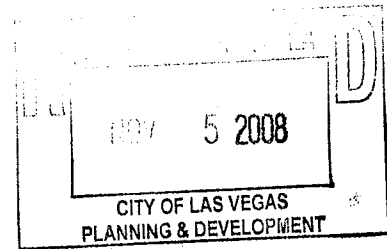
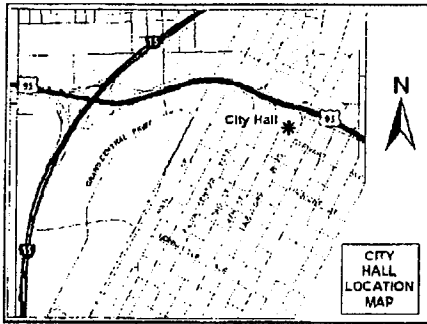

If you wish to file your protest or support on this request, check the appropriate box below and return this card in an envelope with postage to the Planning & Development Department at the address listed above or fax this side of this card to (702) 385-7268. If you would like to contact your Council Representative, please call (702) 229-6405.



I SUPPORT
this Request



I OPPOSE
this Request

Please use available blank space on card for your comments.

VAR-30268

Planning Commission Meeting of 11/6/2008

Case: VAR-30268
16305410021
ANDREWS REVOCABLE TRUST
2108 BAY HILL DR
LAS VEGAS NV 89117-5726

NOV 11 2008



Submitted after final agenda

Date

A

Item

18

Nov 03 08 09:27a B.C.Andrews

City of Las Vegas
 Planning & Development Department
 Development Services Center
 731 S. Fourth Street
 Las Vegas, Nevada 89101-2986

**Return Service Requested
 Official Notice of Public Hearing**

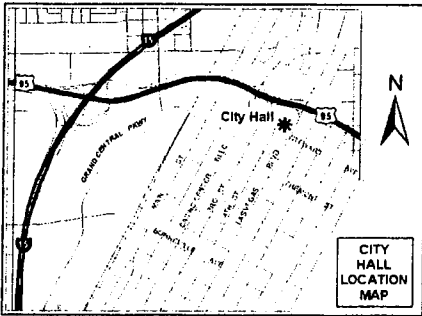

If you wish to file your protest or support on this request, check the appropriate box below and return this card in an envelope with postage to the Planning & Development Department at the address listed above or fax this side of this card to (702) 385-7268. If you would like to contact your Council Representative, please call (702) 229-6405.



I SUPPORT
 this Request



I OPPOSE
 this Request

Please use available blank space on card for your comments.

VAR-30268

Planning Commission Meeting of 11/6/2008

PRESORTED
 FIRST CLASS

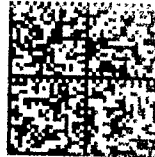

UNITED STATES POSTAGE
 \$ 00.394
 OCT 24 2008
 MAILED FROM ZIP CODE 89101

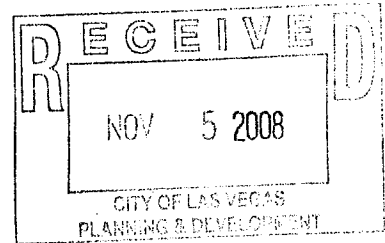

Case: VAR-30268
 16305319012
 TRENT WILLIAM L & SHARON FAM TR
 9017 EMERALD HILL WY
 LAS VEGAS NV 89117-5741

HAUDES11 89117



Submitted after final agenda
 Date **A** Item **1B**

City of Las Vegas
Planning & Development Department
Development Services Center
731 S. Fourth Street
Las Vegas, Nevada 89101-2986

Return Service Requested
Official Notice of Public Hearing

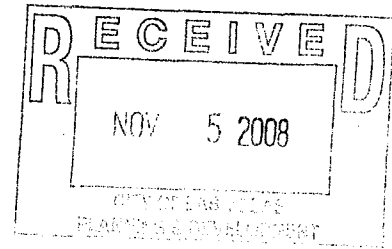
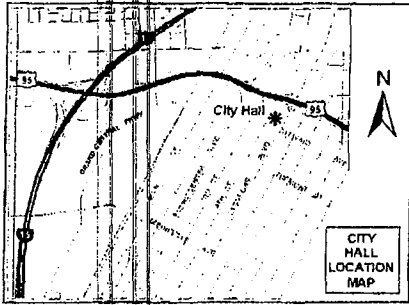

Fax Meul

If you wish to file your protest or support on this request, check the appropriate box below and return this card in an envelope with postage to the Planning & Development Department at the address listed above or fax this side of this card to (702) 385-7268. If you would like to contact your Council Representative, please call (702) 229-6405.

Case: VAR-30268

16305415121
CARBAYO ANTONIO
415 N SYCAMORE DR #101
SANTA ANA CA 92701-4607

I SUPPORT
this Request

I OPPOSE
this Request

Please use available blank space on card for your comments.

VAR-30268

Planning Commission Meeting of 11/6/2008

HAUDE11 92701



Submitted after final agenda
Date **A** year **18**

City of Las Vegas
 Planning & Development Department
 Development Services Center
 731 S. Fourth Street
 Las Vegas, Nevada 89101-2986

**Return Service Requested
 Official Notice of Public Hearing**

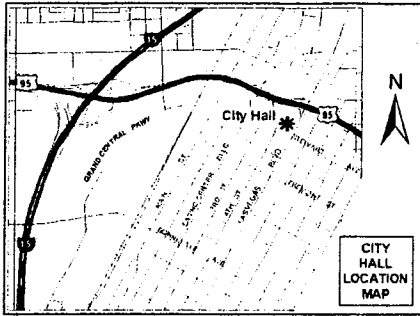

If you wish to file your protest or support on this request, check the appropriate box below and return this card in an envelope with postage to the Planning & Development Department at the address listed above or fax this side of this card to (702) 385-7268. If you would like to contact your Council Representative, please call (702) 229-6405.



I SUPPORT
 this Request



I OPPOSE
 this Request

Please use available blank space on card for your comments.

VAR-30268

Planning Commission Meeting of 11/6/2008

89117 115140



PRESORTED
 FIRST CLASS



UNITED STATES POSTAGE
 02 1M \$ 00.394
 0004289954 OCT 24 2008
 MAILED FROM ZIP CODE 89101

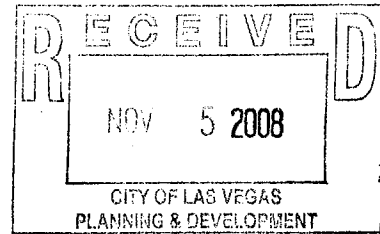

Case: VAR-30268
 16305319003
 BELL BRENT & SUZANNE FAMILY TR
 2001 EAGLE TRACE WY
 LAS VEGAS NV 89117-5743

Submitted after final agenda
 Date **A** Item **18**