



**PLANNING & DEVELOPMENT DEPARTMENT**

**STATEMENT OF FINANCIAL INTEREST**

Case Number: **VAR-28973** APN: 138-36-407-016

Name of Property Owner: Juan Anderson

Name of Applicant: Juan Anderson

Name of Representative: Juan Anderson

To the best of your knowledge, does the Mayor or any member of the City Council or Planning Commission have any financial interest in this or any other property with the property owner, applicant, the property owner or applicant's general or limited partners, or an officer of their corporation or limited liability company?

           Yes   X   No

If yes, please indicate the member of the City Council or Planning Commission who is involved and list the name(s) of the person or persons with whom the City Official holds an interest. Also list the Assessor's Parcel Number if the property in which the interest is held is different from the case parcel.

City Official: \_\_\_\_\_

Partner(s): \_\_\_\_\_

APN: 138-36-407-016

Signature of Property Owner: *Juan Anderson*

Print Name: Juan Anderson

Subscribed and sworn before me  
This 31<sup>st</sup> day of July, 2008

Ada Fino  
Notary Public in and for said County and State

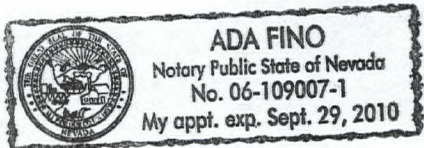

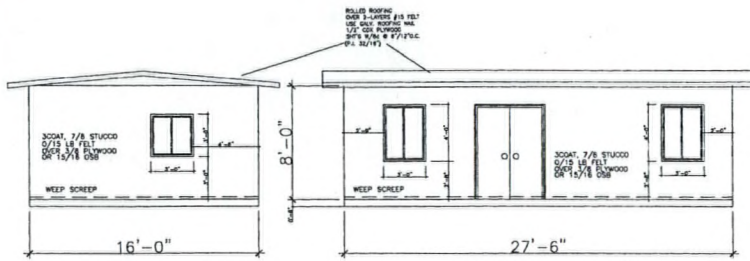

SOUTH VIEW  
SCALE 1/4"=1'-0"

WEST VIEW  
SCALE 1/4"=1'-0"

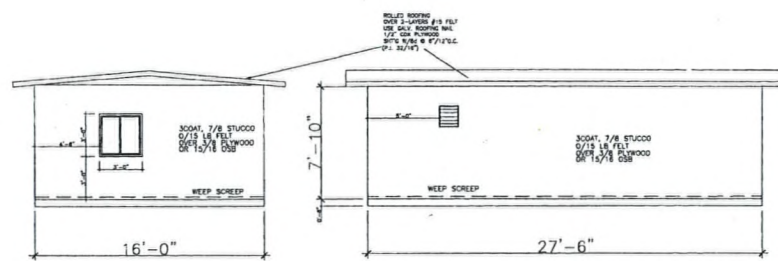

NORTH VIEW  
SCALE 1/4"=1'-0"

EAST VIEW  
SCALE 1/4"=1'-0"

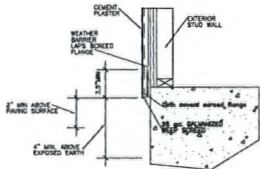

WEEP Screenshot DETAIL  
NO SCALE

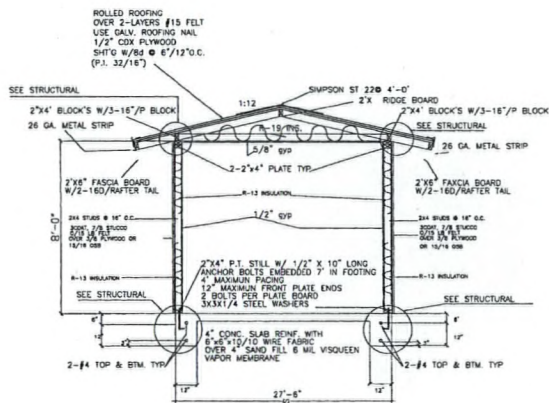

WALL SEC "W"  
SCALE NOTE: SEC. IS NOT DRAWN TO SCALE.

DOOR AND WINDOW / SCHEDULE

- (A) 5'-0"x6'-8" FRENCH DOOR
- (1) 3'-0"x3'-0" A. SLIDE WIND.
- (2) 3'-0"x4'-0" A. SLIDE WIND.
- (3) 14X16 WALL-MOUNTED UNIT

NOTE: MUST COMPLY WITH REC.

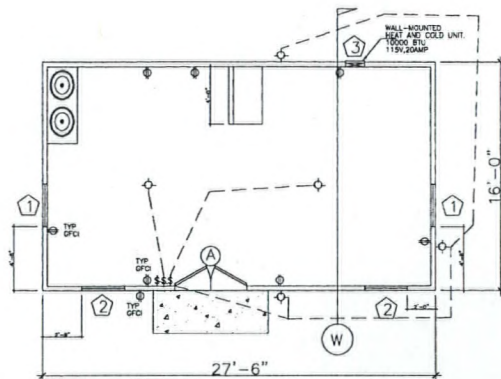

FLOOR PLAN SCALE 1/4"=1'-0"

ELECTRICAL SYMBOLS

- LIGHT
  - SWITCH
  - OUTLET
- ALL BRANCH CIRCUITS SHALL BE PROTECTED BY FUSES OR CIRCUIT BREAKERS. ALL BRANCH CIRCUITS SHALL BE PROTECTED BY FUSES OR CIRCUIT BREAKERS. ALL BRANCH CIRCUITS SHALL BE PROTECTED BY FUSES OR CIRCUIT BREAKERS.

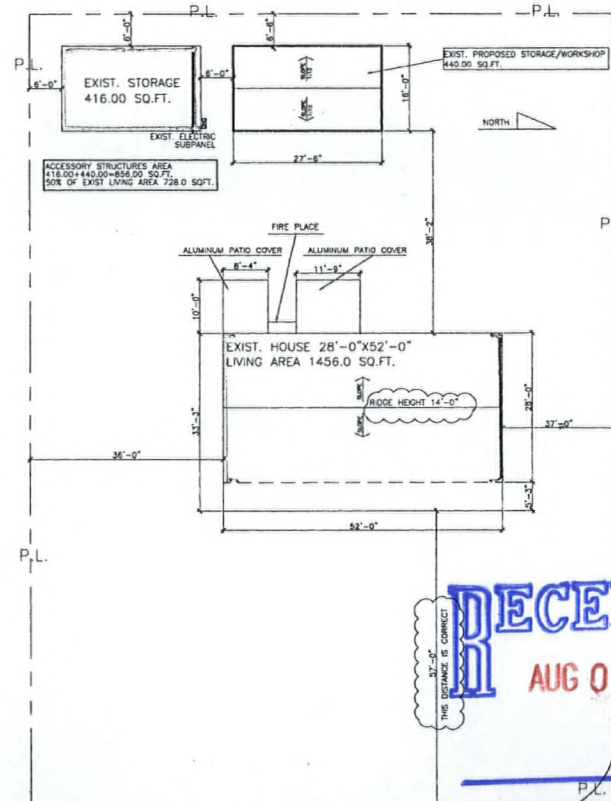

1000 MOHAWK ST. LV NV 89107

PLOT PLAN SCALE 3/32"=1'-0"

**RECEIVED**  
AUG 01 2008

**VAR-28973**  
**REVISED**  
**08/28/08 PC**

OWNER/BUILDER

REV.	DATE	DESCRIPTION

PROPOSED BY: JUAN ANDERSON  
ADDRESS JOB: 1000 MOHAWK ST. LV NV 89107  
JOB: ACCESSORY STRUCTURE  
PHONE: 324-5191

SHEET  
1