



**PLANNING & DEVELOPMENT DEPARTMENT**

**STATEMENT OF FINANCIAL INTEREST**

Case Number: SUP-28216 APN: 162-03-513-005

Name of Property Owner: HUNTRIDGE SHOPPING CENTER LLC

Name of Applicant: WET PAINT MEDIA LLC

Name of Representative: ALFRED WENDLER

To the best of your knowledge, does the Mayor or any member of the City Council or Planning Commission have any financial interest in this or any other property with the property owner, applicant, the property owner or applicant's general or limited partners, or an officer of their corporation or limited liability company?

Yes

No

If yes, please indicate the member of the City Council or Planning Commission who is involved and list the name(s) of the person or persons with whom the City Official holds an interest. Also list the Assessor's Parcel Number if the property in which the interest is held is different from the case parcel.

City Official: \_\_\_\_\_

Partner(s): \_\_\_\_\_

APN: \_\_\_\_\_

Signature of Property Owner: Paul J. Kellogg

Print Name: Paul L. Kellogg

Subscribed and sworn before me

This 24<sup>th</sup> day of April, 2008  
Bobbie Smith

Notary Public in and for said County and State

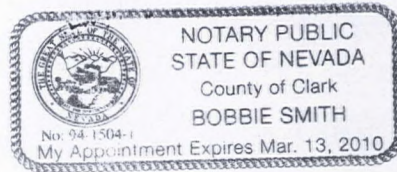

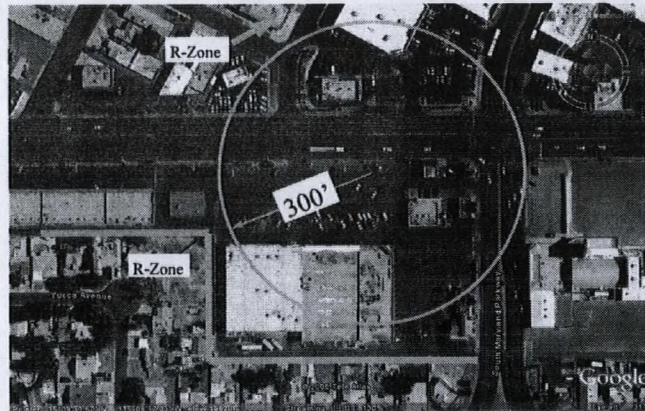
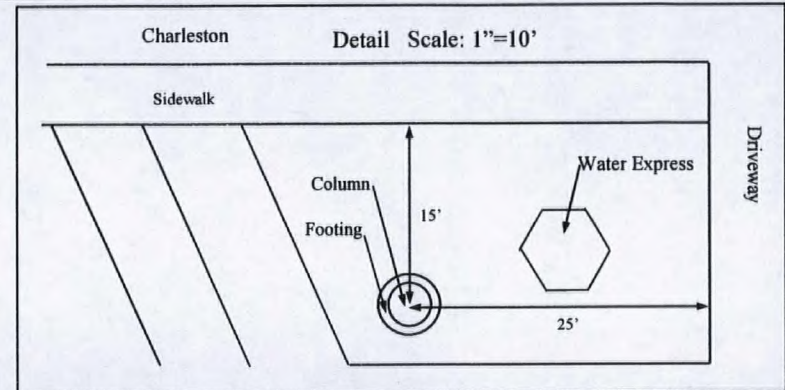
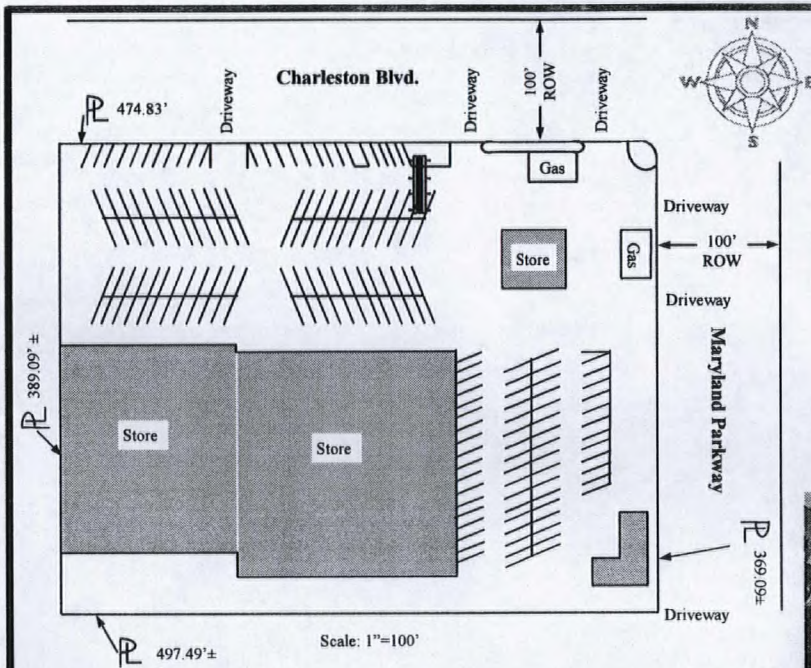

**GENERAL NOTES**

1. Not within 300' radius of another off premise sign.
2. Not within 300' radius of residential use.
3. No parking spaces will be taken for this location.

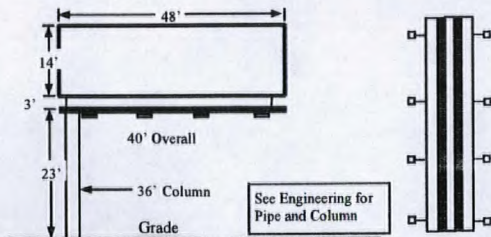

Owner	
Huntridge Shopping Center LLC	
Location	
1120 E. Charleston	
Date	Drawn By
4-22-08	AW
 526-4586	

**SUP-28216**  
**07/10/08 PC**

RECEIVED

MAY 20 2008