



**PLANNING & DEVELOPMENT DEPARTMENT**

**STATEMENT OF FINANCIAL INTEREST**

Case Number: SUP-25135 APN: 162-04-406-011

Name of Property Owner: ~~Mordechai Yerushalmi~~ The Jewelers Inc.  
401 K Prof. Sharing Plan, Trust  
Name of Applicant: Mountain View Estates  
R.H.

To the best of your knowledge, does the Mayor or any member of the City Council or Planning Commission have any financial interest in this or any other property with the property owner, applicant, the property owner or applicant's general or limited partners, or an officer of their corporation or limited liability company?

           Yes       X       No

If yes, please indicate the member of the City Council or Planning Commission who is involved and list the name(s) of the person or persons with whom the City Official holds an interest. Also list the Assessor's Parcel Number if the property in which the interest is held is different from the case parcel.

City Official: N/A

Partner(s): N/A N/A

APN: N/A

Signature of Property Owner/Authorized Agent: [Signature]

Print Name: Mordechai Yerushalmi

Subscribed and sworn before me

This 28 day of August, 2007  
Karen Franke Ferguson  
Notary Public in and for said County and State

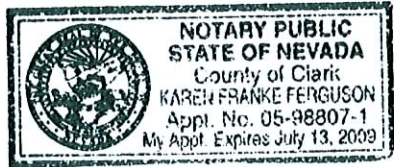

RECEIVED

OCT 19 2007

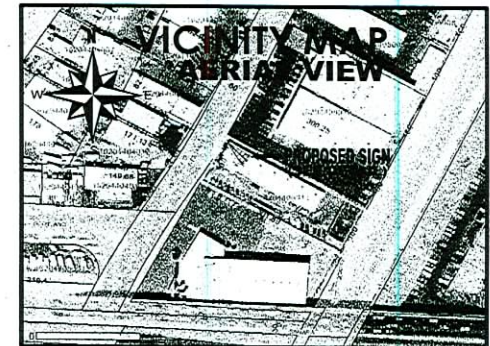
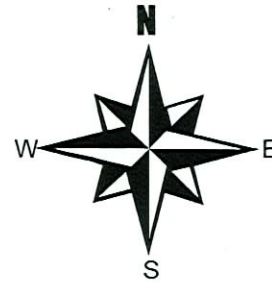
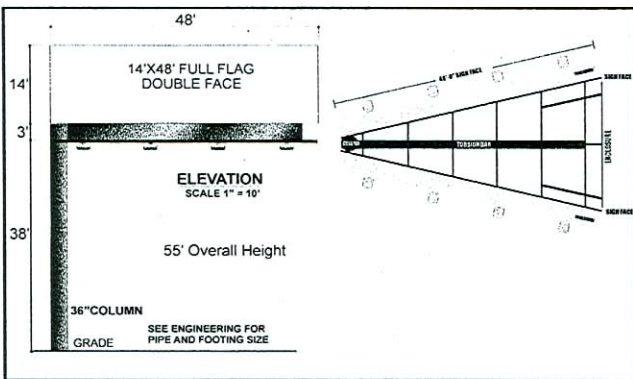

**TOP VIEW**  
**SCALE 1" = 20'**  
**DETAIL**

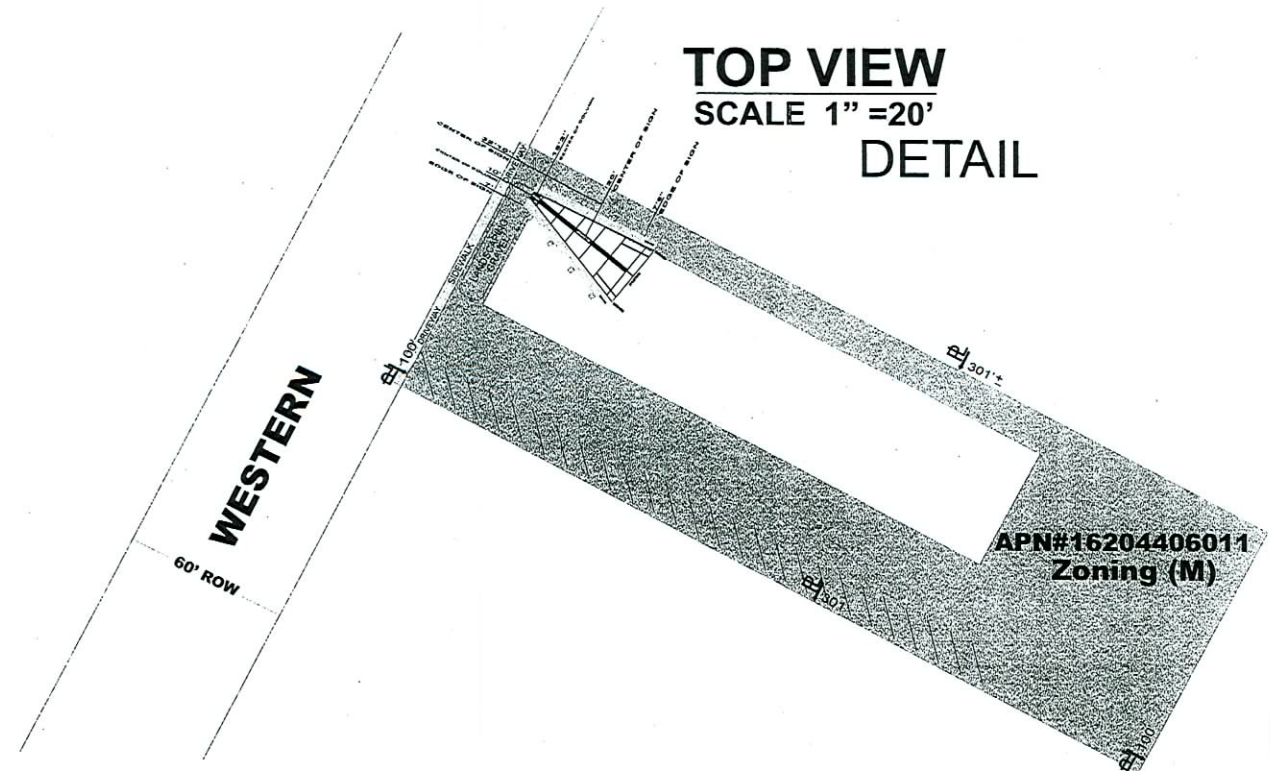

- GENERAL NOTES**
1. Not within 300 foot radius of another off-premise billboard.
  2. Not within 300 foot radius of residential use.
  3. No parking spaces will be taken for this location.

**MICHAEL J. MCDONALD**  
 ALPHA OMEGA STRATEGIES  
 4908 CARMEN BLVD.  
 LAS VEGAS, NV. 89108  
 PH: 702-592-1990

**JONES**  
 4145 W. TECO AVE / LAS VEGAS, NV 89118 / 702-845-0092

OWNER:  
**JEWELER'S 401K PFT SHR PL**

SCALE: NOTED	APPROVED BY:	DRAWN BY: TOM JONES
DATE: 9-25-07		REVISED:

LOCATION:  
**2411 WESTERN AVE UT H**

APN# 16204406011	DRAWING NUMBER: <b>298</b>
------------------	-------------------------------

**VAR-25137**  
**SUP-25135**  
**12/06/07 PC**

RECEIVED  
 OCT 19 2007