



PLANNING & DEVELOPMENT DEPARTMENT

STATEMENT OF FINANCIAL INTEREST

Case Number: SR 21620 APN: 138-34-613-028

Name of Property Owner: Timothy W. Volz

Name of Applicant: Timothy W. Volz

Name of Representative: Lois Tarkanian

To the best of your knowledge, does the Mayor or any member of the City Council or Planning Commission have any financial interest in this or any other property with the property owner, applicant, the property owner or applicant's general or limited partners, or an officer of their corporation or limited liability company?

Yes

No

If yes, please indicate the member of the City Council or Planning Commission who is involved and list the name(s) of the person or persons with whom the City Official holds an interest. Also list the Assessor's Parcel Number if the property in which the interest is held is different from the case parcel.

City Official: _____

Partner(s): _____

APN: _____

Signature of Property Owner: *Timothy W. Volz*
Print Name: Timothy W. Volz

Subscribed and sworn before me

This 26th day of April, 2007
Joyce A. Coffin
Notary Public in and for said County and State

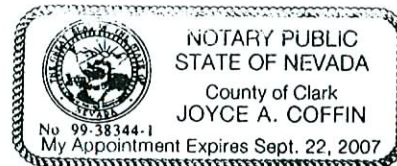

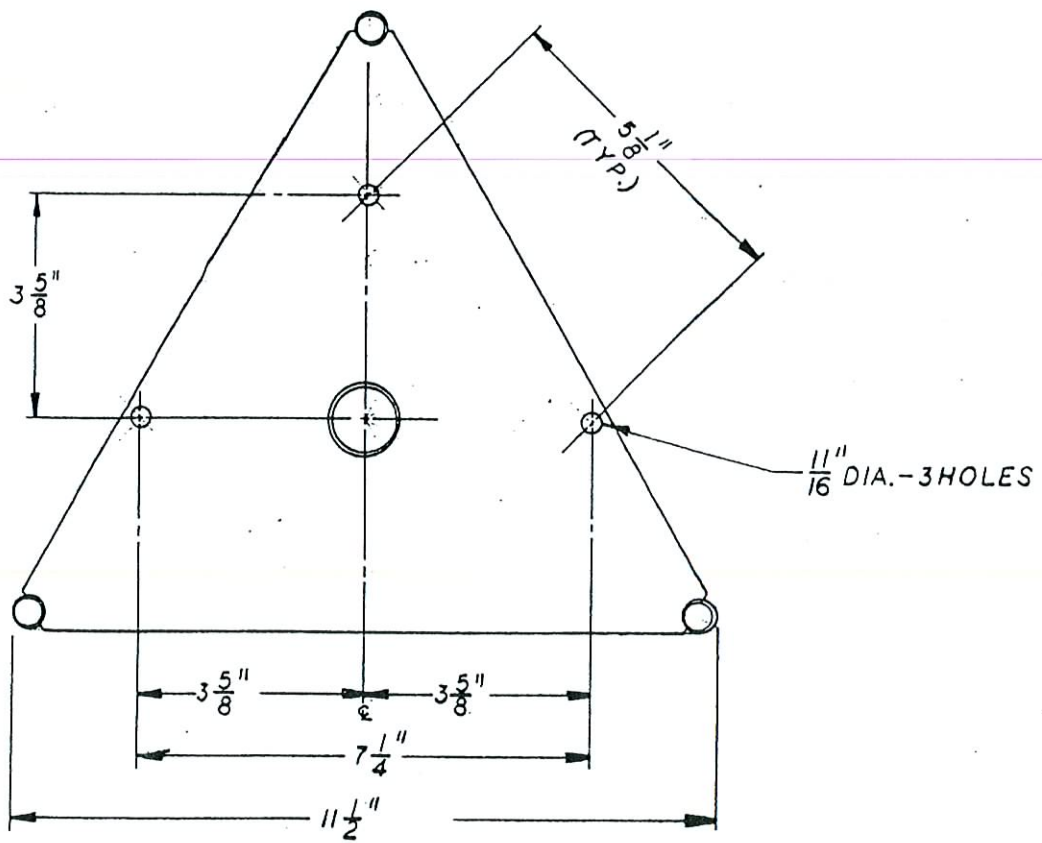
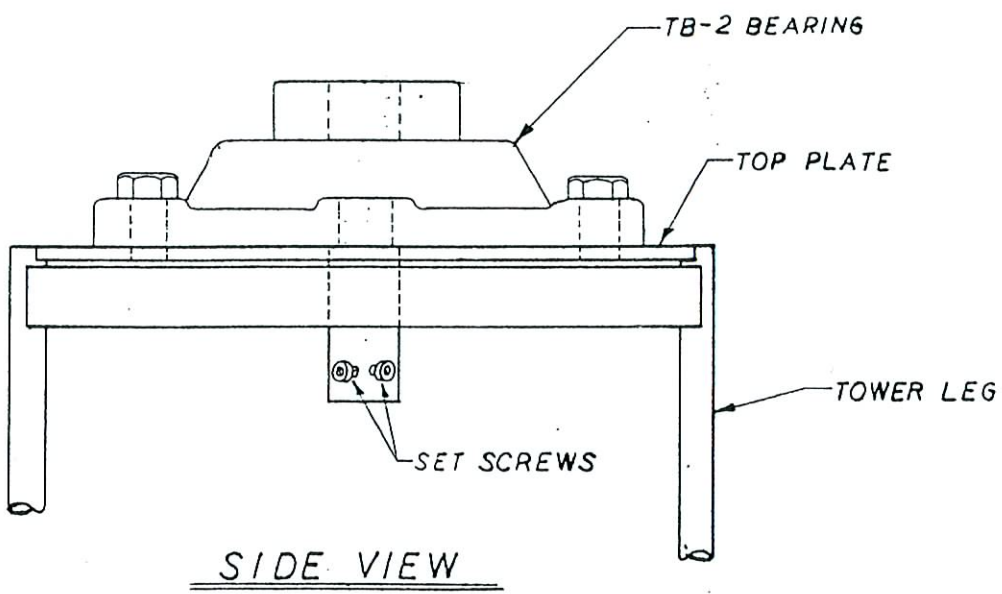

RECEIVED HOLE LAYOUT
MAY 18 2007 TOP VIEW

SUP-21620
REVISED
06/14/07 PC

2" O. D. MAST

TB-2 BEARING (IF USED)

CONTROL CORD TO BE TIED AT UPPER END OF SECTION

TOWER SECTION

CONTROL CORD

CDE HAM II ROTATOR (OR OTHER)

ROTATOR MOUNTING PLATE

ROTATOR MOUNTING PLATE RESTS

RECEIVED
MAY 18 2007

SUP-21620
REVISED
06/14/07 PC

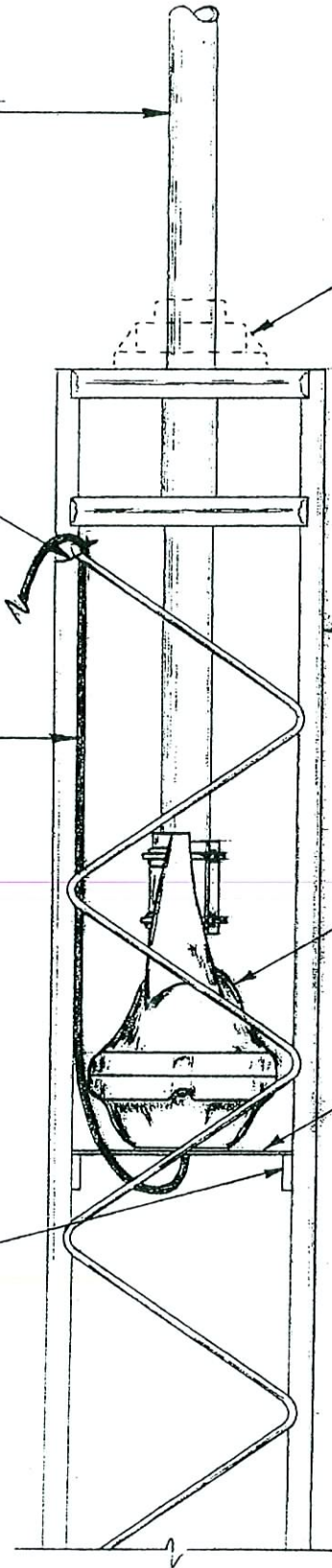

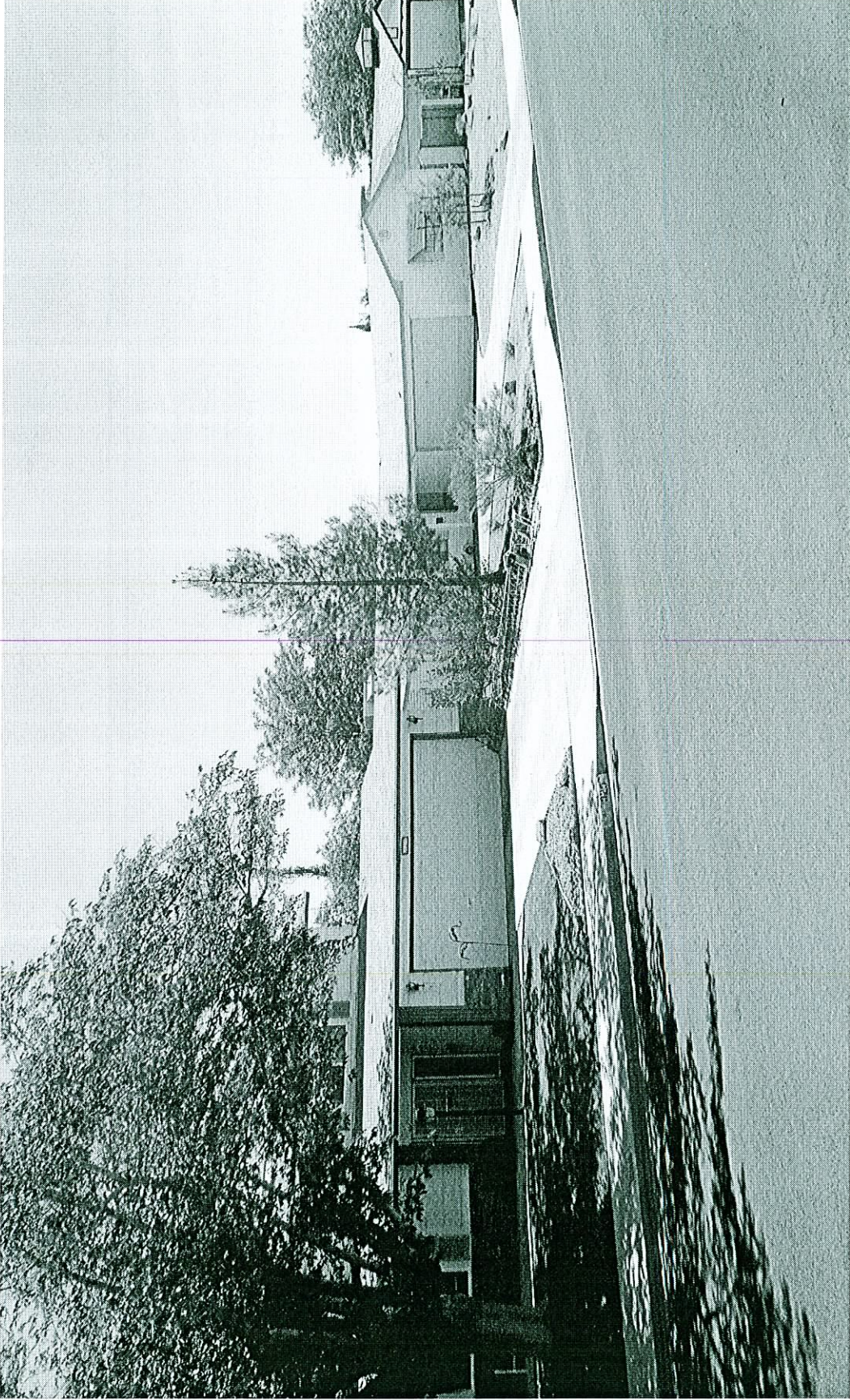

SUP-21620 - APPLICANT/OWNER: TIMOTHY & ALISANDRA VOLZ
325 SANTA FE STREET
JULY 12, 2007 PLANNING COMMISSION

05/23/07



SUP-21620 - APPLICANT/OWNER: TIMOTHY & ALISANDRA VOLZ
325 SANTA FE STREET
JULY 12, 2007 PLANNING COMMISSION

05/23/07