



PLANNING & DEVELOPMENT DEPARTMENT

STATEMENT OF FINANCIAL INTEREST

Case Number: ZON-13889 APN: 139-25-410-017

Name of Property Owner: Jose Sandoval

Name of Applicant: Jose Sandoval

To the best of your knowledge, does the Mayor or any member of the City Council or Planning Commission have any financial interest in this or any other property with the property owner, applicant, the property owner or applicant's general or limited partners, or an officer of their corporation or limited liability company?

Yes No

If yes, please indicate the member of the City Council or Planning Commission who is involved and list the name(s) of the person or persons with whom the City Official holds an interest. Also list the Assessor's Parcel Number if the property in which the interest is held is different from the case parcel.

City Official: _____

Partner(s): _____

APN _____

Signature of Property Owner: J. Sandoval

Print Name: Jose Sandoval

Subscribed and sworn before me

This 30TH day of MAY, 2006

Danny R. Wall
Notary Public in and for said County and State

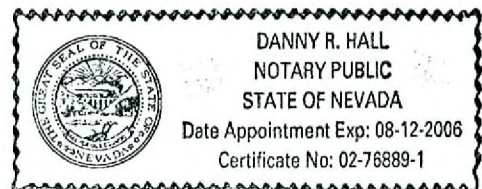

RECEIVED

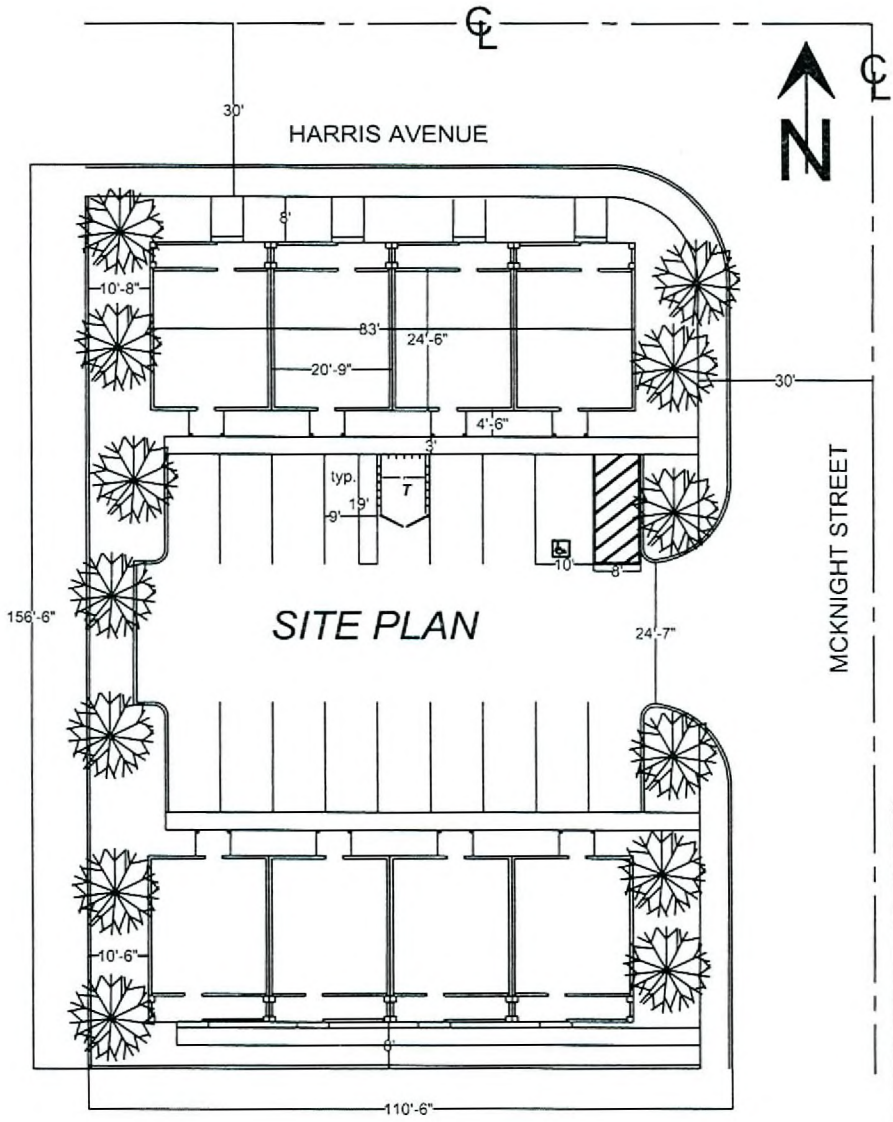

LANDSCAPE SCHEDULE

-  20' DESERT TREE -- MESQUITE, PALO VERDE, DESERT WILLOW
-  PALM TREE
-  DESERT SHRUBS -- LANTANA, RANGER SAGES, CASSIAS, RUSSIAN SAGE, VARIOUS PENSTEMENS
-  GROUND COVERS -- VARIOUS
-  COLORED GRAVELS RANDOMLY
-  OVERCAST WITH MINUS 6" ROCKS

HARRIS MCKNIGHT CORNER
 2750 HARRIS AVENUE
 APN 139-25-410-017
 SCALE 1/16"=1'-0"

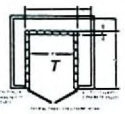

TYPICAL TRASH ENCLOSURE

PARKING ANALYSIS

8 TWO BEDROOM UNITS REQUIRES 16 PARKING SPACES
 16 SPACES ARE SHOWN INCLUDES ONE VAN ACCESSIBLE HANDICAP SPACE

ASSESSOR'S PARCEL NUMBER
 139-25-410-017

LOT COVERAGE ANALYSIS

TOTAL FOOTPRINT ALL UNITS = 4,067 SF
 TOTAL BLACKTOP = 5,600 SF
 TOTAL LOT SIZE = 15,794 SF
 TOTAL LANDSCAPE AREA = 6,127 SF
 FOOTPRINT TO LOT SIZE RATIO = 1 : 4
 PERCENTAGE OF LOT COVERAGE = 26%

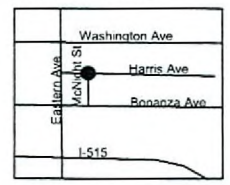

VICINITY MAP
 no scale

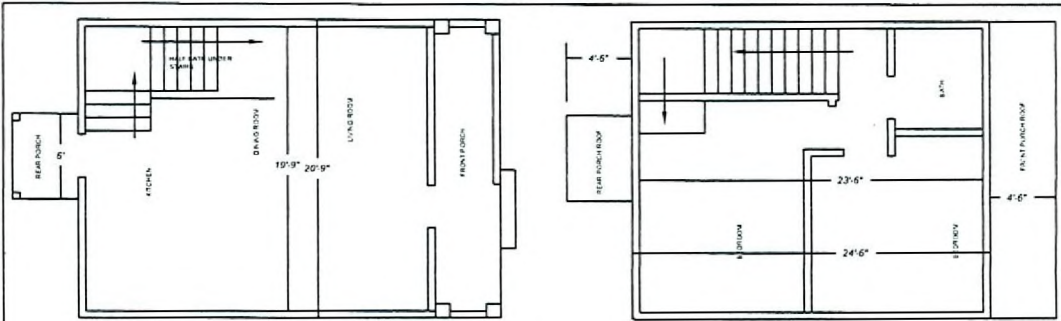

FIRST FLOOR PLAN
 450 SF

SCALE 1/8" = 1'-0"

SECOND FLOOR PLAN
 450 SF

GPA-13888 ZON-13889
VAR-13888 SDR-13886
07-13-06 PC

RECEIVED

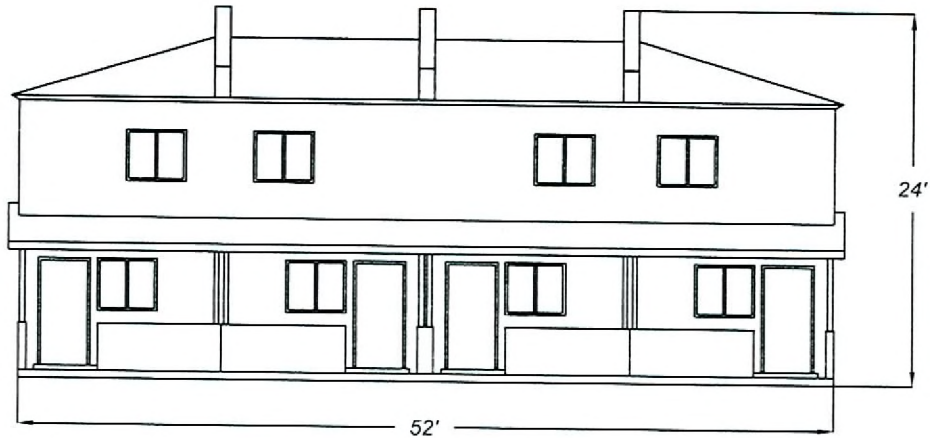

REAR ELEVATION

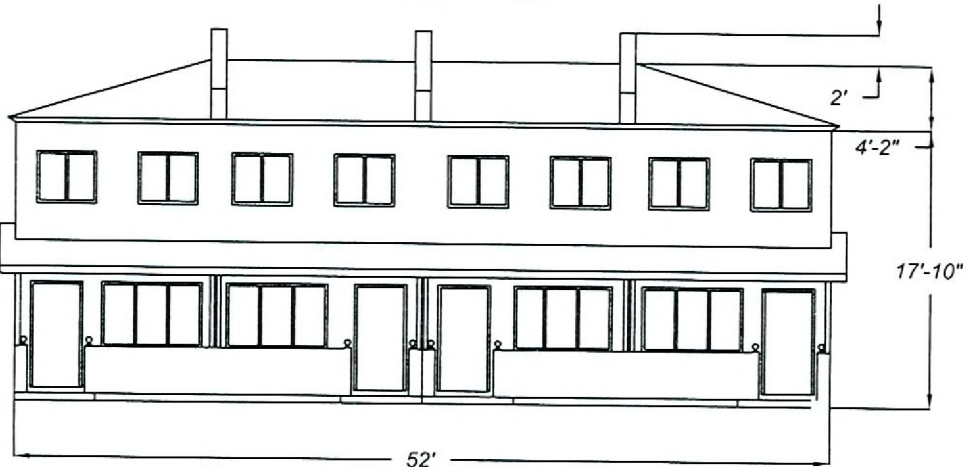

FRONT ELEVATION

TWO STORY TOWNHOUSE
SIDE ELEVATION (all)

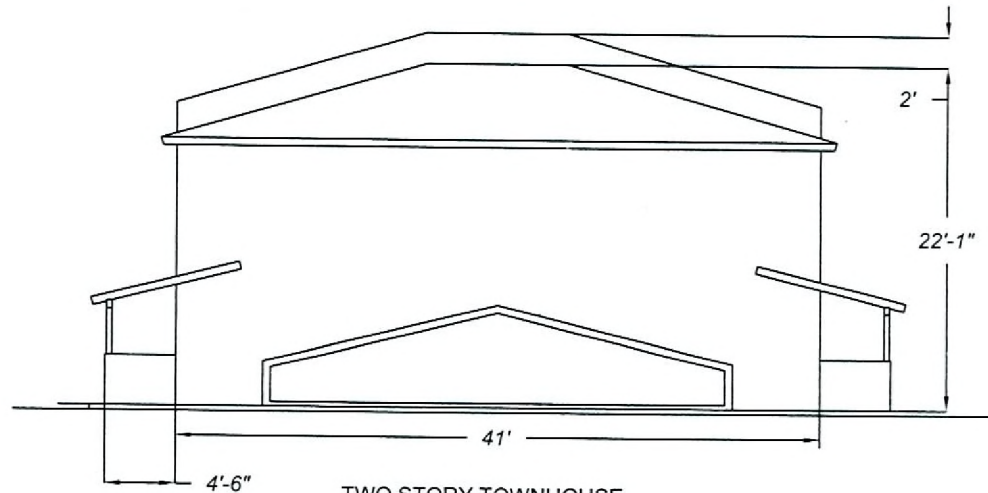
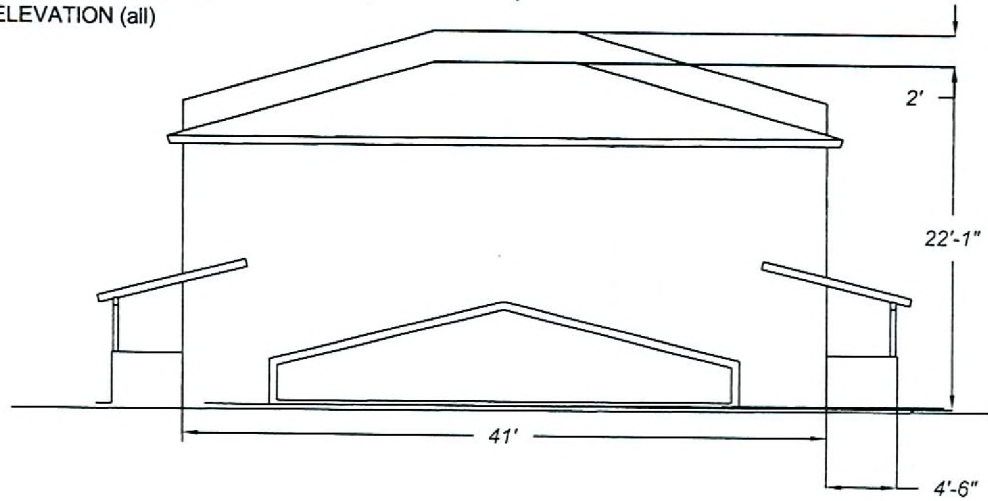

TWO STORY TOWNHOUSE
SIDE ELEVATION (all)

GPA-13888 ZON-13889
VAR-13888 SDR-13886
07-13-06 PC

RECEIVED