

# EXHIBIT "A"

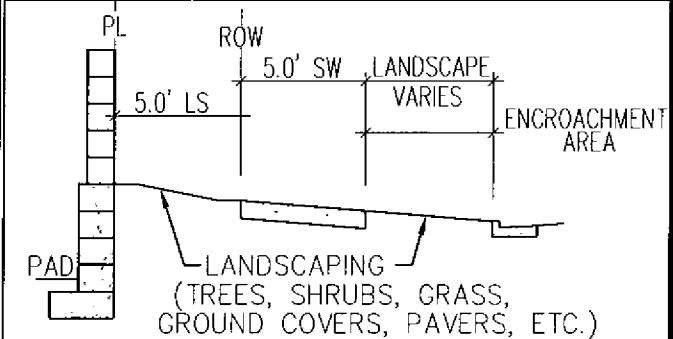
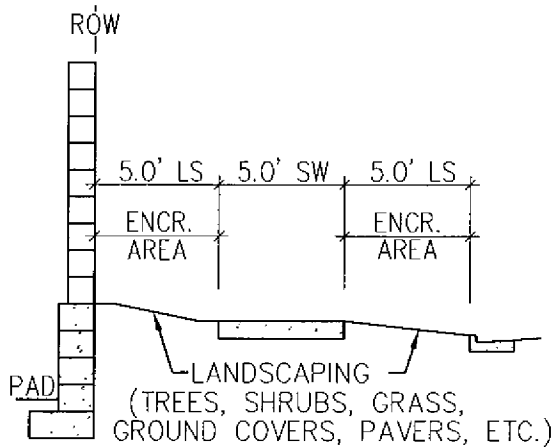
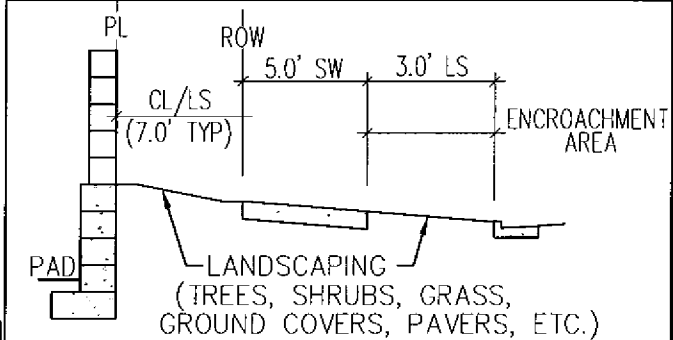
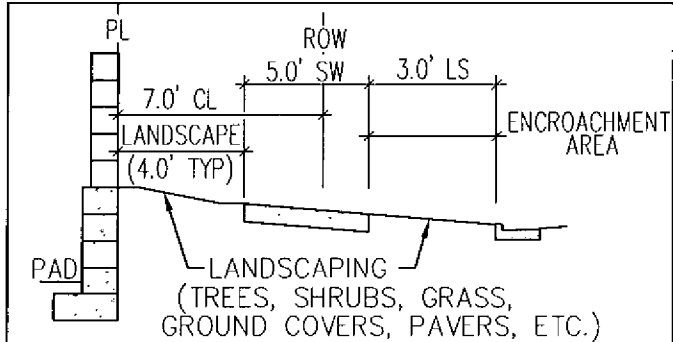
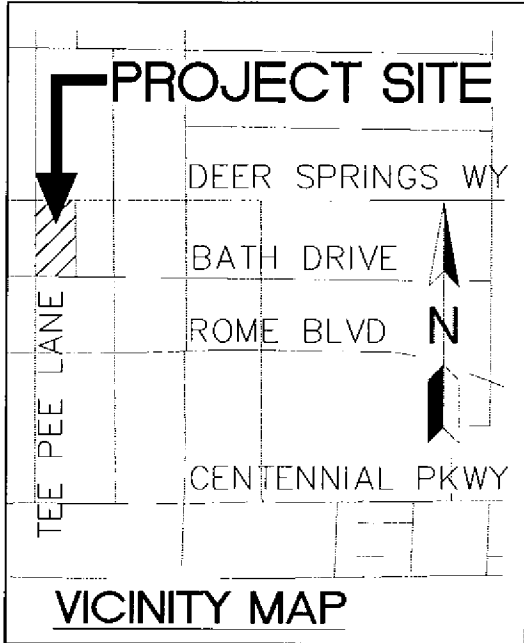

**S-I-G** SLATER HANIFAN GROUP  
CONSULTING ENGINEERS & PLANNERS

PARDEE HOMES  
TOWN CENTER 44/50 No. 2  
ENCROACHMENT EXHIBIT

DATE: 10/19/06  
DRAFTER: EHK  
DESIGNER: JDP  
CHECKED: TJS

PROJECT NO.  
PAR0302.009  
S-1  
SHEET 1 OF 2