

1 PROPERTY LINE FOOTING @ COL. LINE H-3 @ SCALE 3/4"=1'-0"

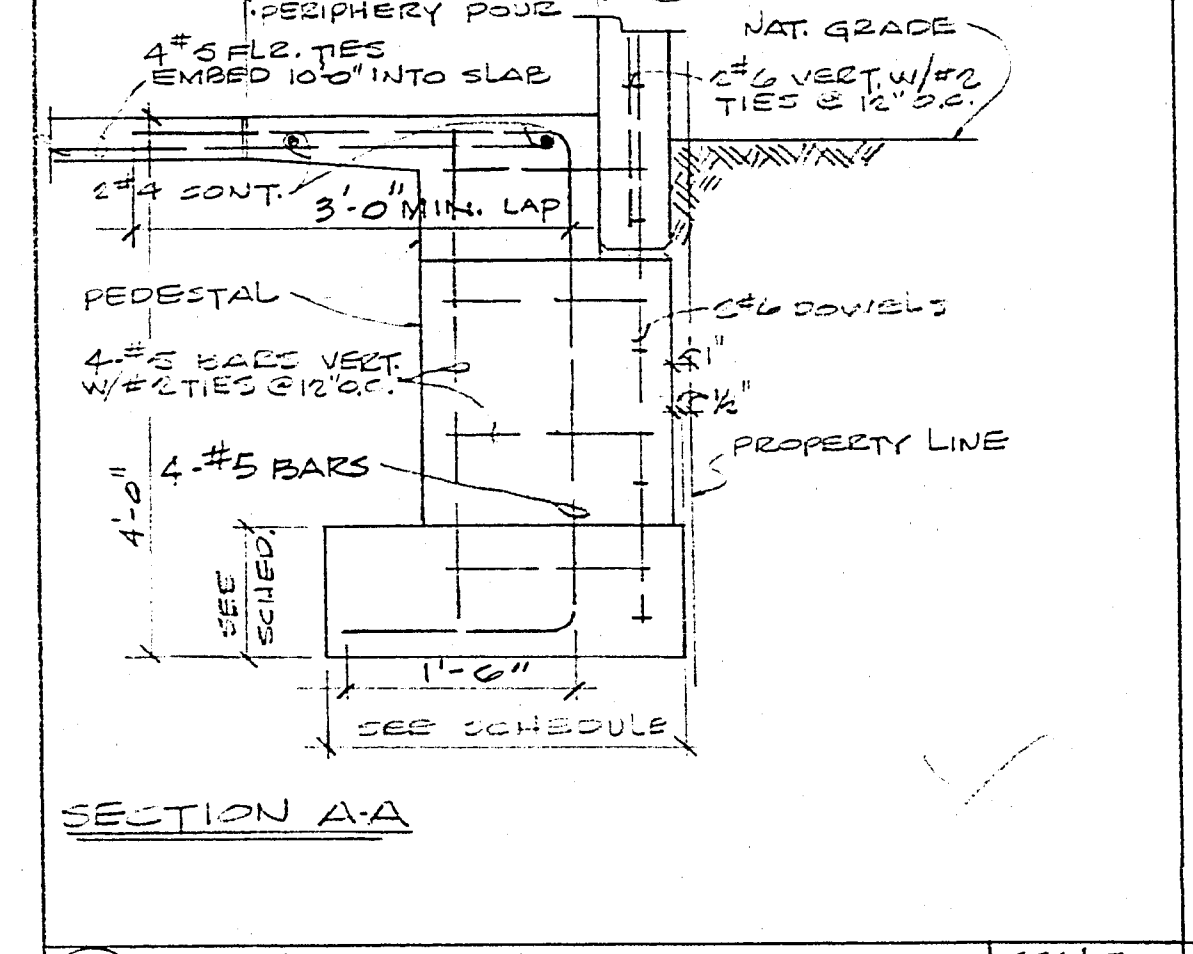

2 PROPERTY LINE FOOTING @ COL. LINE H-1 @ SCALE 3/4"=1'-0"

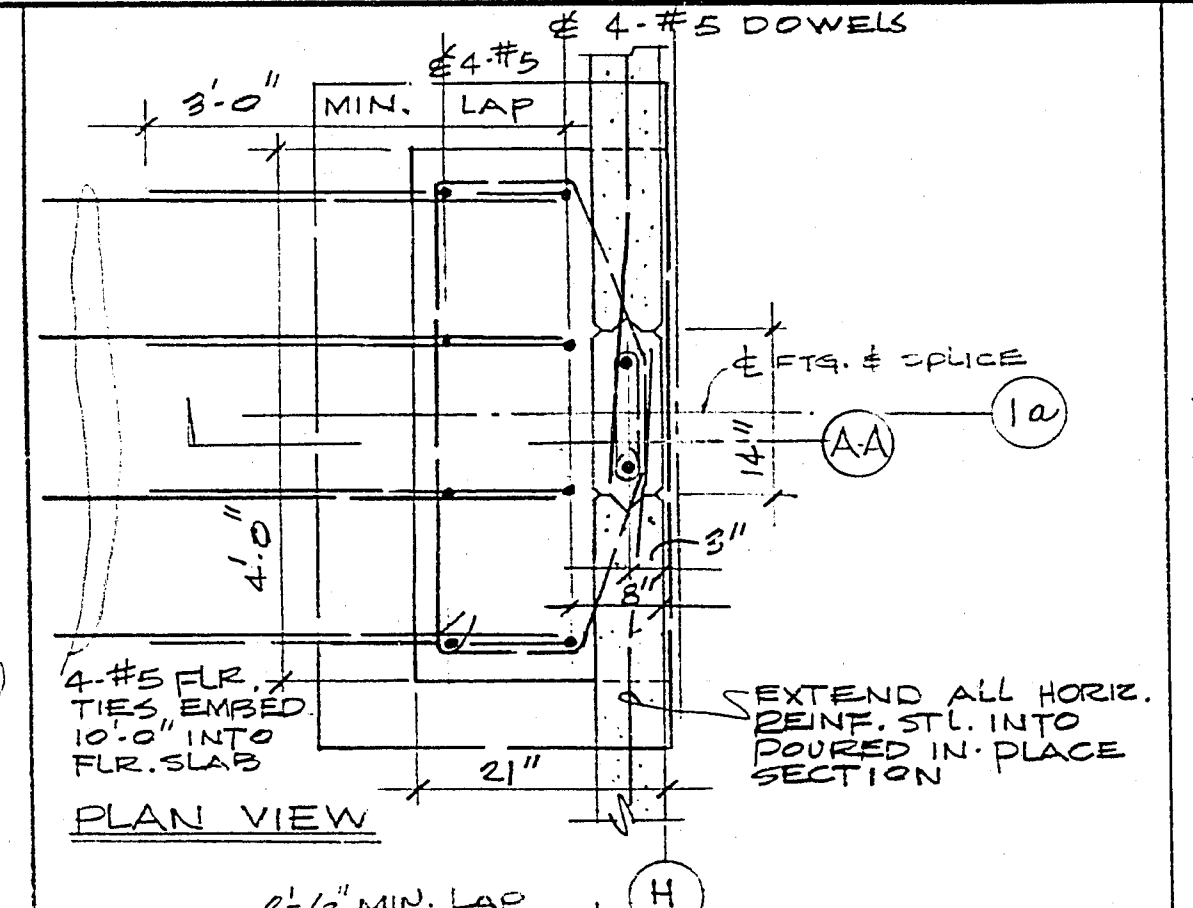
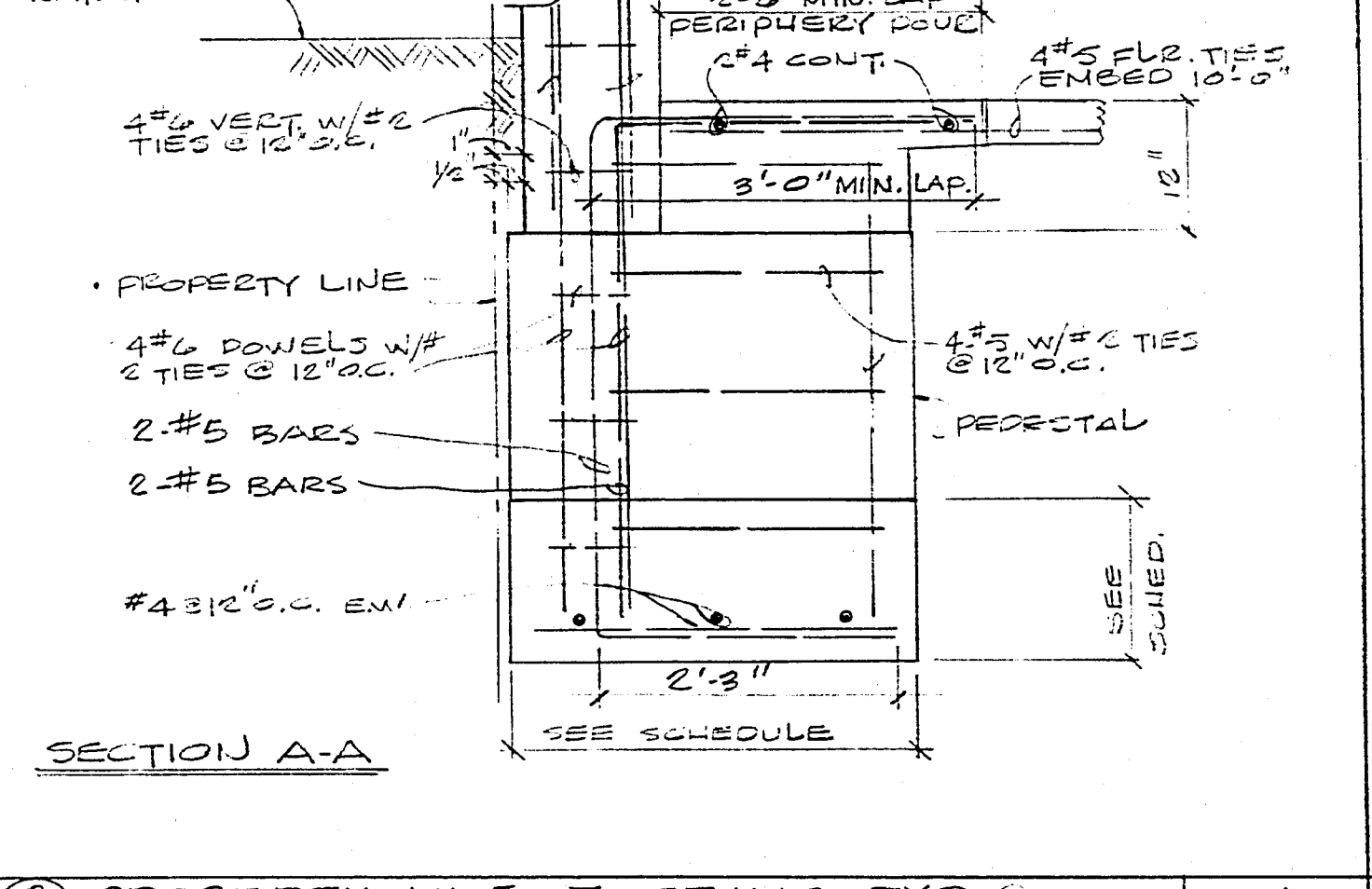
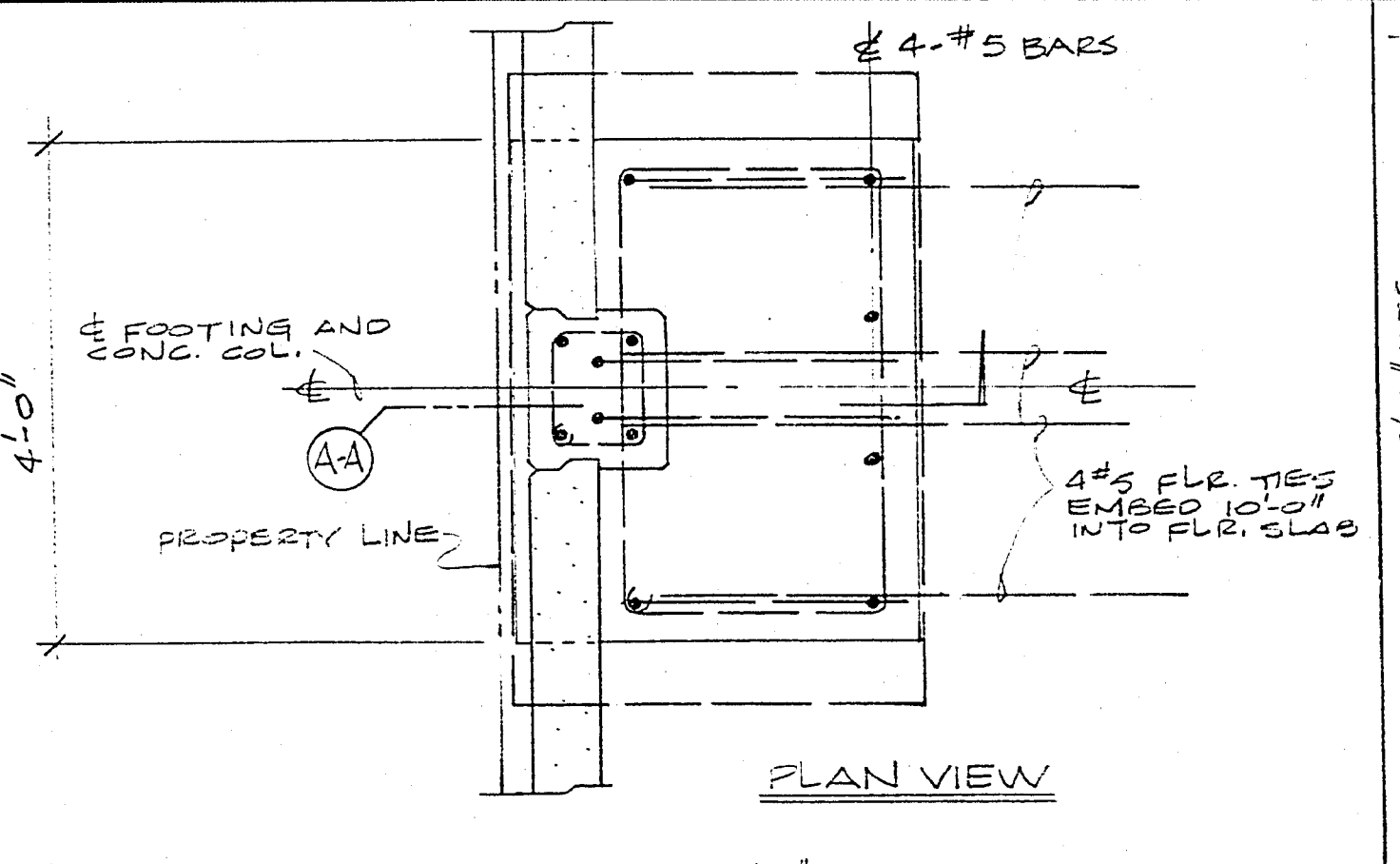

3 PROPERTY LINE FOOTING TYP. @ COL. LINE F-1 @ SCALE 3/4"=1'-0"

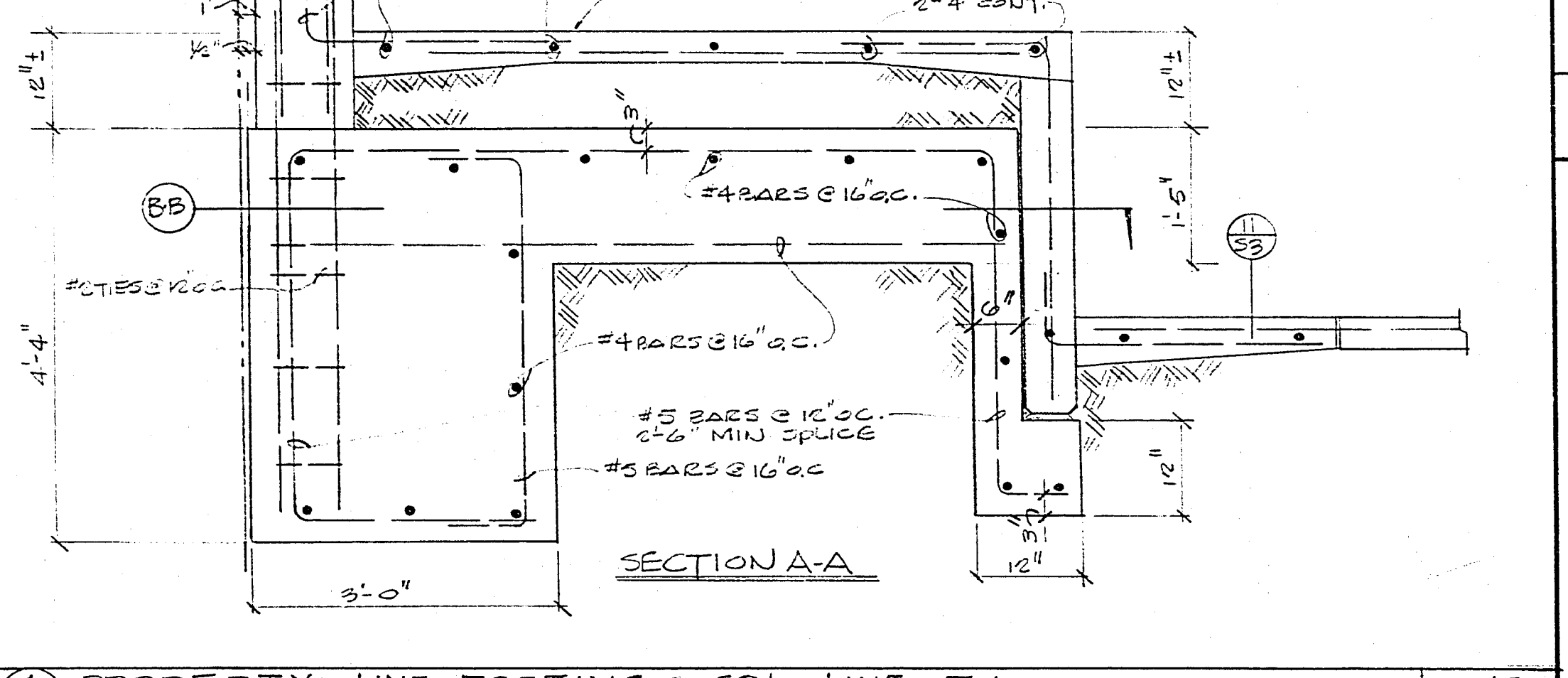
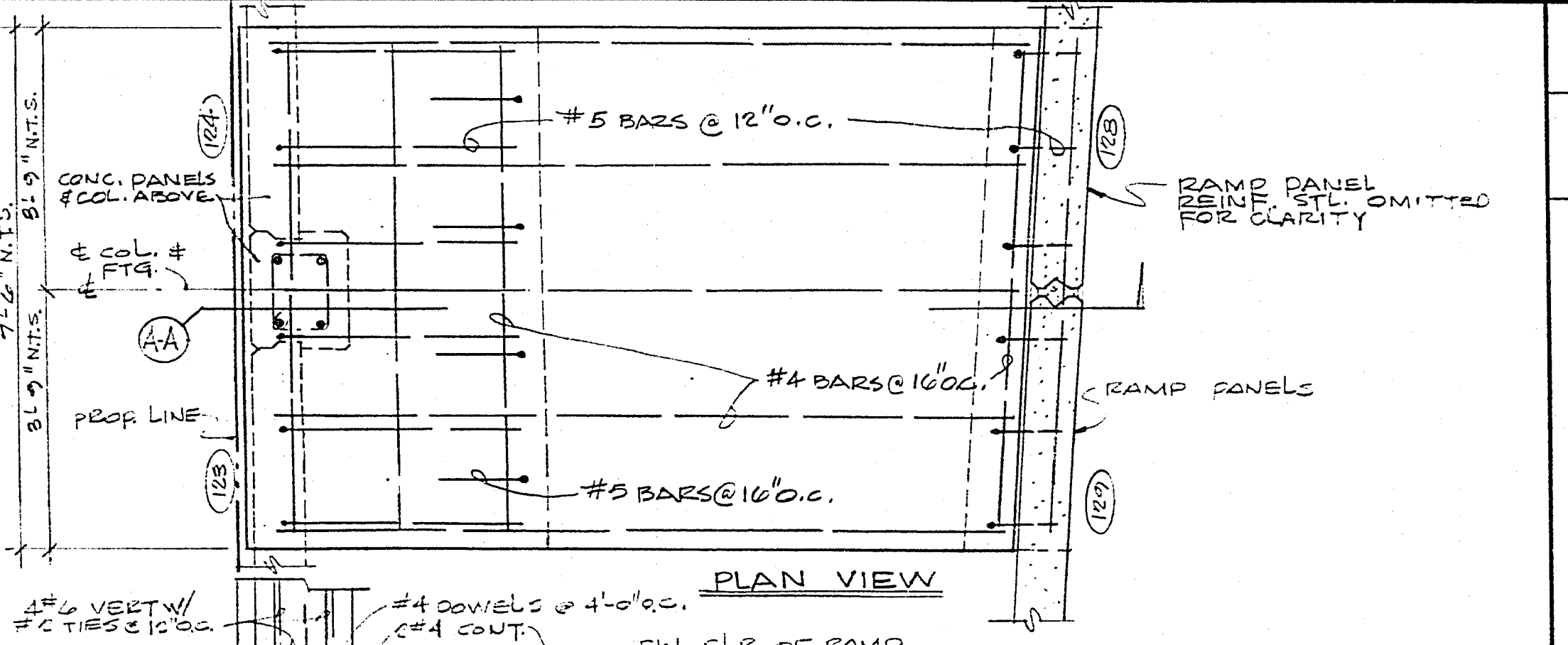

4 PROPERTY LINE FOOTING @ COL. LINE F-1 @ SCALE 3/4"=1'-0"

WHOLESALE RETAIL DISTRIBUTION CENTER
 SMART AND FINA. IRIS CO.
 NORTH MAIN ST. LAS VEGAS, NEVADA

DATE: 12/20/70
 BY: J. H. Macdonald
 CHECKED: J. H. Macdonald
 APPROVED: J. H. Macdonald

THESE DRAWINGS ARE THE PROPERTY OF JACK H. MACDONALD ARCHITECTS AND ENGINEERS. NO PART OF THESE DRAWINGS IS TO BE REPRODUCED OR TRANSMITTED IN ANY FORM OR BY ANY MEANS, ELECTRONIC OR MECHANICAL, WITHOUT THE WRITTEN CONSENT OF JACK H. MACDONALD ARCHITECTS AND ENGINEERS.

JACK H. MACDONALD
 ARCHITECTS AND ENGINEERS
 321 S. SAN VICENTE BLVD. LOS ANGELES 90048 272-3131

SHEET NO. 5

521-228