

City of Las Vegas, Nevada
Office of Architectural Services and Project Control
 Don J. Saylor A.I.P. Deputy City Manager

WEST SIDE SCHOOL RENOVATION
 DETAILS A AND C, DETAILS
 Design By: J. J. JACOBI Date: 8-82
 Drawn By: J. J. JACOBI Date: 8-82
 Division: TECHNICAL SERVICES Scale: AS SHOWN

Sheet No. 513-82
 of 57
 11/15/82

PRESERVE ONLY
 (NO CONSTRUCTION NECESSARY) STRIP ALL WOOD MEMBERS OF EXISTING PAINT & PRIMER. FILL ALL GUTTS AND HOLES WITH WOOD PUTTY AND SAND SMOOTH. PAINT ALL EXPOSED SURFACES WITH 1 COAT OF PRIMER AND 2 COATS OF PAINT AS PER SPECIFICATIONS.

RECONSTRUCT
 THIS PORTION OF THE STRUCTURE WILL REQUIRE COMPLETE RECONSTRUCTION, FINISHED TO BE IDENTICAL TO ORIGINAL CONSTRUCTION AS SHOWN ON THIS SHEET AS WELL AS SHEETS 38 & 39. WOOD USED MUST BE AS CLOSE TO ORIGINAL SPECIES & GRADE AS POSSIBLE. SAND SMOOTH & FINISH ALL EXPOSED WOOD SURFACES WITH 1 COAT OF PRIMER AND 2 COATS OF PAINT AS PER SPECIFICATIONS.

GLAZING
 GLAZE ALL OPENINGS WITH 3/16" THICK GENERAL ELECTRIC MARGAARD LEXAN, UNLESS NOTED OTHERWISE. REMOVE ALL EXISTING QUARTER ROUND AND REPLACE WITH NEWLY CONSTRUCTED MATERIAL AS PER THIS SHEET & SHEETS 38 & 39.

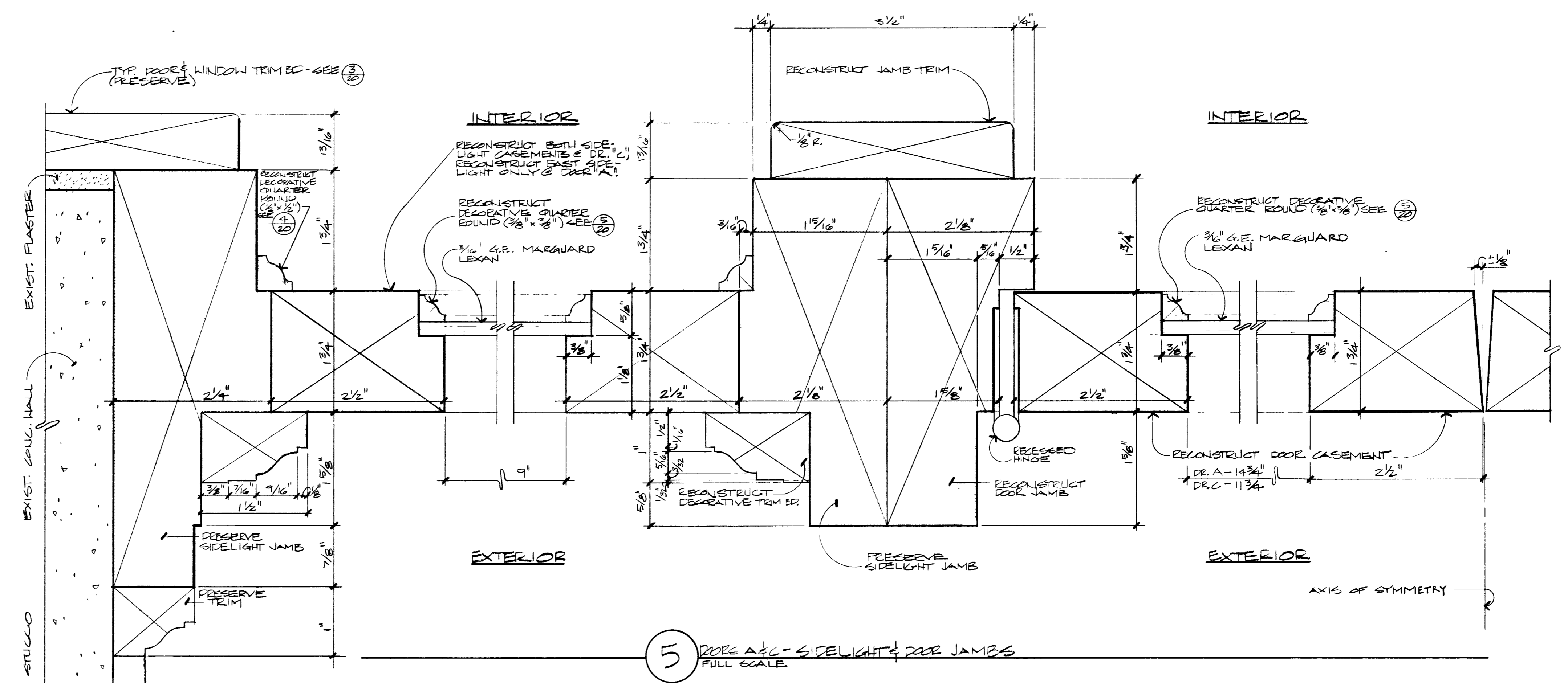
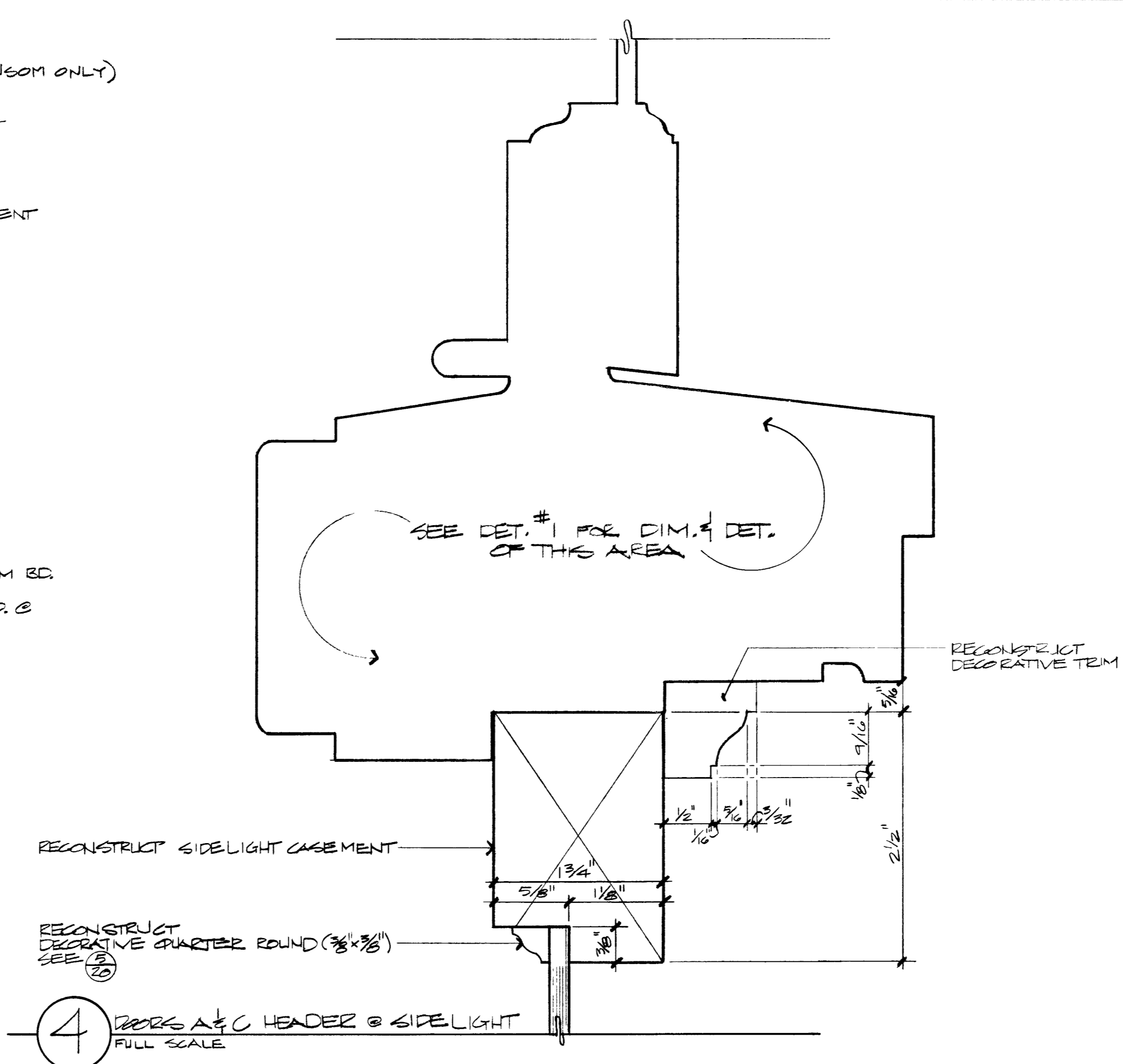
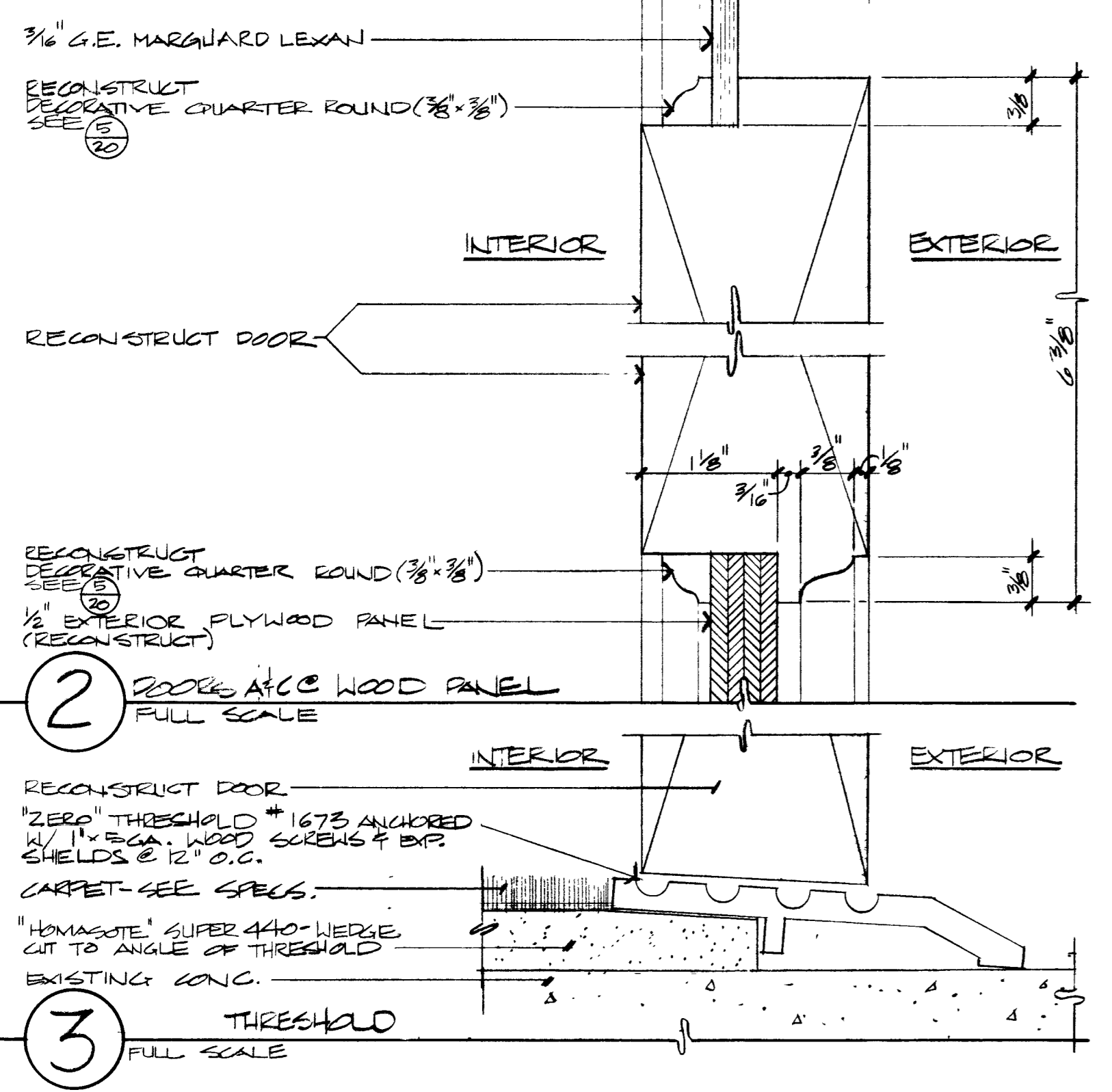
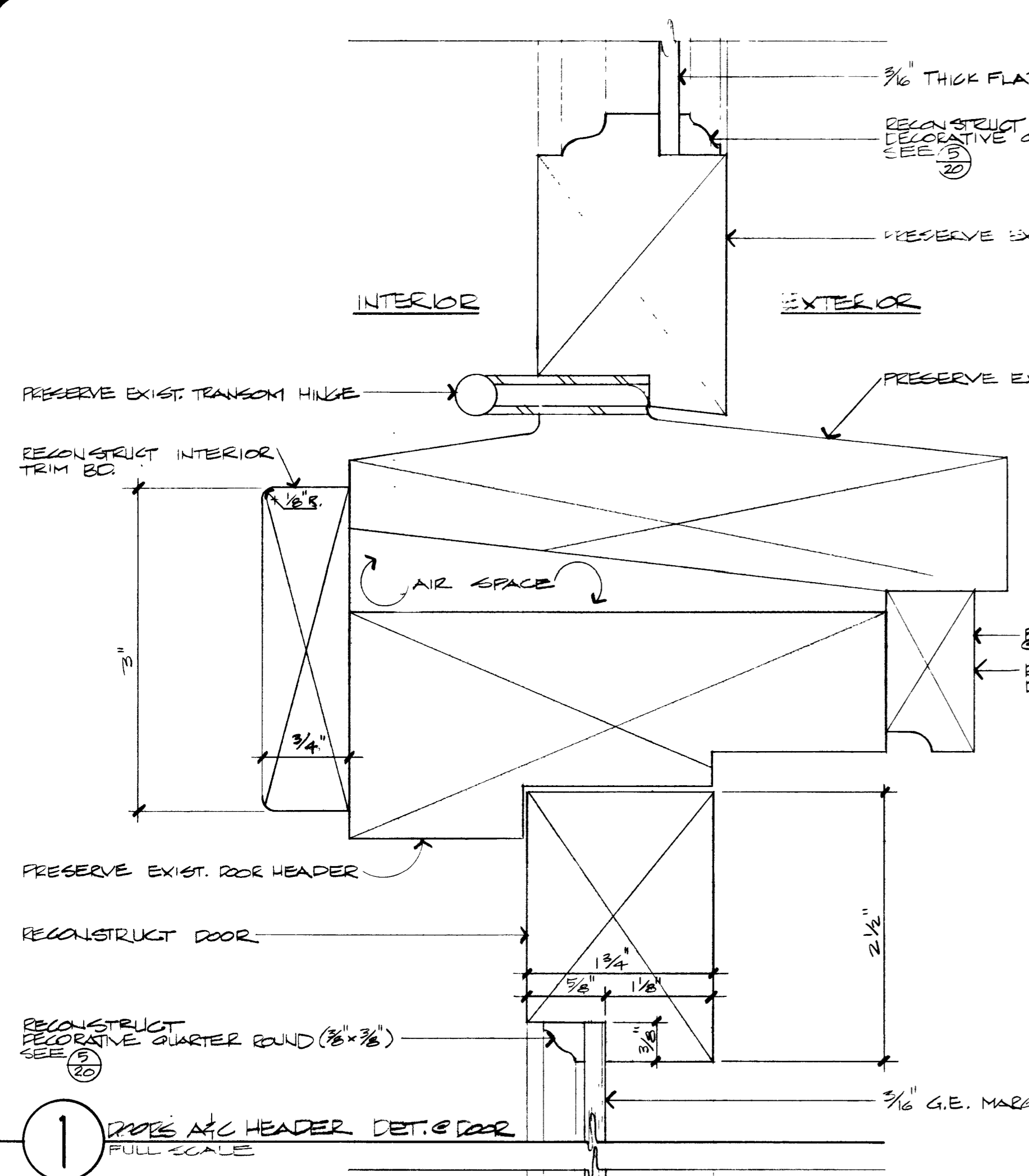

CONTRACT EXPIRES NOV 30 1982

Charles E. Saylor
 11/19/82

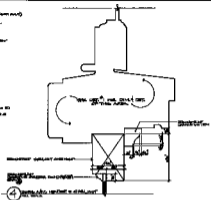
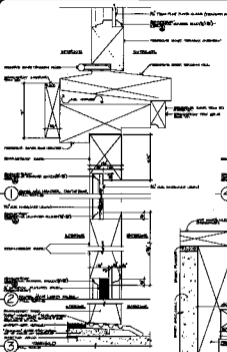

SECTION	SECTION
SECTION	SECTION
SECTION	SECTION

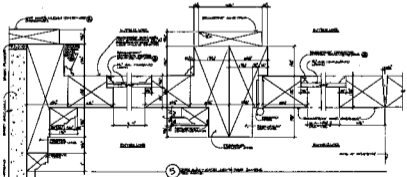

City of Los Angeles, Nevada
 Office of Planning and
 Economic Development
 100 S. Main St., Suite 100
 Las Vegas, NV 89101

PROJECT NO.	DATE
DESIGNED BY	CHECKED BY
DRAWN BY	APPROVED BY
SCALE	DATE

