

**TYPICAL GARDEN VILLA LOT
DRAINAGE & GRADING**

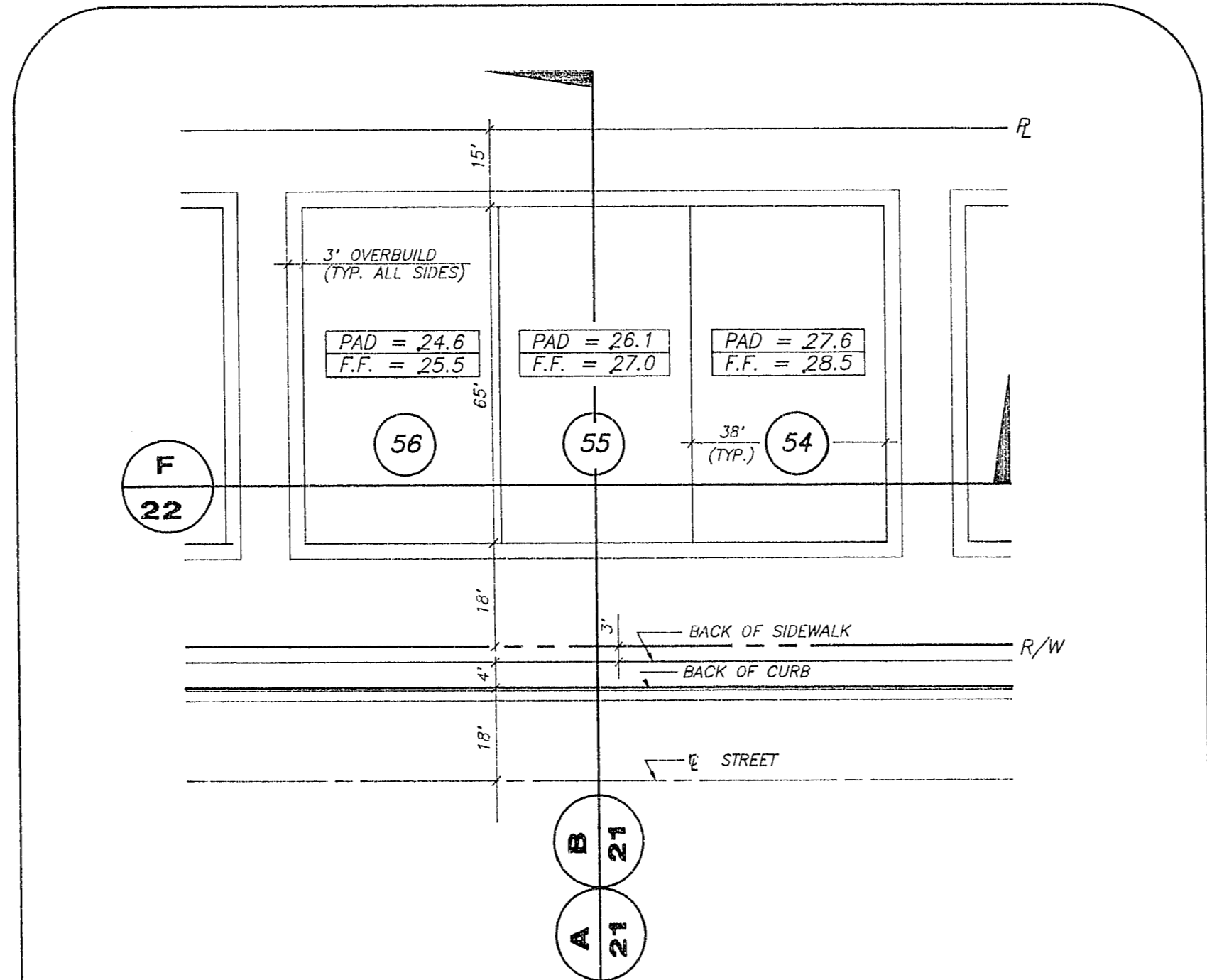

ROUGH GRADING PLAN

GARDEN VILLAS NOT TO SCALE

**1
22**

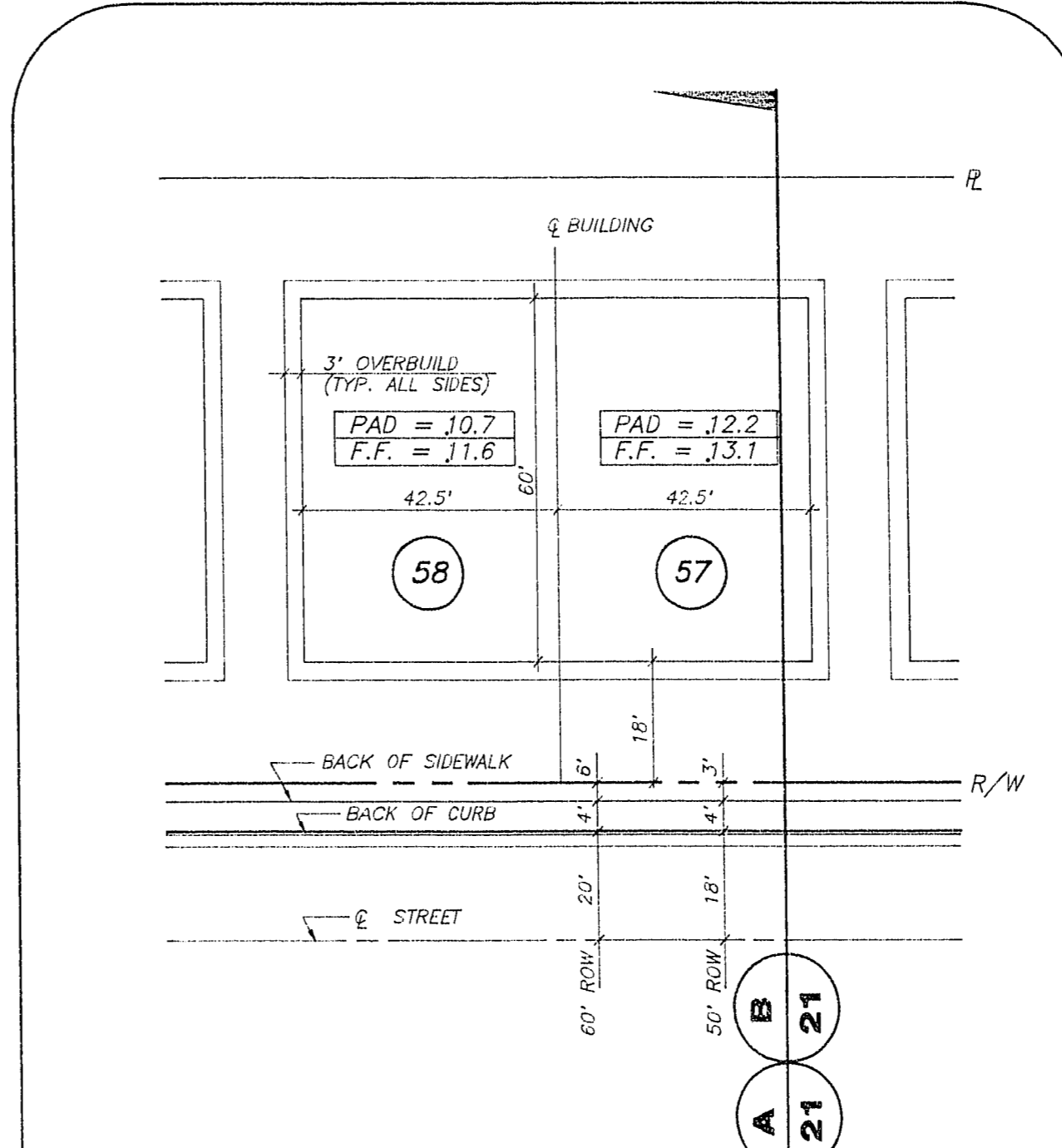

ROUGH GRADING PLAN

DUPLEX NOT TO SCALE

**2
22**

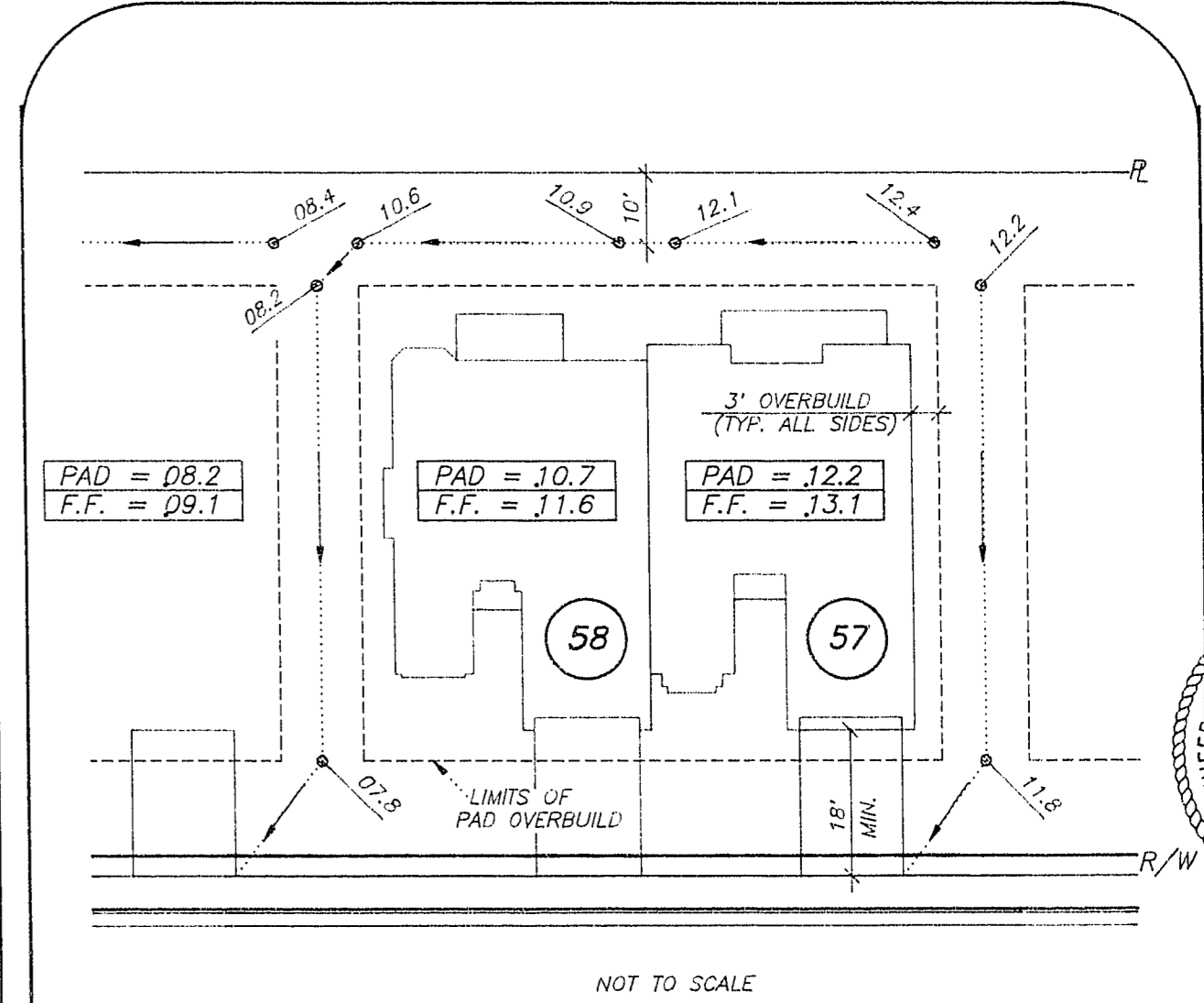

**TYPICAL DUPLEX LOT
DRAINAGE & GRADING**

**Call
before you
Dig.**
1-800-227-2600
REGULATORY SERVICE (USA)

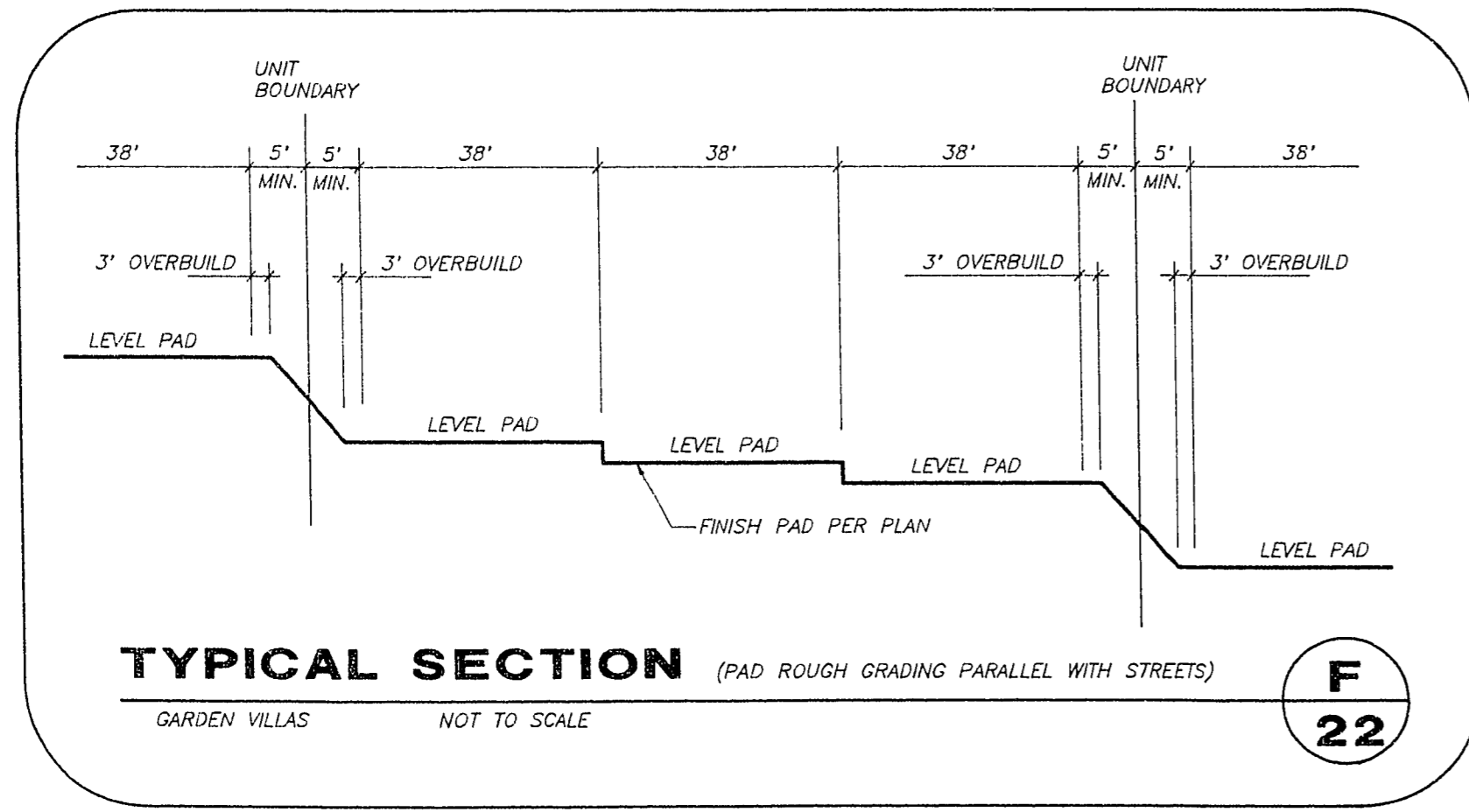

TYPICAL SECTION (PAD ROUGH GRADING PARALLEL WITH STREETS)

GARDEN VILLAS NOT TO SCALE

**F
22**

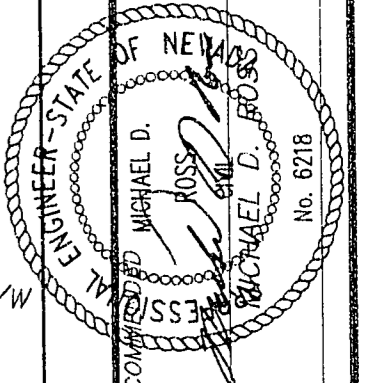

REV.	DATE	DESCRIPTION	C.L.K.	DATE

G. C. WALLACE, INC.
Engineering/Architecture
1555 SOUTH RAINBOW BLVD., LAS VEGAS, NEVADA 89102

DEL WEBB COMMUNITIES, INC.
SUN CITY LAS VEGAS UNIT NO. 39
GRADING DETAILS II

SHEET
22
OF 22 SHEETS

JOB NO. 701.168 PLOTTER: 06/09/90 10:35 am

10-9-63 1074-441-39