

DATE: 9/11/12
 DATE LAST APP. DATE (SEE APP.)
 DATE REVISION
 DESCRIPTION

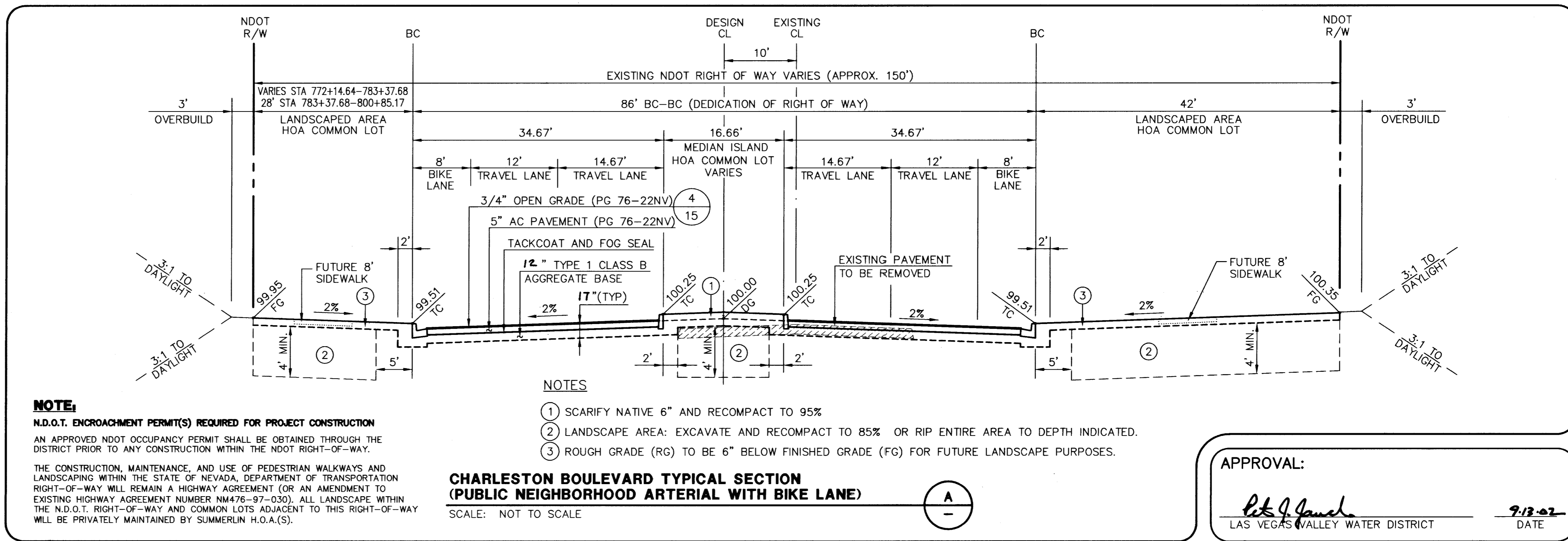
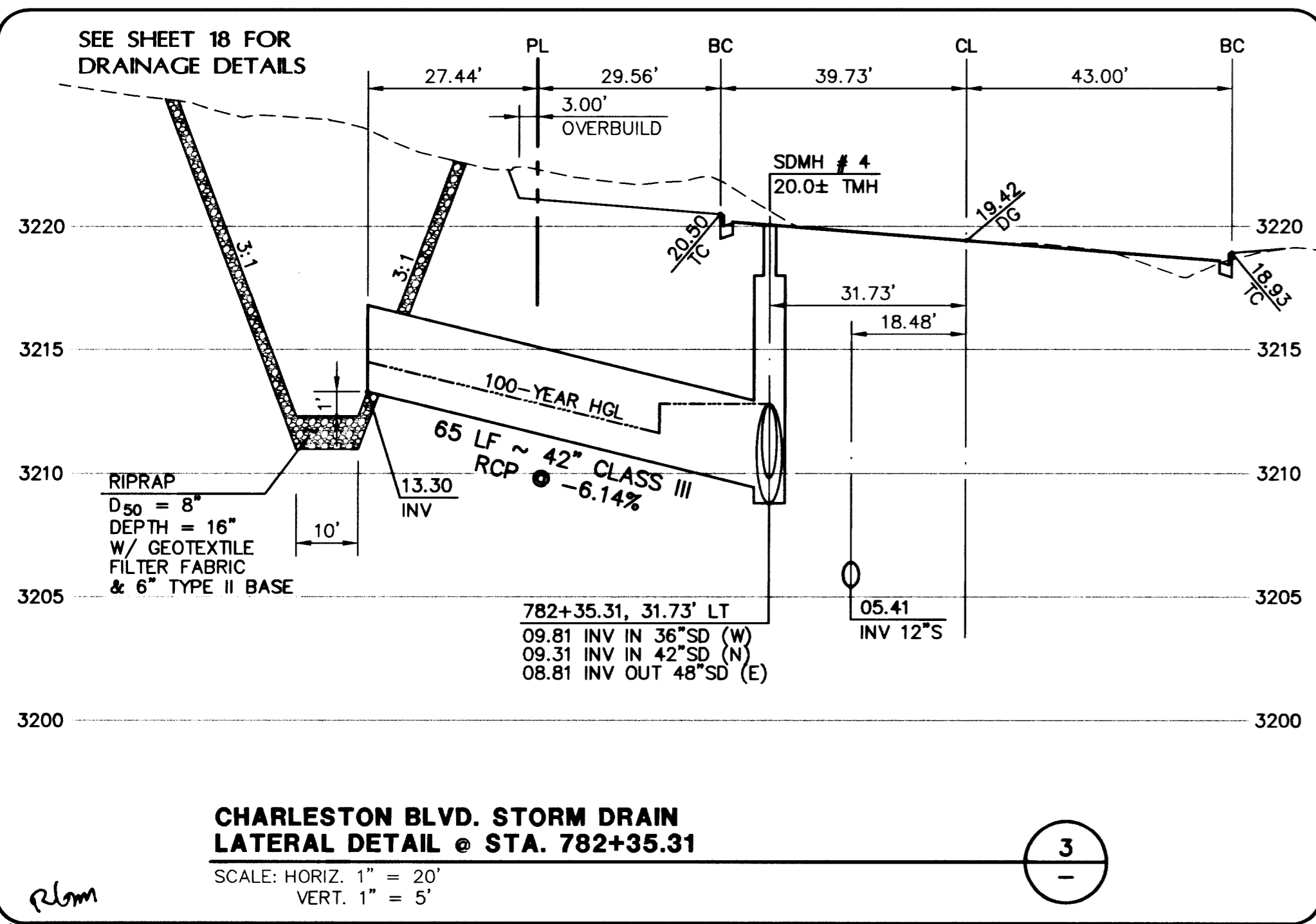
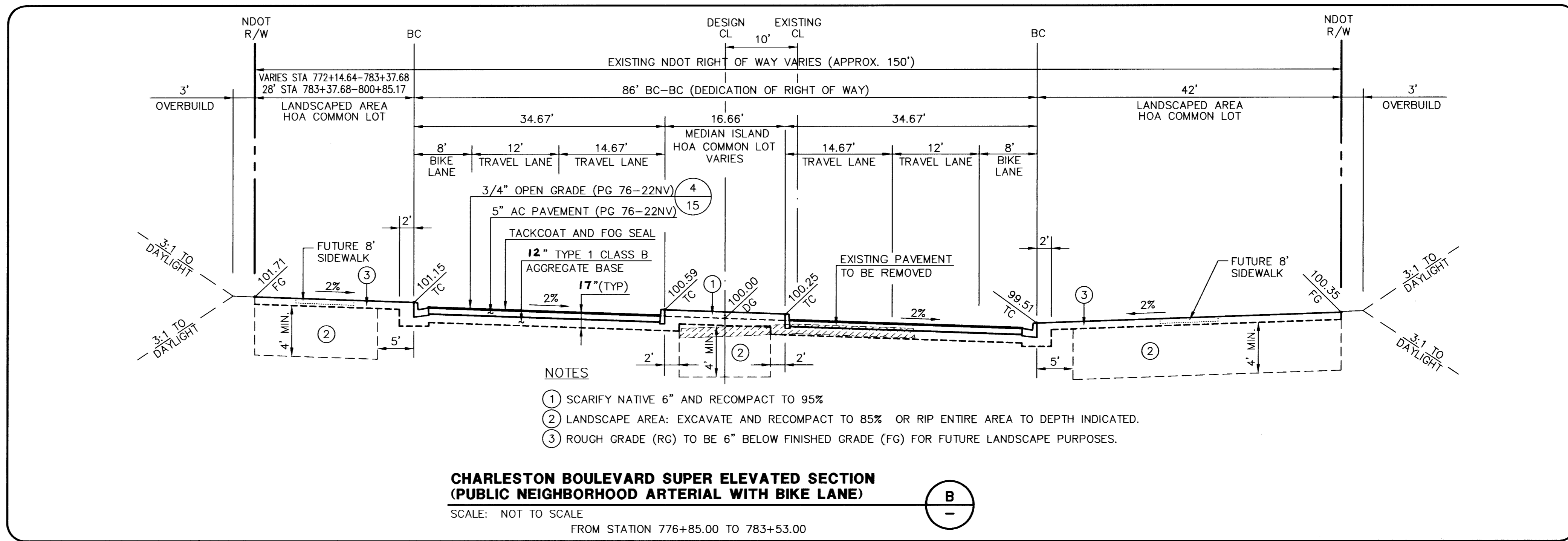
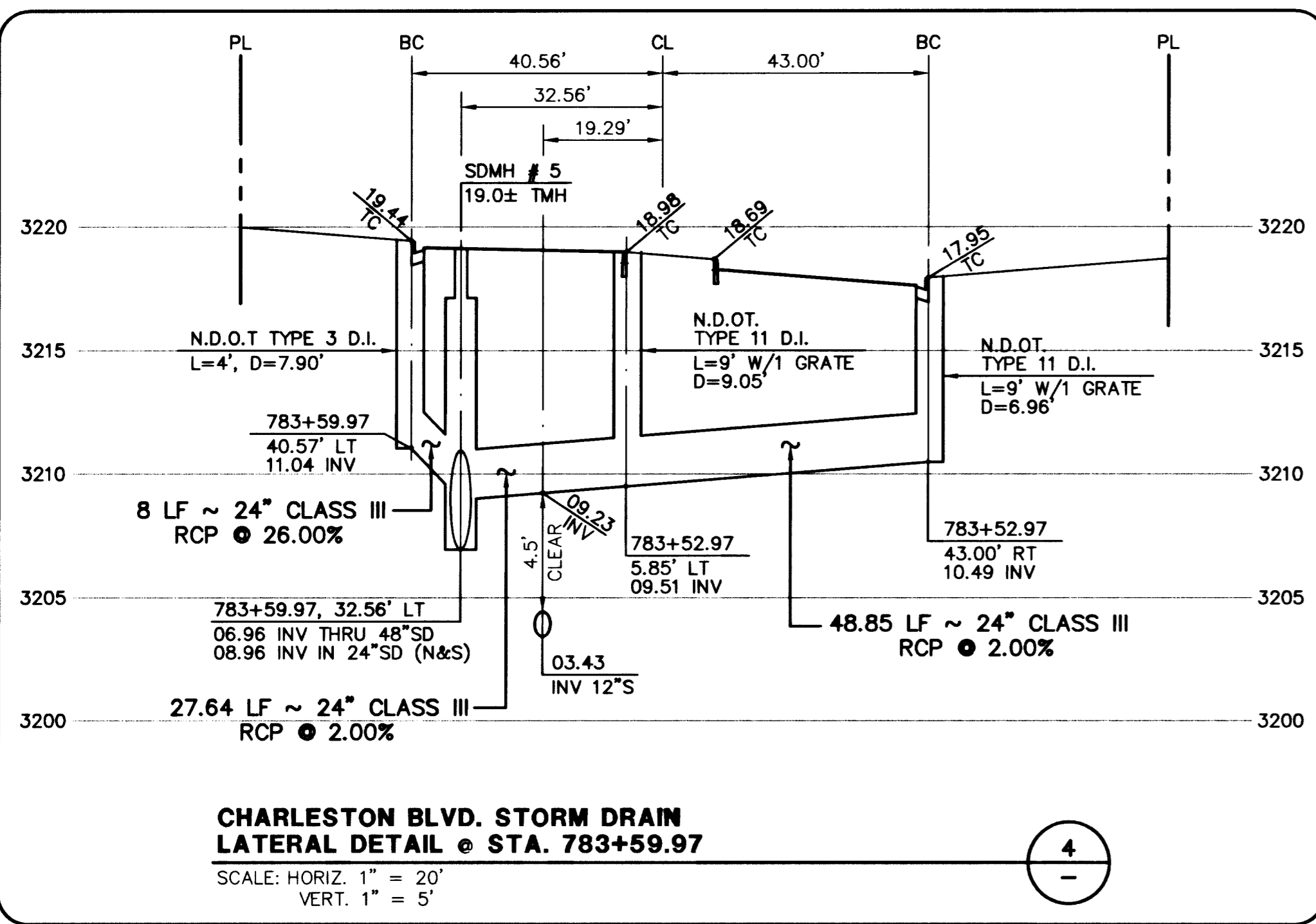
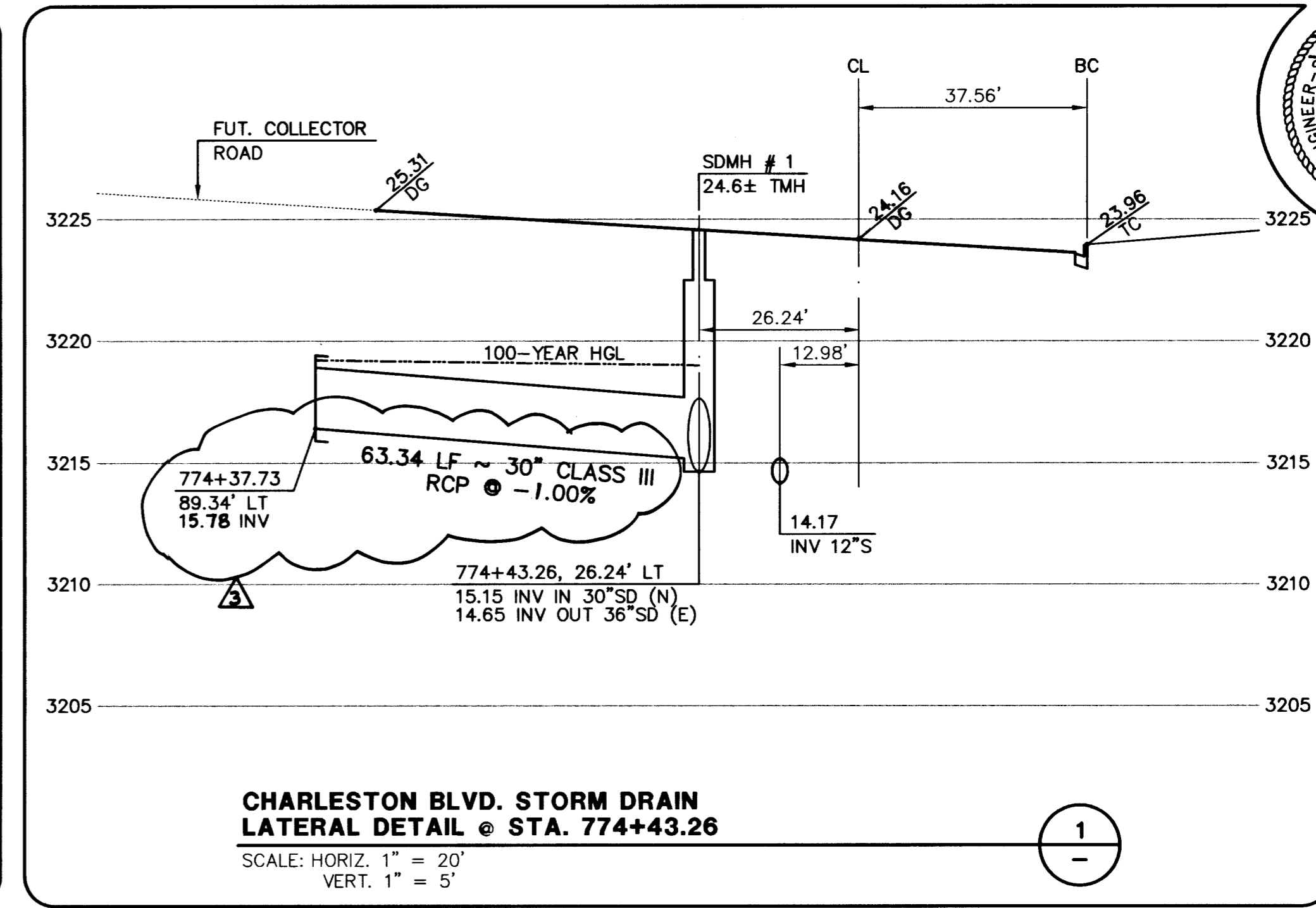
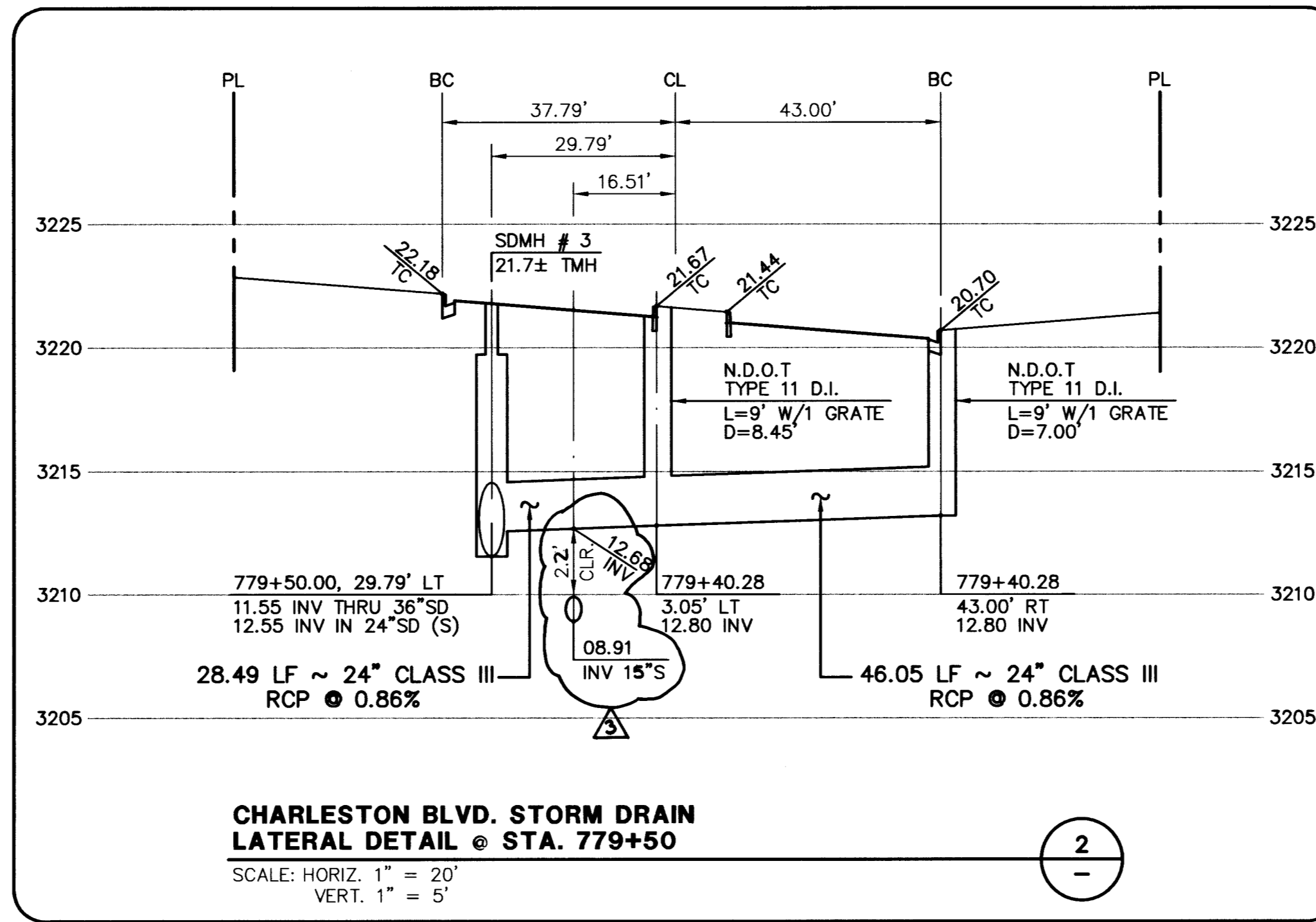
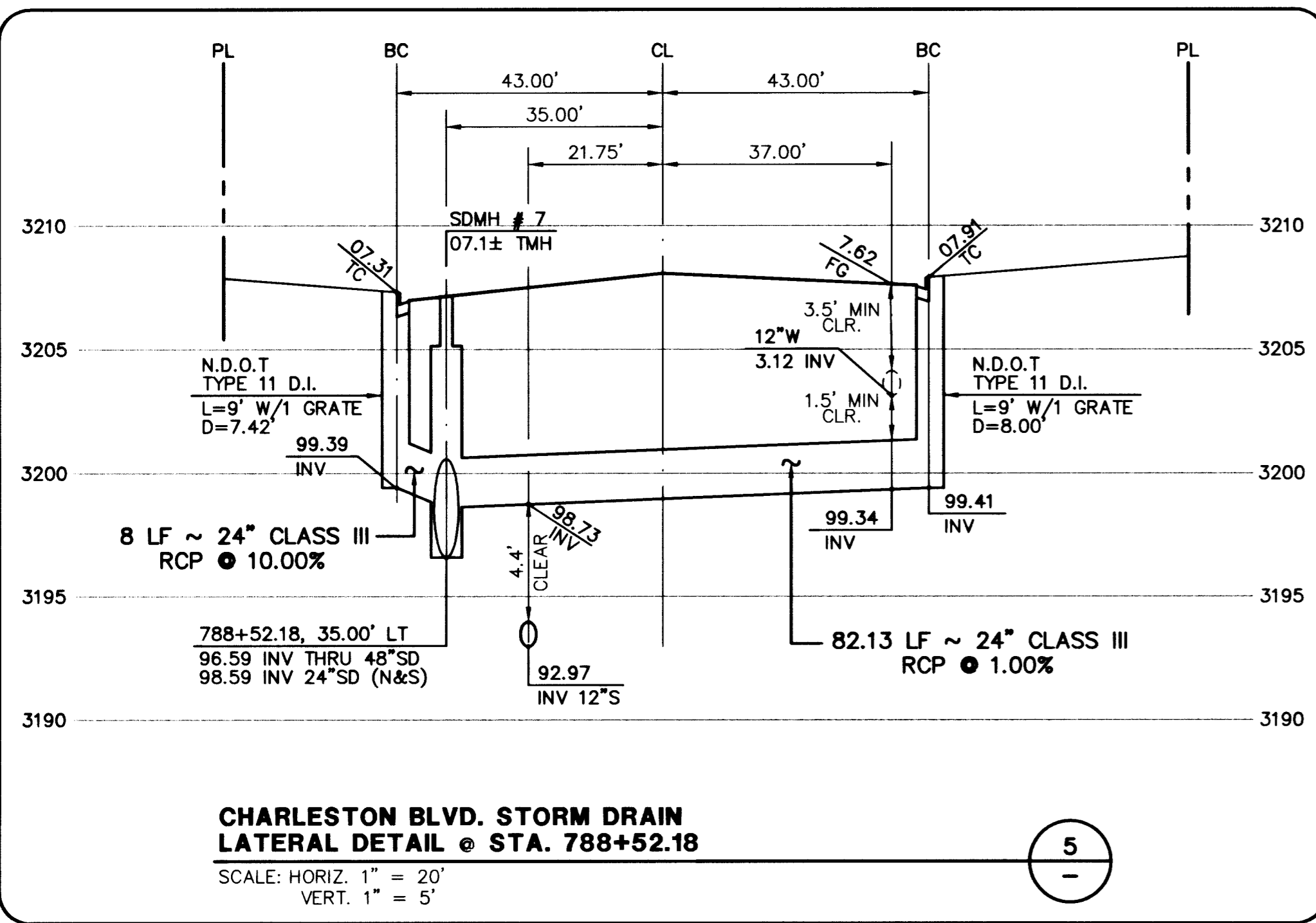

APPROVAL:
P. J. Daniel
 LAS VEGAS VALLEY WATER DISTRICT
 DATE: 9/12/12

G.C. WALLACE, INC.
 Engineers/Planners/Surveyors
 1555 SOUTH RAINBOW BLVD./LAS VEGAS, NEVADA 89146
 OFFICE: (702) 804-2000 FAX: (702) 804-2299
 OFFICE: (702) 804-2160 FAX: (702) 804-2295

SUMMERLIN
 VILLAGE 18/23A CHARLESTON BOULEVARD IMPROVEMENTS
 TYPICAL SECTION AND LATERAL PROFILES
 SHEET 12
 12 OF 21 SHEETS
 JOB NO. 62023.240