

- NOTES:**
1. PAINTED STRIPE COLOR TO BE 2" WIDE UNLESS OTHERWISE NOTED, TO BE WHITE TRAFFIC PAINT.
 2. EXACT LOCATION AND PLACEMENT OF BASKETBALL BACKBOARD/HOOP/NET ASSEMBLIES IN RELATIONSHIP TO COURT WILL DEPEND ON MANUFACTURER AND MODEL CHOSEN. CONTRACTOR TO INSTALL PER MANUFACTURER'S INSTRUCTIONS. COORDINATE EXACT LOCATION WITH OWNER PRIOR TO INSTALLATION.
 3. CONTRACTOR TO INSTALL PER MANUFACTURER'S SPECIFICATIONS.

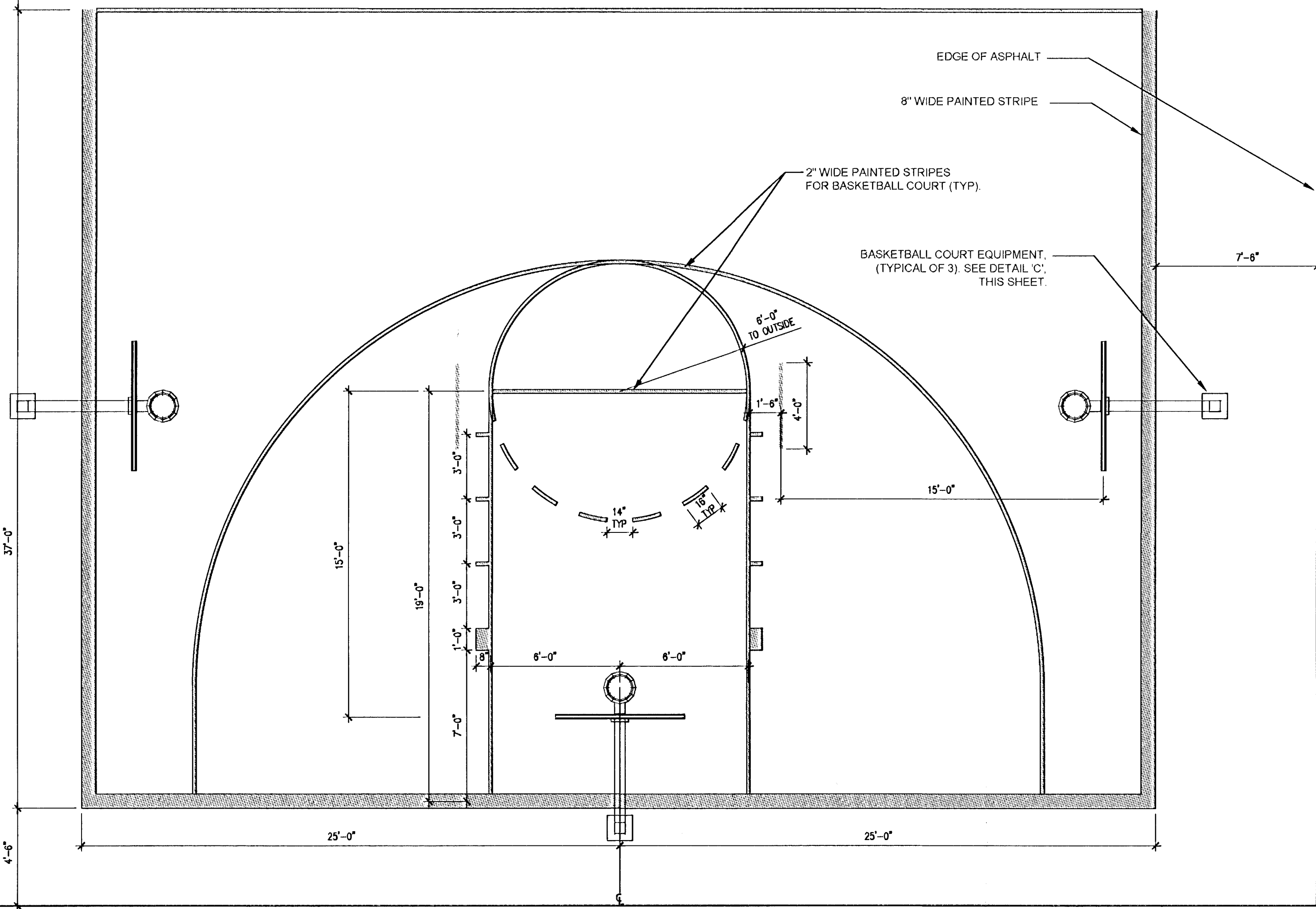
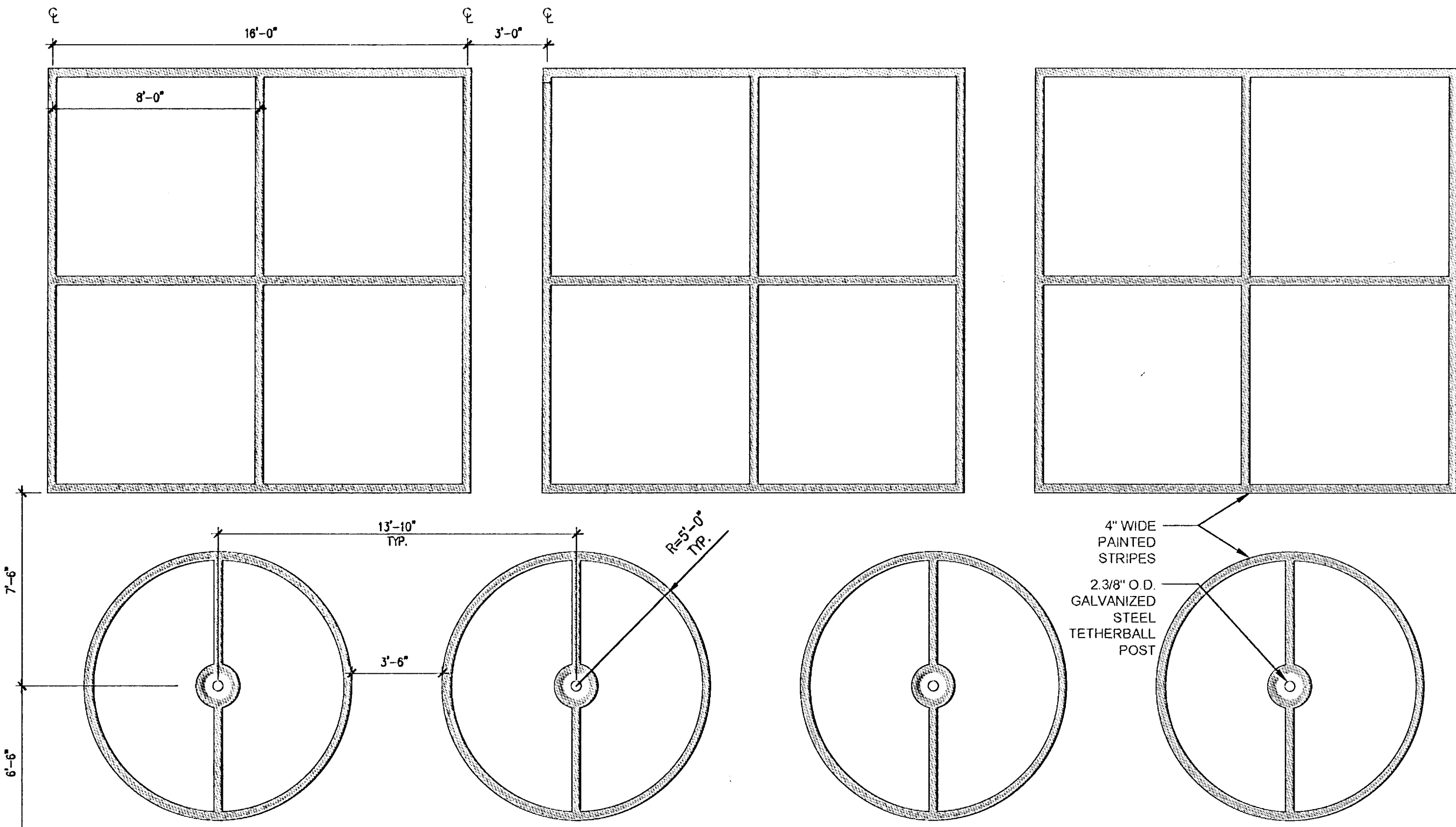

A SPORT COURT AREA ENLARGEMENT

1/4" = 1'-0"

- NOTES:**
1. DEPTH OF SBR CUSHION COURSE SHALL MEET OR EXCEED ASTM F1292 AND ASTM 355 FOR IMPACT ATTENUATION. SEE SPECIFICATIONS.
 2. SEE LANDSCAPE CONSTRUCTION SHEETS FOR LAYOUT AND COLORS.
 3. INSTALL PER MANUFACTURER'S INSTRUCTIONS.

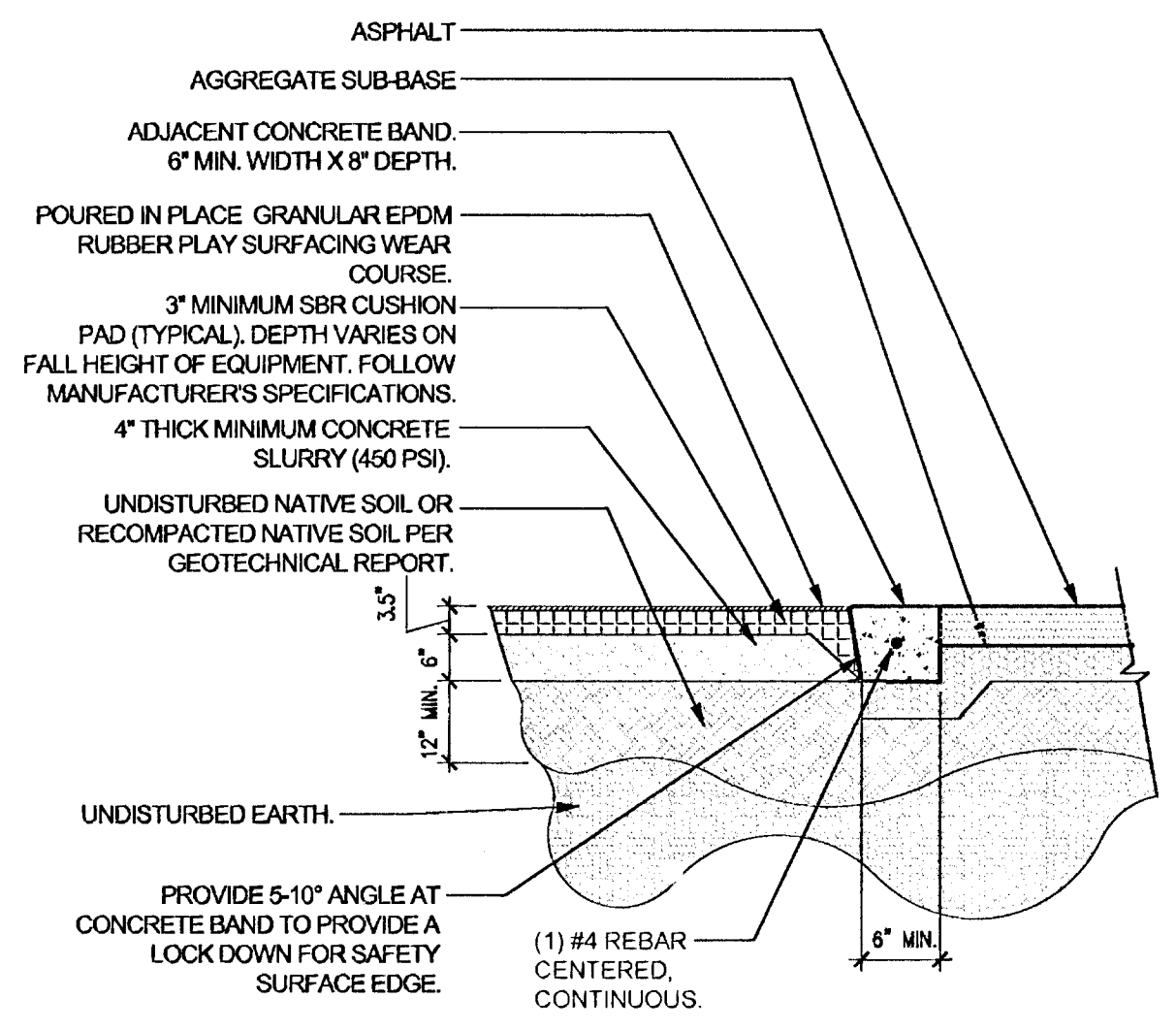

B SAFETY SURFACE

1/2" = 1'-0"

- NOTES:**
1. THIS DETAIL IS FOR DESIGN INTENT ONLY. CONTRACTOR TO INSTALL PER MANUFACTURER'S SPECIFICATIONS.
 2. SEE SHEET L1.00 FOR EQUIPMENT LIST. EXACT CONFIGURATION MAY VARY BASED ON MANUFACTURER AND MODEL.
 3. EXACT LOCATION OF BASKETBALL HOOP ASSEMBLIES TO BE COORDINATED WITH OWNER'S REPRESENTATIVE PRIOR TO INSTALLATION.

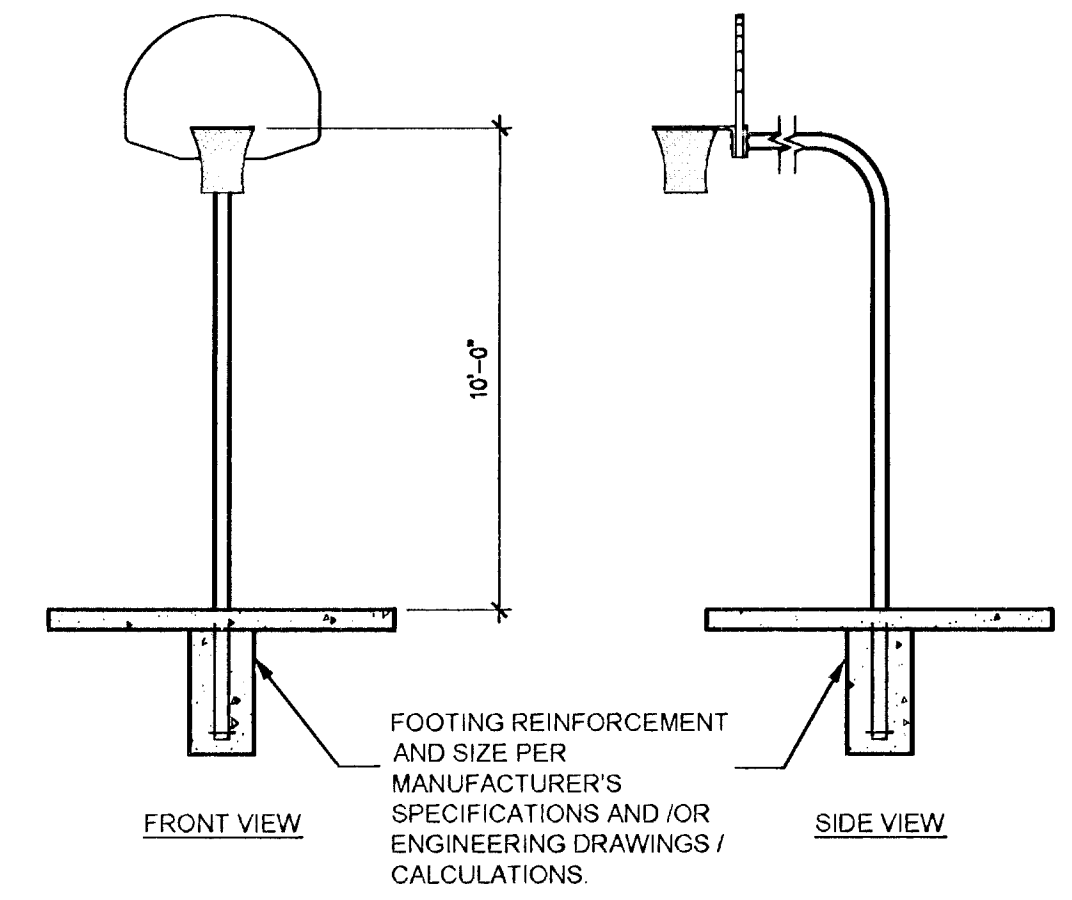

C BASKETBALL HOOP ASSEMBLY

1/4" = 1'-0"

- NOTES:**
1. SEE SHEET L1.00 FOR ALL COLORS AND FINISHES.
- RAISED PLANTER GARDEN SOIL TO BE: FERTA SUPER GROW SOIL AVAILABLE THROUGH WHITING BROTHERS, 702.457.4066, OR APPROVED EQUAL. AMENDMENTS FOR RAISED PLANTER GARDEN SOIL TO BE THE FOLLOWING:
- AMOUNT PER 1000 SQ. FT.
- 3.6 LBS. OF NITROGEN
 - 2.3 LBS. OF PHOSPHORUS
 - 4 LBS. OF ELEMENTAL SULFUR
 - 4 LBS. OF RECLAMATION IRON

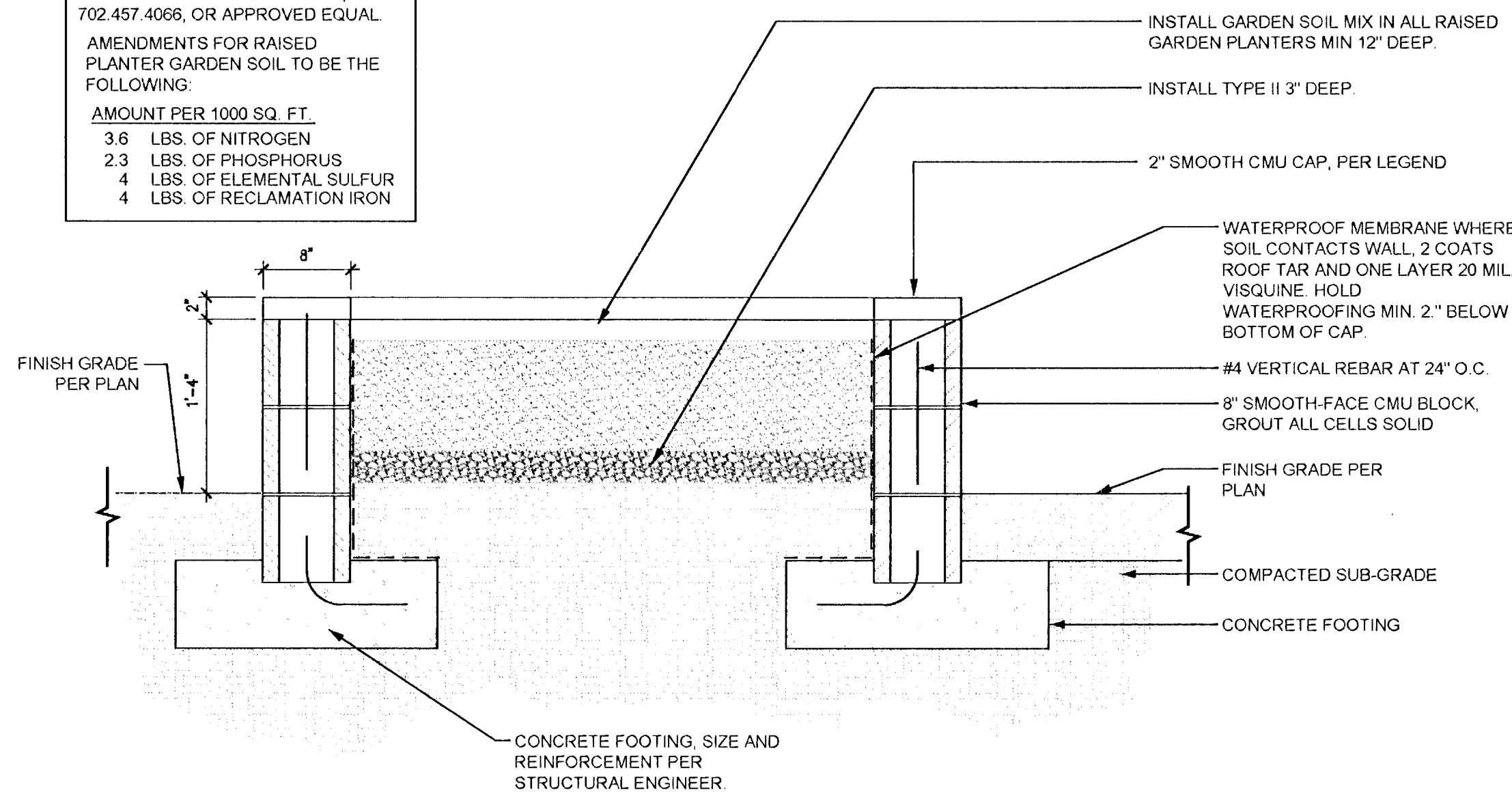

D RAISED PLANTER WALLS AT GARDEN

1" = 1'-0"

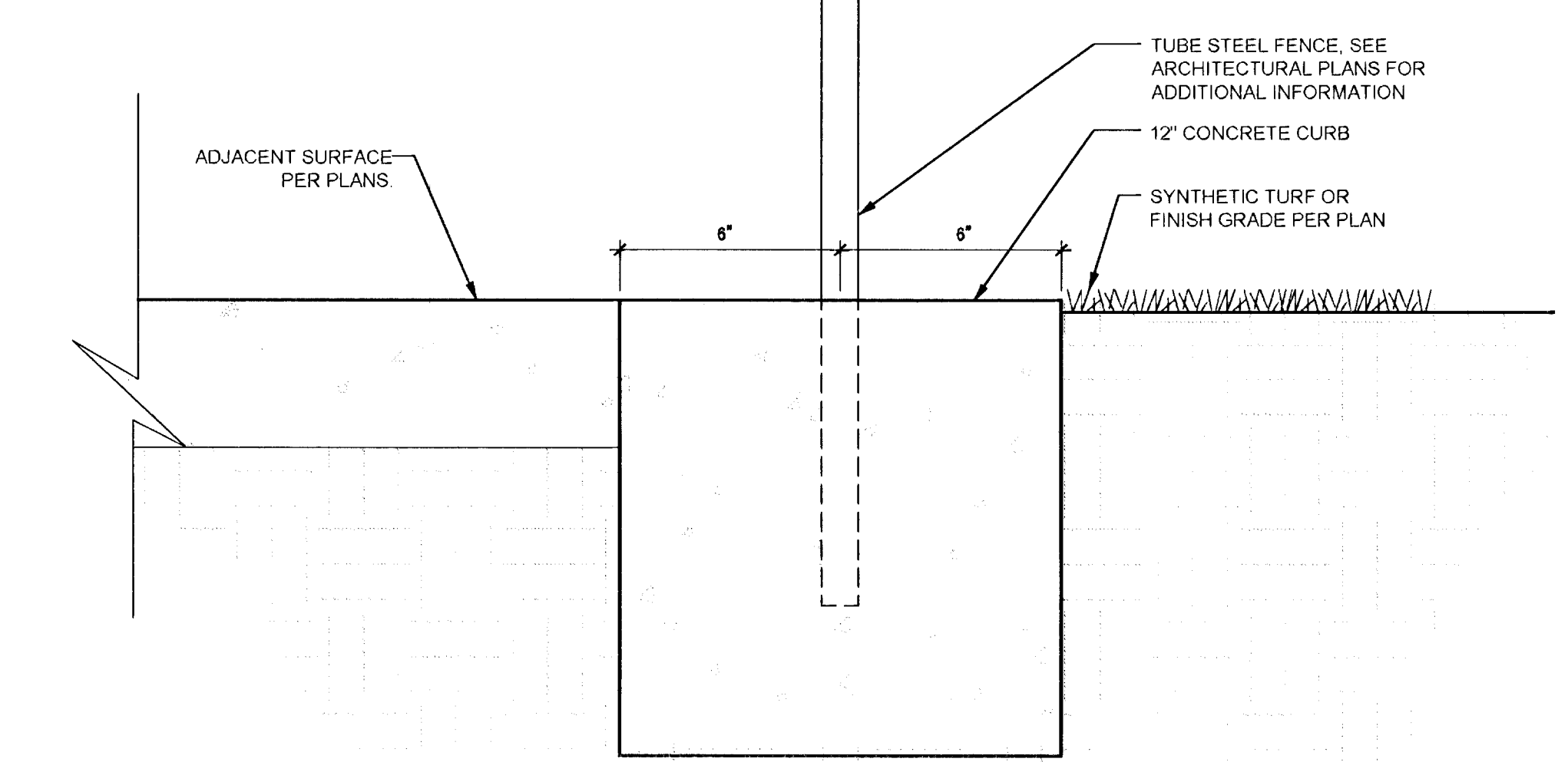

E CONCRETE CURB AT FENCE

3" = 1'-0"

REVISIONS			
REV	DESCRIPTION	DATE	BY

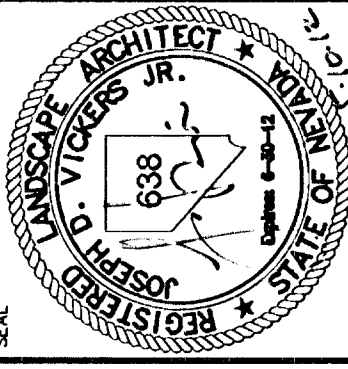

southwick
LANDSCAPE ARCHITECTS
12 Comstock Center Drive
Headtown NY 88014
www.southwick.com
702.597.3108

KGA ARCHITECTURE
9075 West Diablo Drive, Third Floor
Las Vegas, Nevada 89148
702.267.6900
www.kgaarchitecture.com
AUSTIN

CS&M PROJECT NO. 12522	DATE FEBRUARY 14, 2012
CS&M REVIEW	DRAWN BY IMF
APPROVED BY	CHECKED BY
DATE	SUBMITTAL
CONSTRUCTION SET	A/E PROJECT NO. 11-1024

CLARK COUNTY SCHOOL DISTRICT
DESIGN MANAGEMENT / PLANNING AND DESIGN
LAS VEGAS, NEVADA 89121
4170 McLEOD DRIVE
VARIETY SCHOOL
2800 EAST STEWART AVENUE
LANDSCAPE CONSTRUCTION DETAILS

SHEET NO.
H-113825
L1.02
DWS 715-3C