

60' ROW SECTION DETAIL
WHISPERING SANDS DRIVE

SECTION A - WHISPERING SANDS

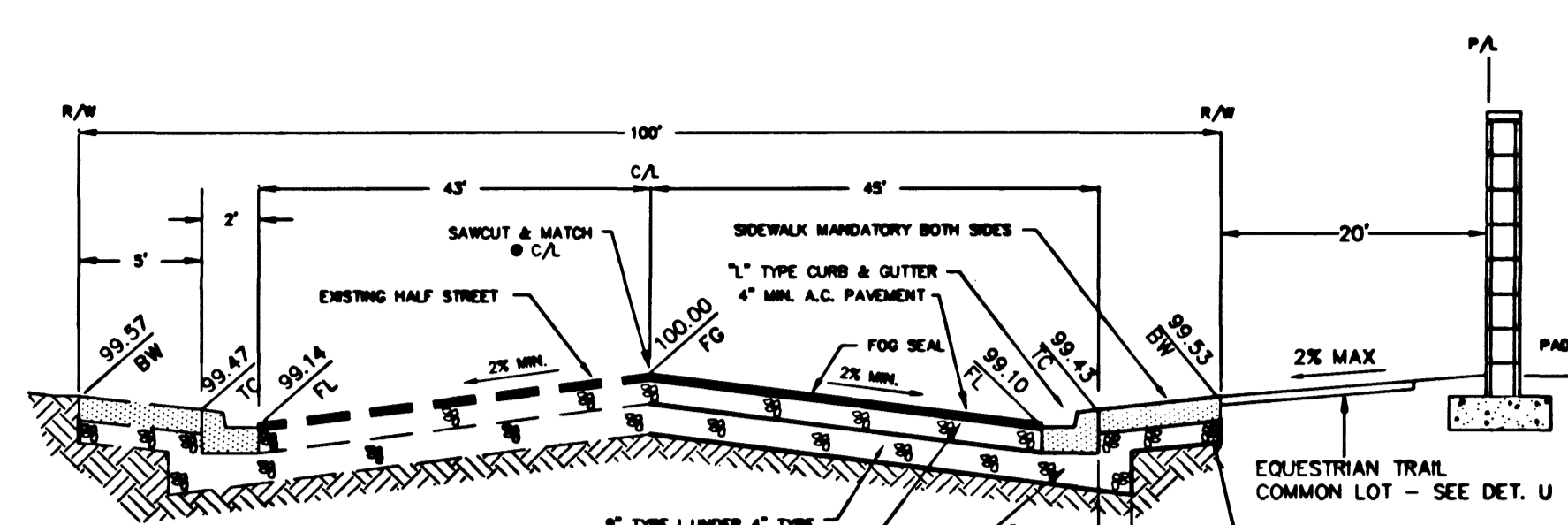

100' ROW SECTION DETAIL
BUFFALO DRIVE

SECTION B - BUFFALO DRIVE

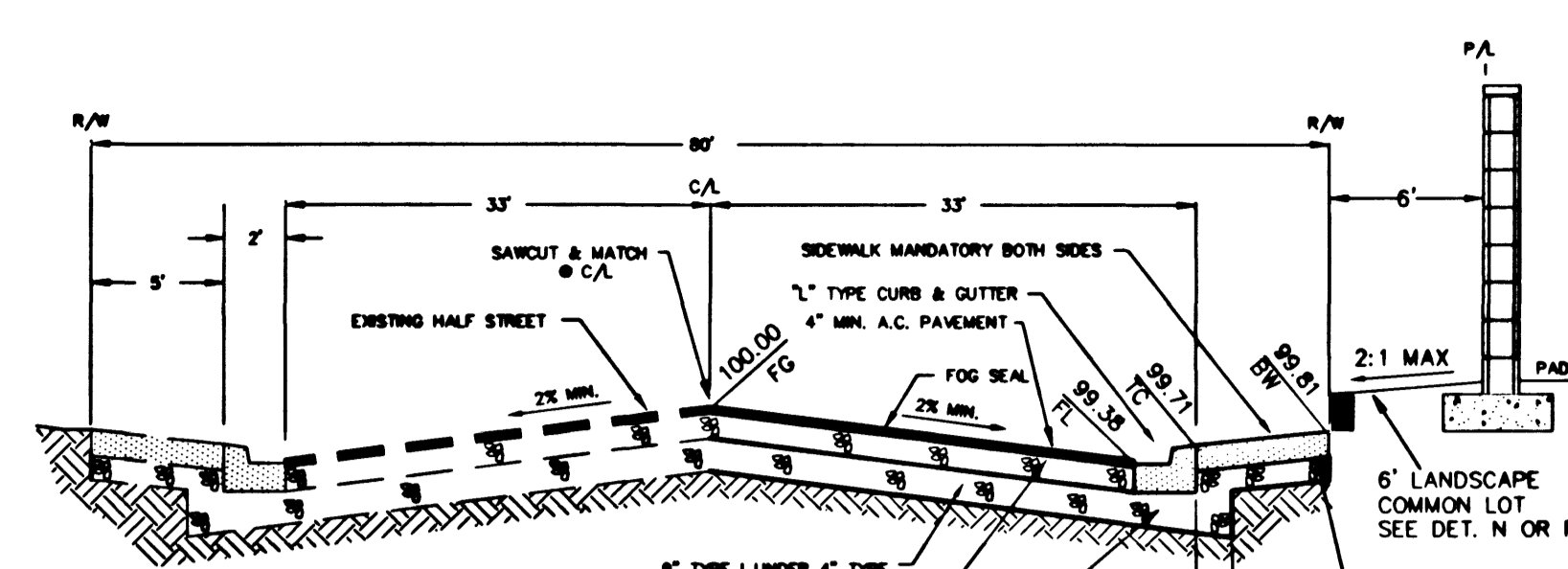

80' ROW SECTION DETAIL
FARM ROAD

SECTION C - FARM ROAD

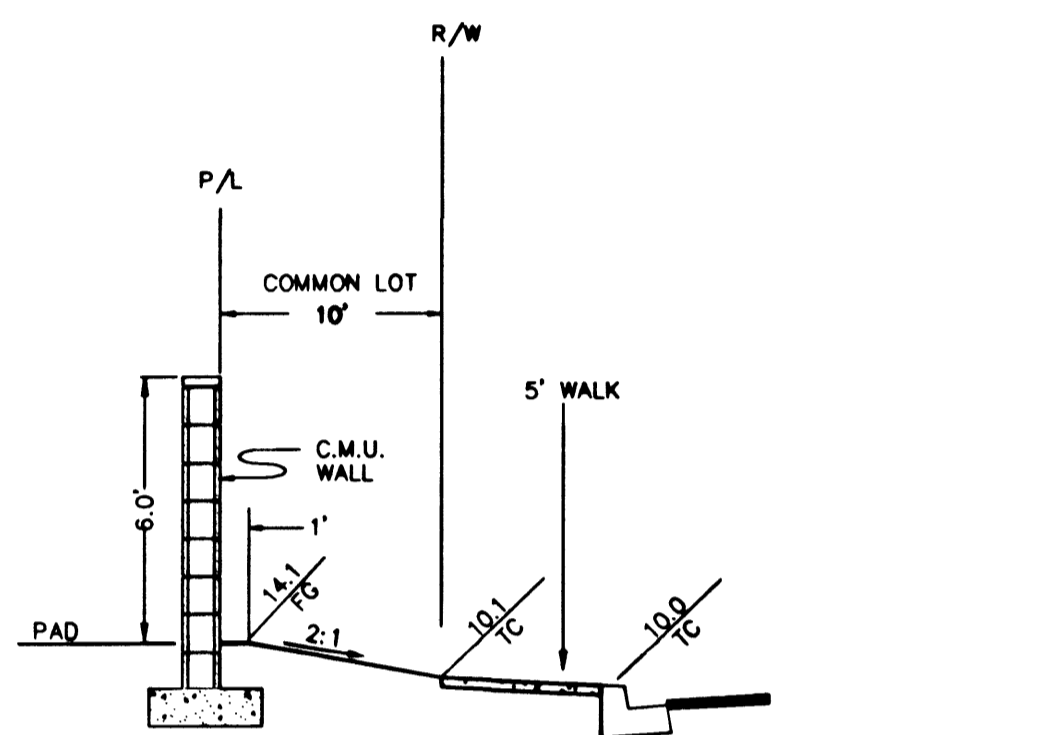

SECTION V - LANDSCAPE STRIP

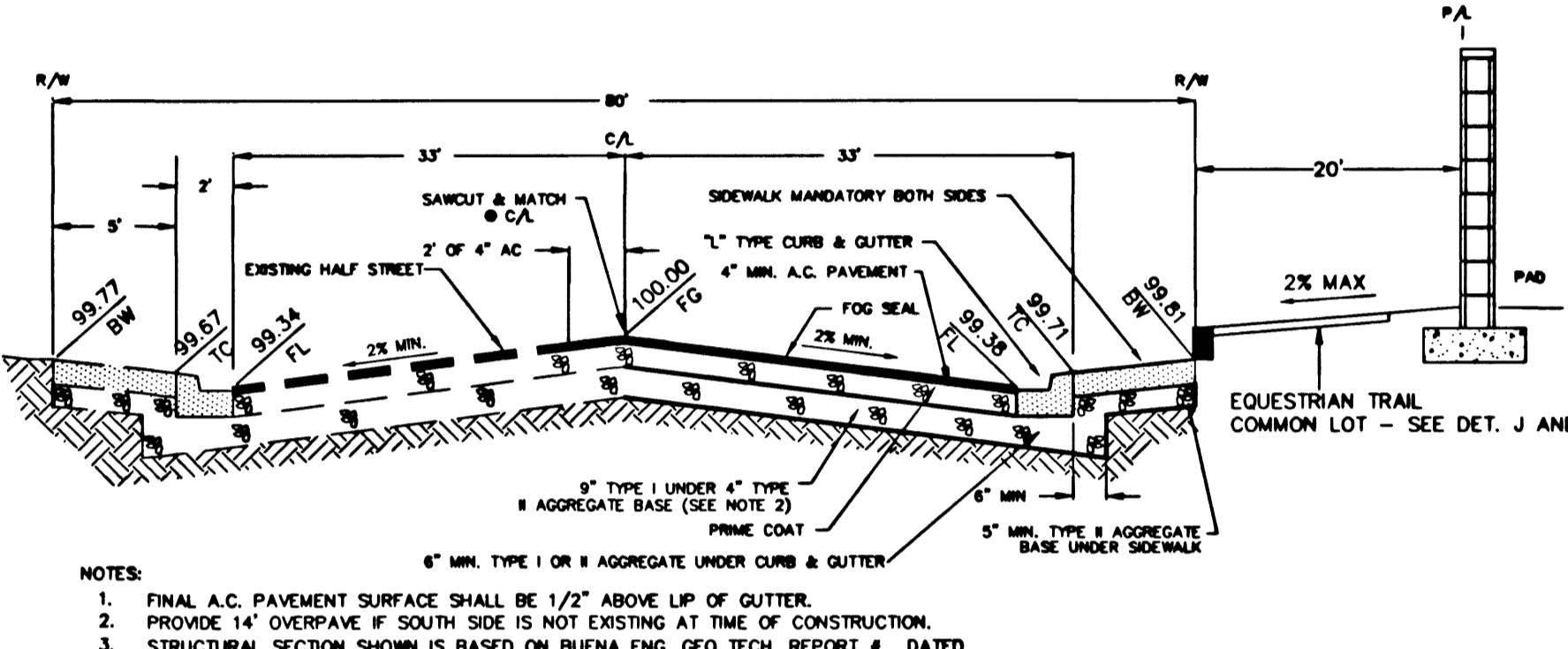

80' ROW SECTION DETAIL
FARM ROAD

SECTION D - FARM ROAD

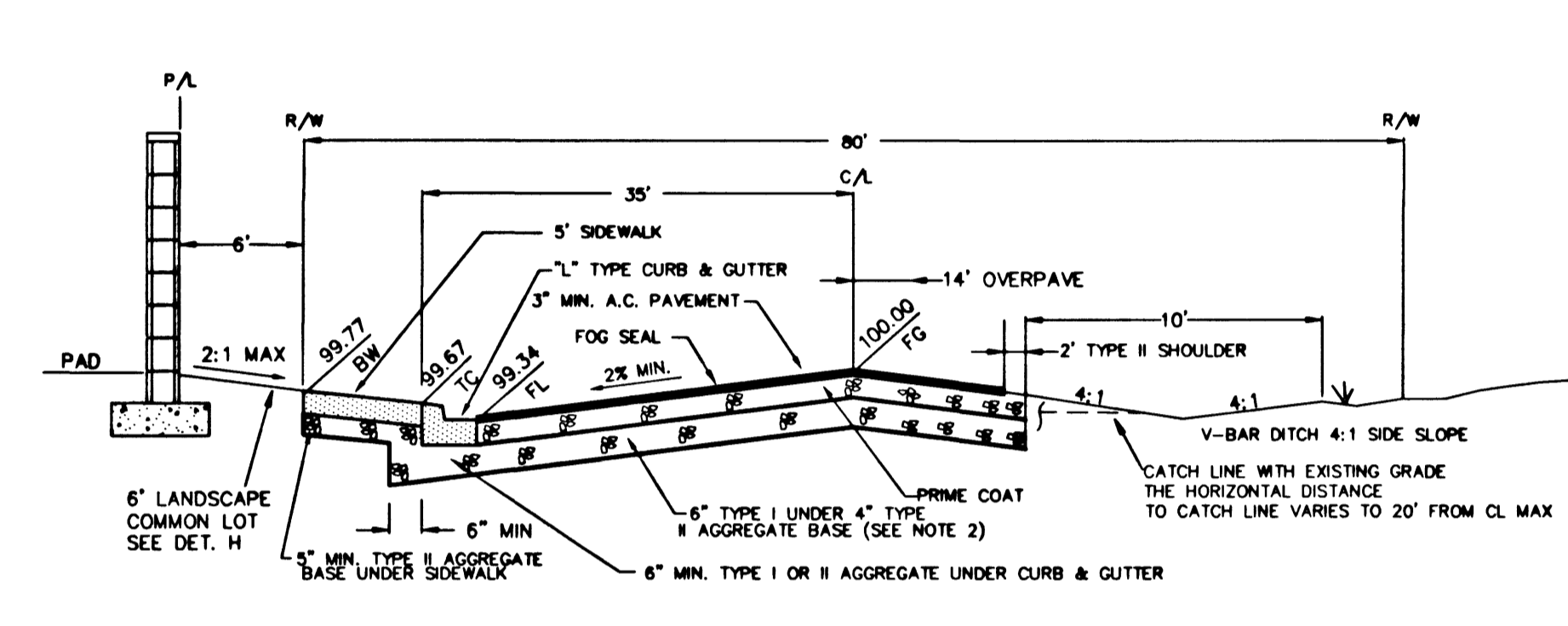

80' ROW SECTION DETAIL
TENAYA DRIVE

SECTION E - TENAYA ROAD

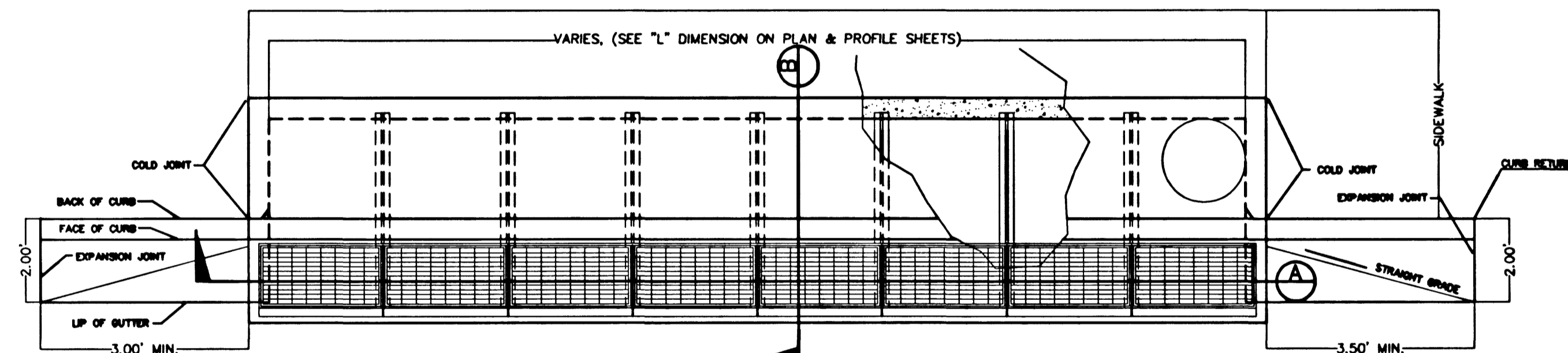

PLAN

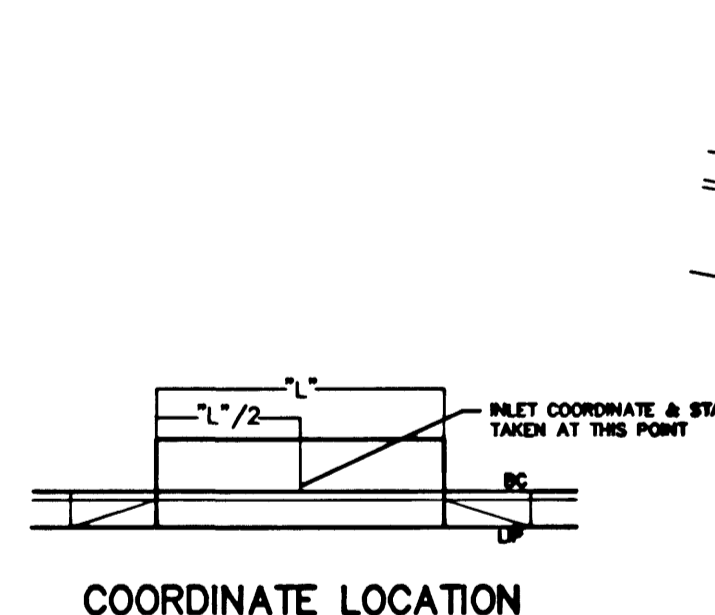

COORDINATE LOCATION

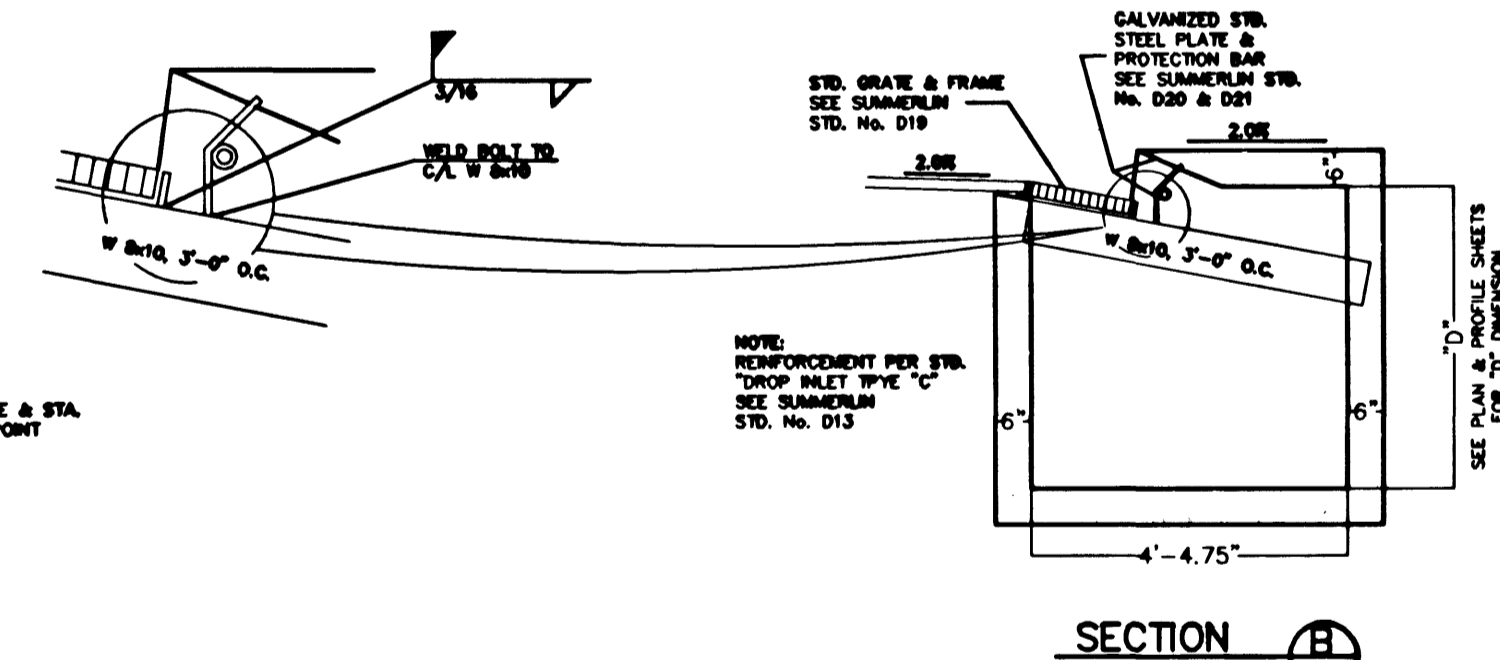

SECTION B

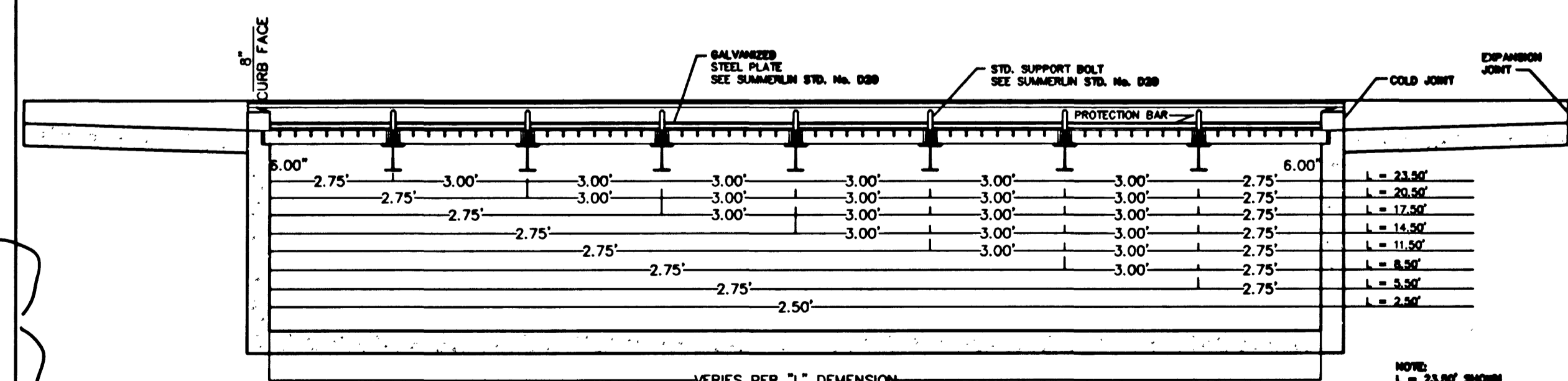

SECTION A

MODIFIED TYPE "C" DROP INLET
DETAIL F - MODIFIED TYPE C DROP INLET

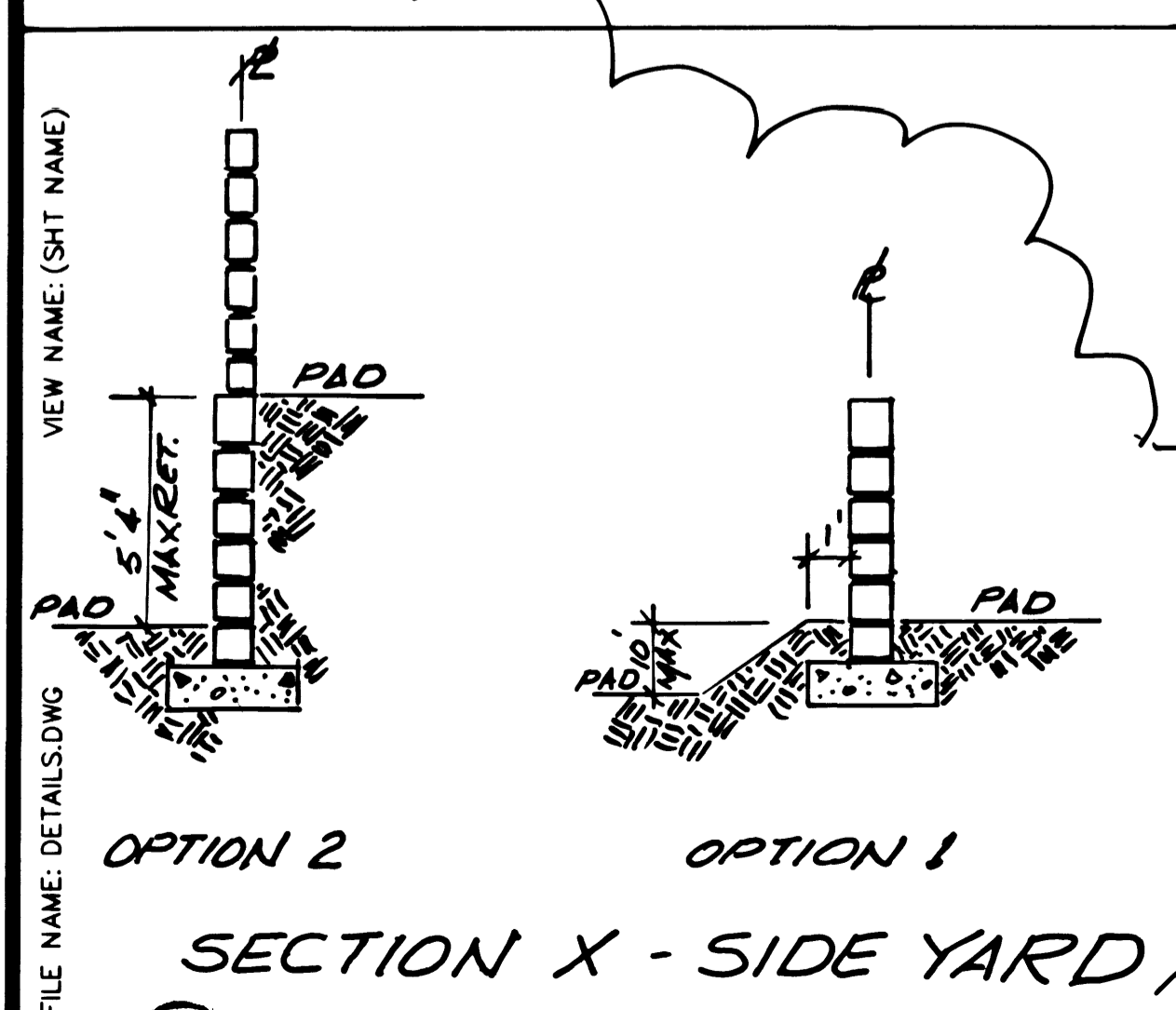

OPTION 2
OPTION 1
SECTION X - SIDE YARD

REVISION	DATE	BY

SPECTRUM DEVELOPMENT CO.
185 E. RENO #B-7
LAS VEGAS, NEVADA 89119
(702) 734-2400

ALPHA & ENGINEERING COMPANY
50 So. Jones #202, Las Vegas, NV 89107
Telephone: (702) 877-1300

GRADING DETAILS

TENAYA FARMS UNIT 1

DRAWN BY:	ET	7.16.99
DESIGNED BY:	ET	7.16.99
CHECKED BY:		
PROJECT NO.:	817701	
SCALE:	NONE	

EDWARD F. TANEY
REGISTERED PROFESSIONAL ENGINEER
CIVIL
NO. 9903
EXPIRES 12/31/01

1-3899

NOTICE!
EXISTING UTILITIES ARE SHOWN ON PLANS FOR THE CONVENIENCE OF THE CONTRACTOR ONLY. THE CONTRACTOR IS RESPONSIBLE FOR THE PROTECTION OF ALL UTILITIES. THE ENGINEER BEARS NO RESPONSIBILITY FOR UTILITIES NOT SHOWN OR SHOWN INCORRECTLY.

Call BEFORE YOU Dig

1-800-227-2600
UNDERGROUND SERVICE (USA)



FOR REVISION THIS SHEET



SECTION A - WEDDING SANDS



SECTION B - BUFFALO DRIVE



SECTION C - FARM ROAD



SECTION V - LANDSCAPE SERP



SECTION D - FARM ROAD

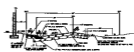

SECTION E - TEMAYA ROAD

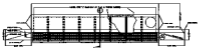

SECTION G



SECTION H



SECTION X - SIDE VIEW



DETAIL F - WOODED TYPE C DROP INLET



NO.	REVISION

SPECTRIAN DEVELOPMENT CO. 1000 W. 10th St. ALBUQUERQUE, N.M. 87102	SHEET NO. 06	PROJECT NO. 1000 W. 10th St.	DATE: 10/15/88	SCALE: AS SHOWN	DRAWN BY: J. H. HARRIS	CHECKED BY: J. H. HARRIS	APPROVED BY: J. H. HARRIS
SPECTRIAN DEVELOPMENT CO. 1000 W. 10th St. ALBUQUERQUE, N.M. 87102							
SHEET NO. 06 PROJECT NO. 1000 W. 10th St. DATE: 10/15/88 SCALE: AS SHOWN DRAWN BY: J. H. HARRIS CHECKED BY: J. H. HARRIS APPROVED BY: J. H. HARRIS							