



**BWA**  
LANDSCAPE  
ARCHITECTS

11001 Desert Dove Avenue  
Las Vegas, Nevada 89144  
(702) 244-2989  
FAX 242-4175

Drawings as instruments of service are and shall remain the property of the Landscape Architect.

Revision	By	Date	Rev

**SPINNAKER IV**  
Located @ Dorrell Ln. & Campbell Rd., Las Vegas, NV  
Prepared for: Royal Construction Company

Project Info

**Landscape Plan**

Sheet Title

Drawn By	3/14/06	Scale	1"=30'-0"
Designed By	3/14/06	Project #	06-023
Checked By	3/14/06		
Project #	06-023		

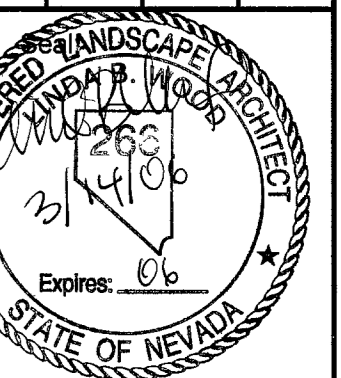

Sheet #

**L-1**

SHEET 1 OF 2

**PLANT LEGEND**

SYMBOL	BOTANICAL NAME	COMMON NAME	SIZE	REMARKS
○	FRAXINUS VELUTINA 'RIO GRANDE'	RIO GRANDE ASH	36" BOX	STANDARD TRUNK
+	ROBINIA AMBIGUA 'PURPLE ROBE'	ROBE LOCUST	36" BOX	STANDARD TRUNK
•••	ACACIA RED. 'DESERT CARPET'	DESERT CARPET ACACIA	1 GALLON	36" O.C.
□	MOJAVE GOLD DECOMPOSED GRANITE COBBLE, 3"-5" @ 6" DEPTH IN ALL PLANTER AREAS			

**NOTES:**

DISCREPANCIES BETWEEN THE DRAWINGS AND SITE SHALL BE BROUGHT TO THE ATTENTION OF THE LANDSCAPE ARCHITECT FOR CLARIFICATION BEFORE STARTING WORK.

CONTRACTOR SHALL VERIFY ALL EXISTING SITE CONDITIONS PRIOR TO STARTING WORK.

LANDSCAPE ARCHITECT OR HIS REPRESENTATIVE RESERVE THE RIGHT TO REFUSE ANY PLANT MATERIAL/ROCK MATERIAL DEEMED UNACCEPTABLE.

LANDSCAPE CONTRACTOR TO PROVIDE AGRONOMY TESTING FOR THIS SITE AND COMPLY WITH THE TESTING LAB'S RECOMMENDATIONS FOR BACKFILL MIX ADDITIVES. SUBMIT REPORT TO LANDSCAPE ARCHITECT.

BACKFILL MIX FOR ALL PLANTINGS (EXCEPT FOR PALMS) SHALL CONSIST OF THE FOLLOWING ELEMENTS BY PERCENTAGE OF VOLUME:

- 50% WASHED SILT
- 48% OMNI MULCH
- 1% SOIL SULPHUR
- 1% GYPSUM

OMNI MULCH AVAILABLE THROUGH THE FOLLOWING SOURCE:

WESTERN ORGANICS  
LAS VEGAS, NEVADA  
(702) 639-0370

QUANTITIES INDICATED ARE FOR CONVENIENCE ONLY. CONTRACTOR TO VERIFY ALL QUANTITIES.

ROCK MULCH AREAS TO BE TREATED BEFORE AND AFTER INSTALLATION WITH PRE-EMERGENT HERBICIDE.

ALL PLANTING AREAS SHALL RECEIVE ROCK MULCH. ROCK MULCH SHALL BE MOJAVE GOLD DECOMPOSED GRANITE COBBLE, 3"-5" AT A DEPTH OF 6". SUBMIT SAMPLES TO LANDSCAPE ARCHITECT. (SOURCE: KALAMAZOO MATERIALS OR APPROVED EQUAL.)

**NOTES:**

- ON ALL CURB RETURNS A 1/2" EXPANSION JOINT SHALL BE CONSTRUCTED BETWEEN THE BACK OF CURB AND THE SIDEWALK FOR THE ENTIRE LENGTH OF THE RETURN.
- THE TYPE II AGGREGATE BASE THICKNESS IS SHOWN ON THE TYPICAL SECTION DRAWING 202-207. REFER TO SPECS AND ENGINEERING DRAWINGS OF THE ROADWAY PLANS.
- LONGITUDINAL WEAKENED PLANE JOINT (CONTROL JOINT) REQUIRED AT MIDPOINT OF SIDEWALK 10' OR WIDER.
- SAND SWEEP ALL JOINTS - JOINTS BETWEEN PAVERS NOT TO EXCEED 1/8"
- SEE DETAIL R, THIS SHEET FOR PLAN VIEW OF PAVEMENT CONFIGURATION.

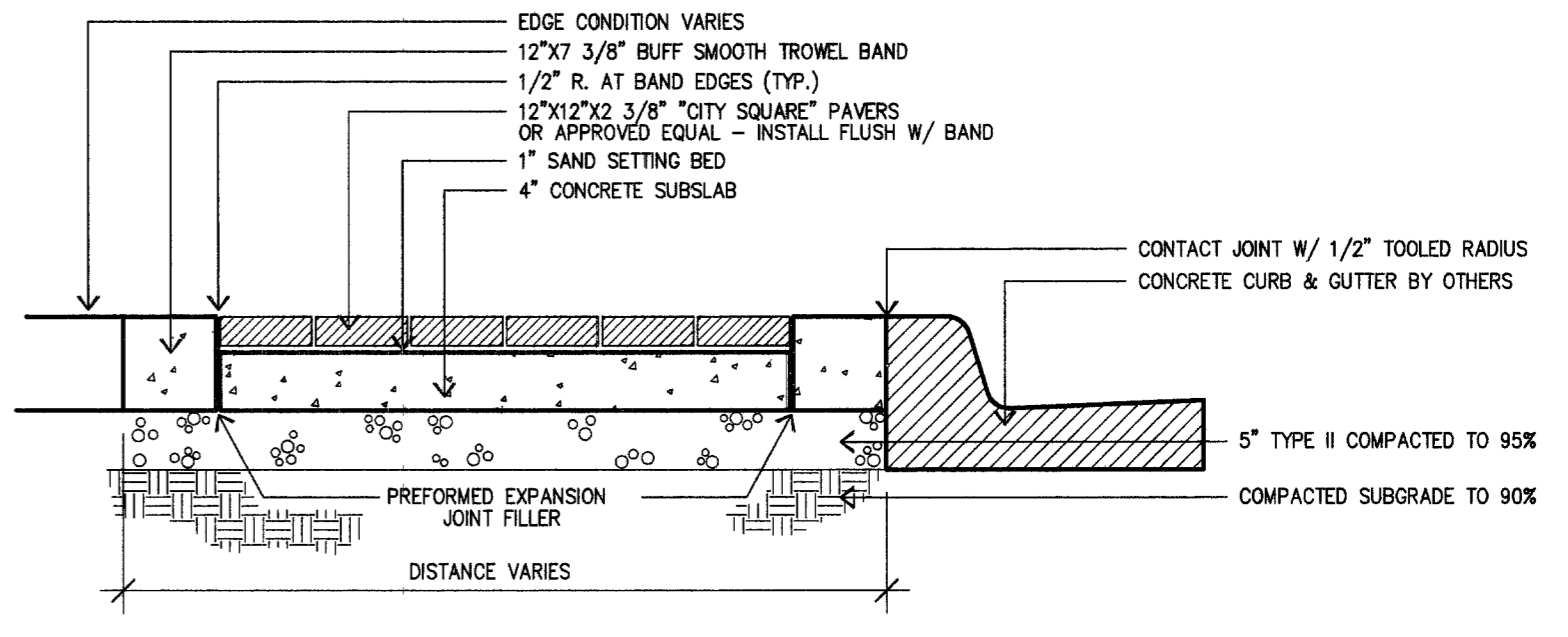

**(S) TYPICAL PAVER DETAIL**

Not To Scale

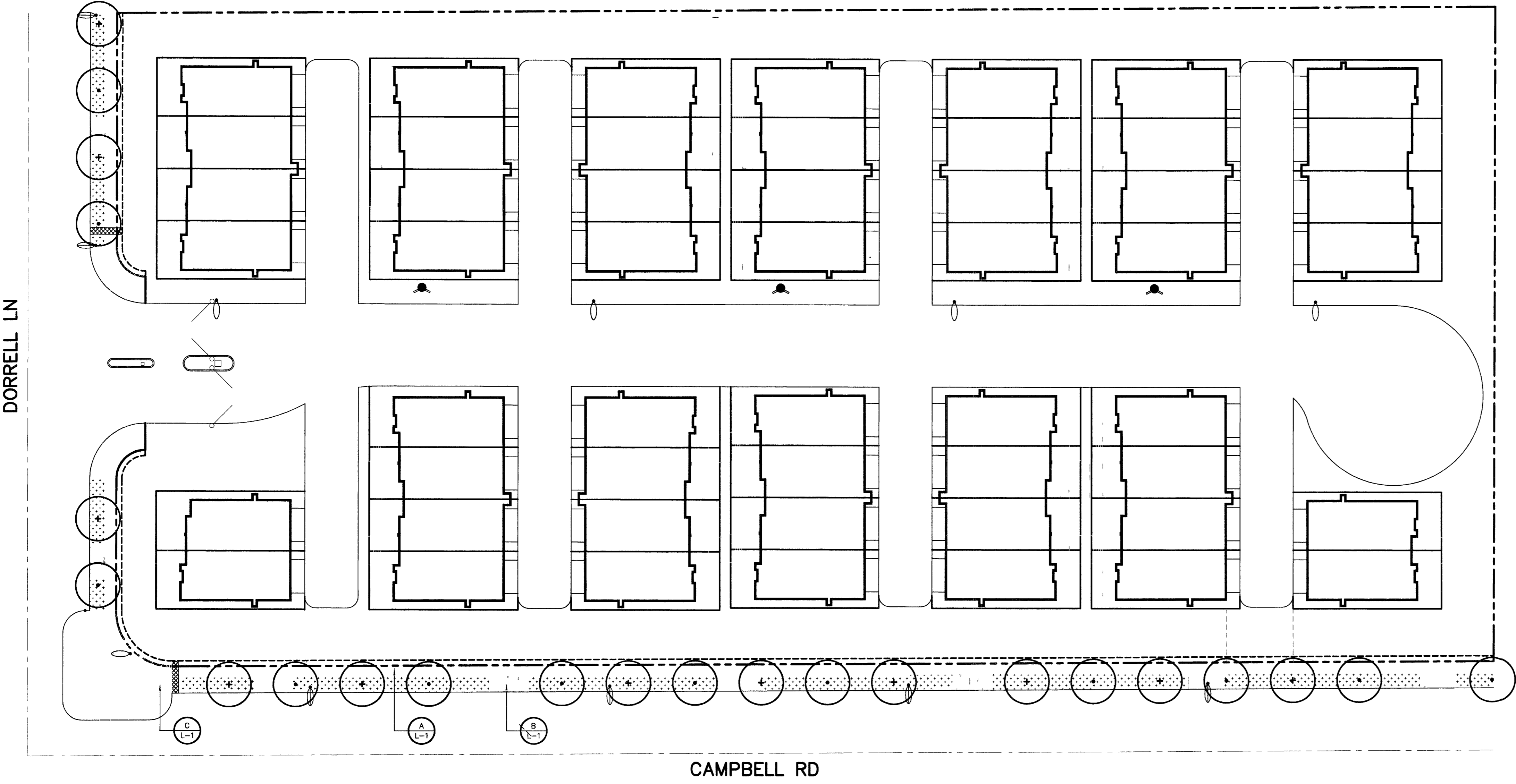

**CAMPBELL RD**

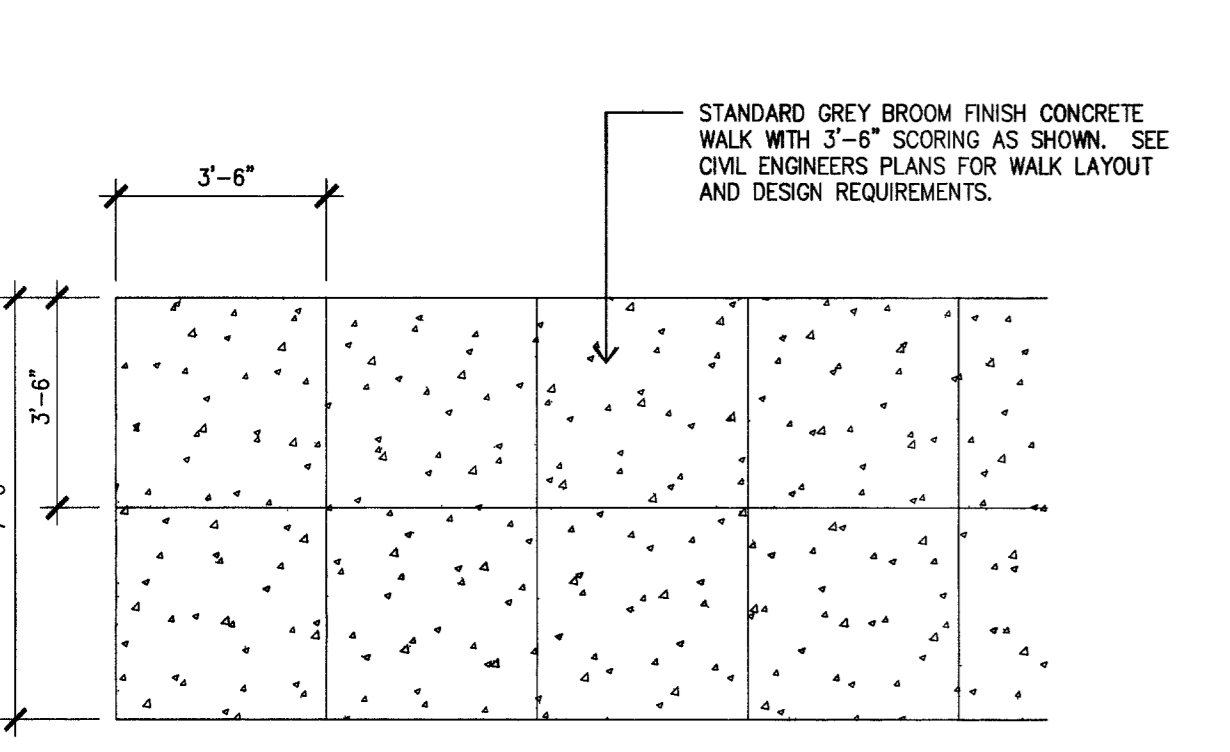

**(A) SIDEWALK SCORING PATTERN**

Not To Scale

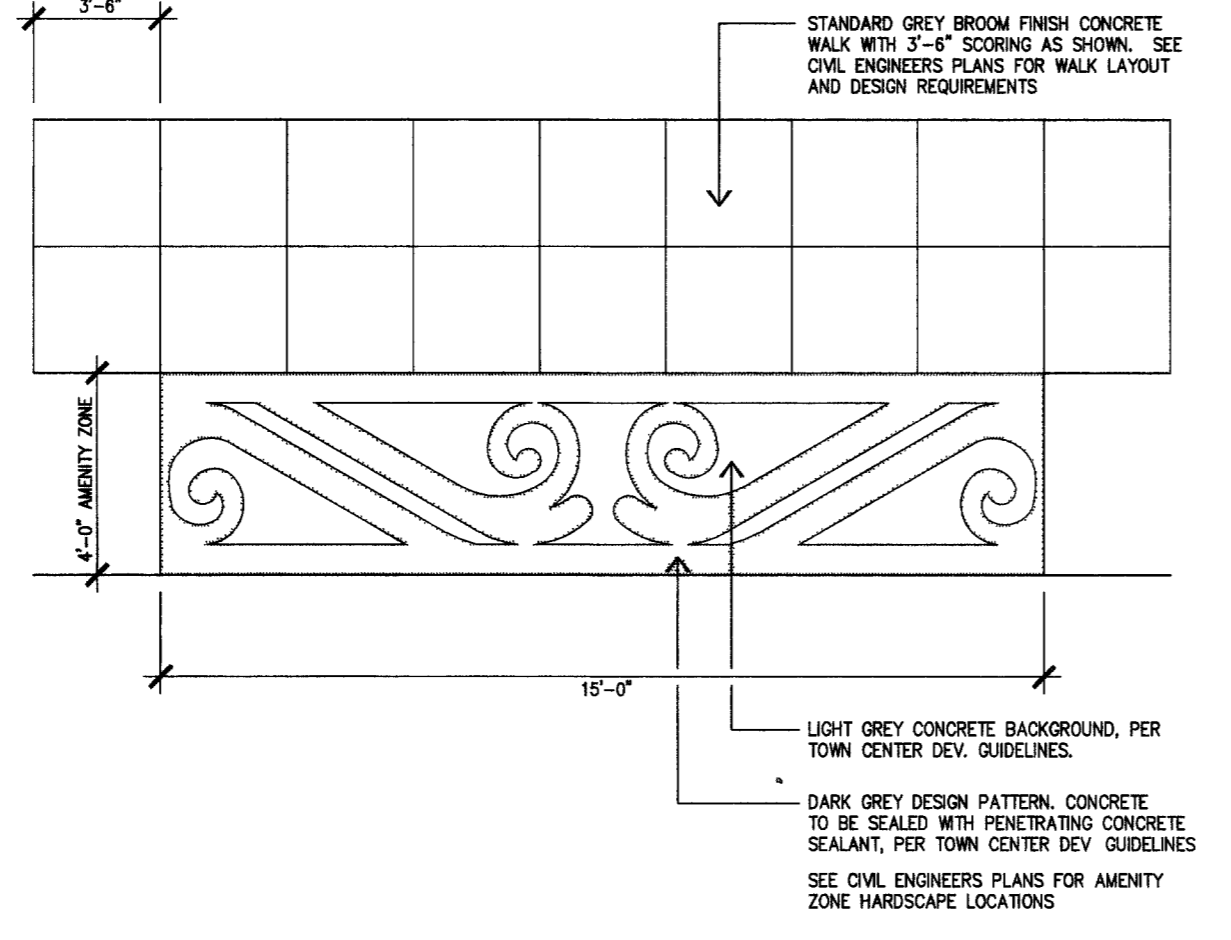

**(B) AMENITY ZONE HARDSCAPE**

Not To Scale

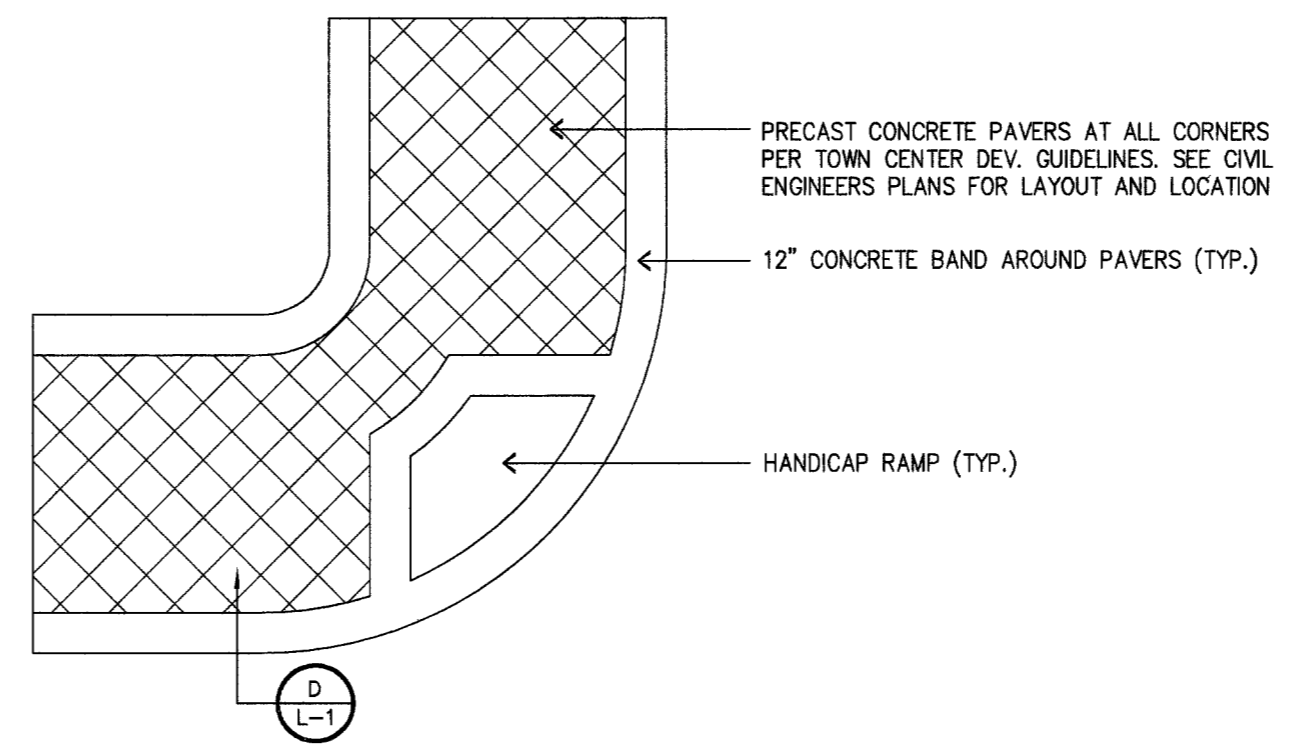

**(C) ENRICHED CORNER PAVING**

Not To Scale