

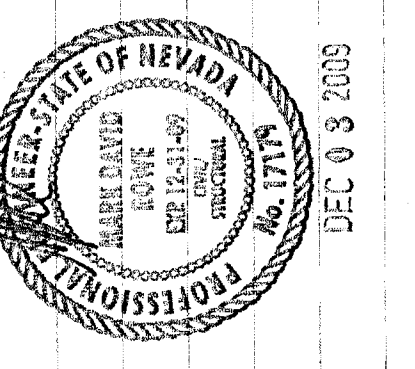

CONSULTANT  
**Cardno WRG**  
 LAS VEGAS  
 1049 JEFFREYS ST., HENDERSON, NV 89052  
 TEL: (702) 500-5000 FAX: (702) 500-5005  
 www.cardnowrg.com  
 PLANNERS - ENGINEERS - LANDSCAPE ARCHITECTS - SURVEYORS

SANDHILL OWENS PARK & TRAILHEAD  
 LAS VEGAS, NEVADA  
 FOUNDATION DETAILS



OWNER: CITY OF LAS VEGAS  
 DEPARTMENT OF PUBLIC WORKS  
 CAPITAL PROJECT MANAGEMENT SECTION

400 EAST STEWART AVENUE  
 LAS VEGAS, NEVADA 89101  
 PHONE: (702) 229-5535  
 FAX: (702) 388-1816  
 TDD: (702) 386-9108

DRAWN	9/5/05
FILE	S21-080403-0
DATE	10-15-2009
SCALE	AS NOTED
REV NO	08 15345.11
CLV DWG NO	558.104

100% SUBMITTAL  
 WRIGHT engineers  
 7425 PEAK DRIVE LAS VEGAS, NEVADA 89138  
 P 702.933.7000 F 702.933.7001 800.933.7911  
 WRIGHTENGINEERS.COM  
 LAS VEGAS - IRVINE - PHOENIX - SALT LAKE  
 SHEET NO. S2.1

① CHAIN LINK FENCE POST

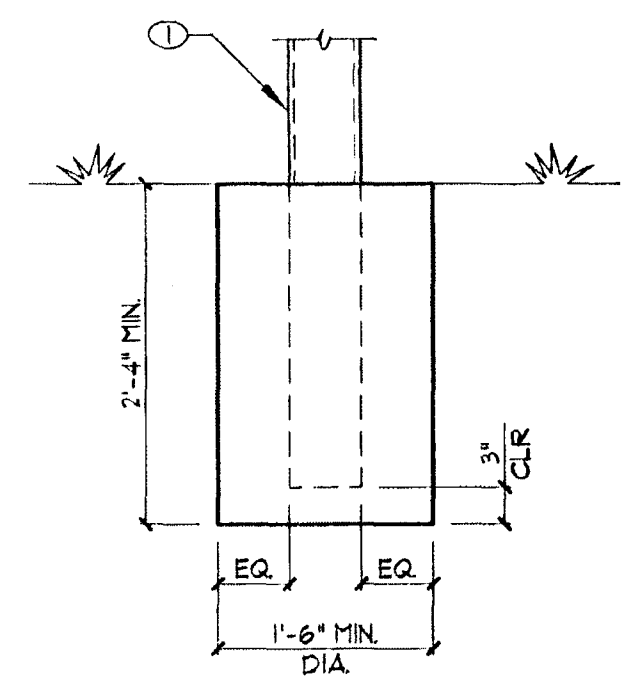

A. CHAIN LINK FENCE SHALL NOT EXCEED 6'-0\"/>

**103 CONCRETE FOOTING AT CHAIN LINK FENCE**  
 103-080403 NO SCALE

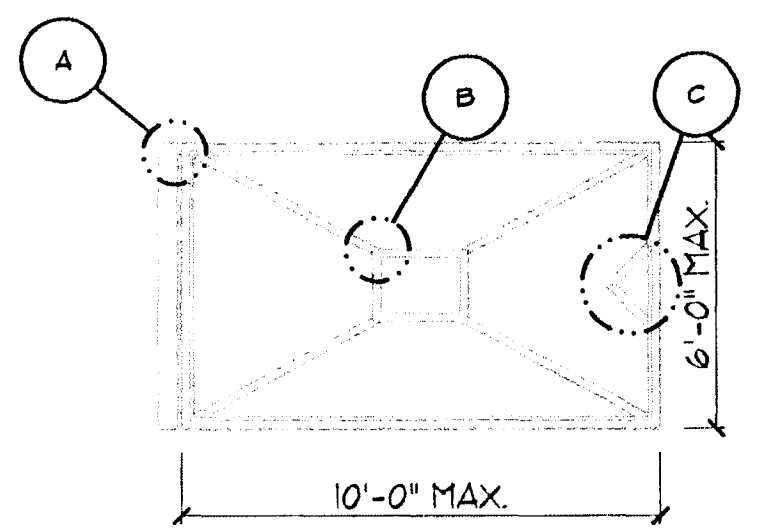

- ① STEEL GATE "SHIM" SEE NOTE A BELOW
- ② H8@12x1/8 INTERIOR STEEL FRAME MEMBERS, TYP.
- ③ H8@24x1/8 EXTERIOR STEEL FRAME MEMBERS

- A. REFER TO GATE HINGE COMPLETE ASSEMBLY DETAIL ON SHEET 52.4 FOR OTHER ITEMS AND REQUIREMENTS SHOWN BUT NOT NOTED.
- B. REFER TO DETAIL 5 ON SHEET 52.5 FOR GATE LATCH DESIGN AND ATTACHMENT.

**104 TRASH ENCLOSURE GATE CONNECTIONS**  
 104-080403 NO SCALE

- ① #4 VERT. AT 48\"/>
- ② #4 CONT.
- ③ #4 AT 48\"/>
- ④ ALTERNATE BENDS
- ⑤ NATURAL GRADE OR COMPACTED SUBGRADE

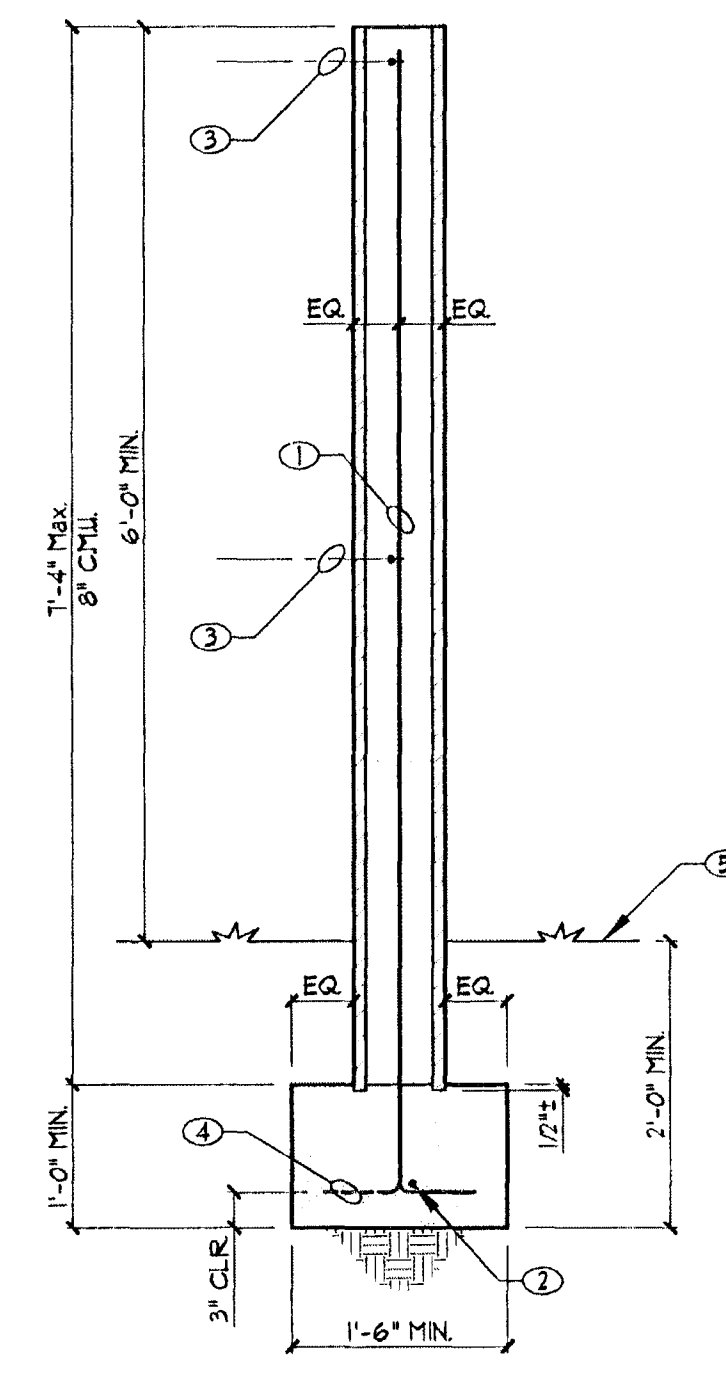

- A. SEE G&N FOR ADDITIONAL REQUIREMENTS AND ITEMS SHOWN BUT NOT NOTED
- B. GROUT WALL SOLID
- C. ALL REBAR LAP LENGTHS PER SCHEDULE, UNO.

**101 6\"/>
 101-080403 NO SCALE**

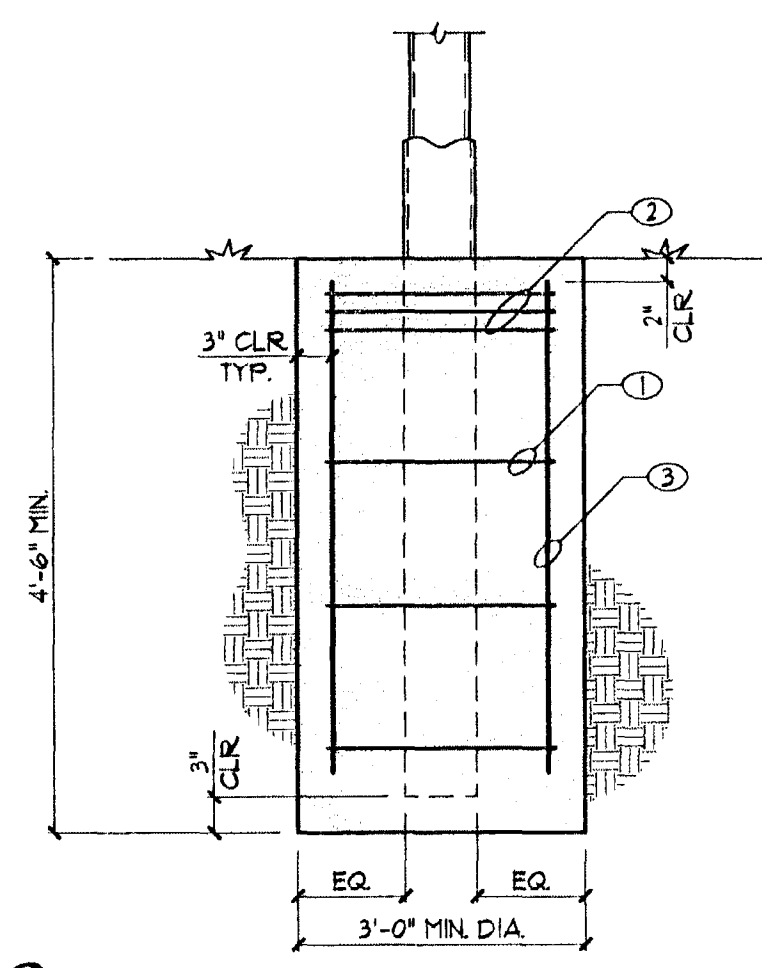

- ① #3 TIES AT 12\"/>
- ② (3) #3 HOOPS WITHIN 6\"/>
- ③ (6) #3 VERTICAL

- A. REFER TO GATE HINGE COMPLETE ASSEMBLY DETAIL FOR OTHER ITEMS AND REQUIREMENTS SHOWN BUT NOT NOTED.

**102 TRASH ENCLOSURE GATE FOOTING**  
 102-080403 NO SCALE

12-31-07