

FUNNEL BALL AVAILABLE FROM PROGRESSIVE DESIGN PLAYGROUNDS 2665 VISTA PACIFIC DR. OCEANSIDE, CA 92056 TOLL FREE: 1-800-585-3131 PHONE: (760) 597-5990 FAX: (760) 597-5991 www.pdplay.com. MODEL: FUNNEL BALL, OR APPROVED EQUAL. COLORS 1. LOWER PORTION OF BODY - GREEN 2. UPPER PORTIONS OF BODY - GREEN.

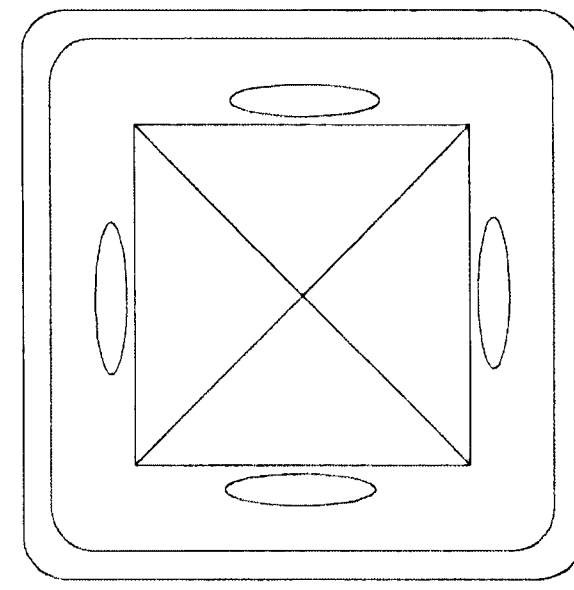

PLAN VIEW NOT TO SCALE

FUNNEL BALL AVAILABLE FROM PROGRESSIVE DESIGN PLAYGROUNDS 2665 VISTA PACIFIC DR. OCEANSIDE, CA 92056 TOLL FREE: 1-800-585-3131 PHONE: (760) 597-5990 FAX: (760) 597-5991 www.pdplay.com. MODEL: FUNNEL BALL, OR APPROVED EQUAL. COLORS 1. LOWER PORTION OF BODY - GREEN 2. UPPER PORTIONS OF BODY - GREEN.

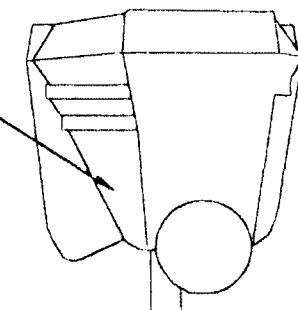

FUNNEL BALL POST - COLOR: GREEN

CONCRETE FINISH GRADE PER PLAN

12" LAYER TYPE II COMPACTED MIN. 95%
90% COMPACTED FINE-GRAINED FILL

SCARIFY EXPOSED SOIL TO A DEPTH OF 6", WATERED AS NECESSARY, RECOMPACT TO 95% MIN.

90% COMPACTED SUBGRADE

ELEVATION NOT TO SCALE

6 FUNNEL BALL

SCALE: NTS

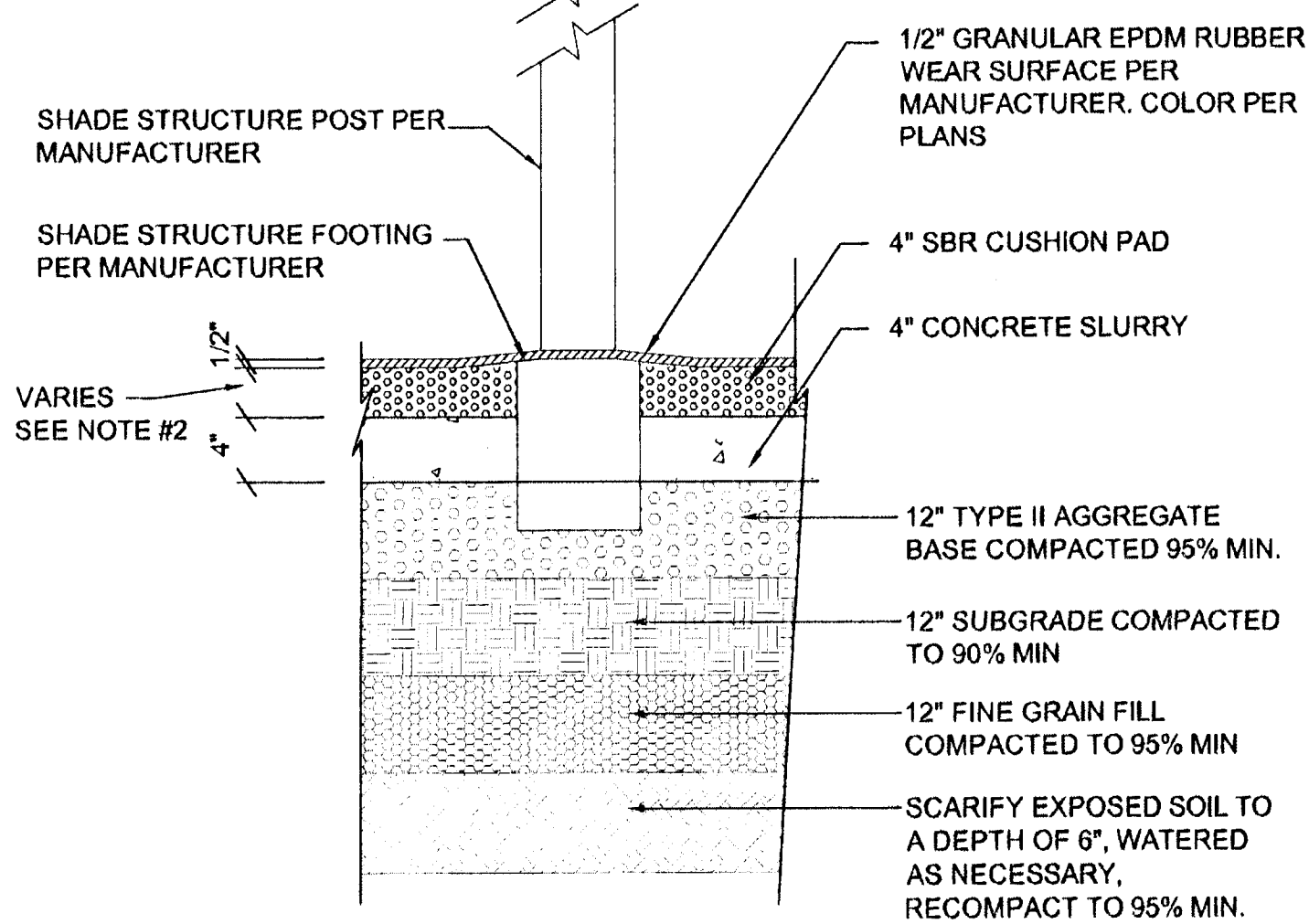

- NOTES:
- OWNERS REPRESENTATIVE SHALL APPROVE FORMWORK PRIOR TO PLACING CONCRETE.
 - CONCRETE UNDERNEATH THE RESILIENT SURFACE IS TO BE TYPE V, 2500 PSI AT 28 DAYS MINIMUM.
 - ALL SPILL OF EXCESS CONCRETE SHALL BE CLEANED UP AND REMOVED FROM SITE BY THE CONTRACTOR.
 - GRADING AT CURB SHALL BE BY THE CONTRACTOR.
 - CONTRACTOR SHALL INSTALL SAFETY SURFACE AS PER MANUFACTURER'S SPECIFICATIONS AND RECOMMENDATIONS.
 - SBR CUSHION PAD DEPTH SHALL BE DETERMINED BY SAFETY SURFACE MANUFACTURER BASED ON THE PLAYGROUND EQUIPMENT FALL HEIGHT
 - RESILIENT TOT LOT SURFACE TO BE 1/3, 1/3 MIX OF BLACK, BEIGE AND GREEN IN EQUAL PROPORTIONS.
 - MANUFACTURER: TOT TURF, 7665 COMMERCIAL WAY, SUITE H HENDERSON, NV 89015. 702-303-8701 OR APPROVED EQUAL.
 - COMPLY WITH THE LATEST VERSION OF:
 - THE PROPOSED ACCESSIBILITY GUIDELINES FOR PLAY AREAS AS PUBLISHED BY THE ARCHITECTURAL AND TRANSPORTATION BARRIERS COMPLIANCE BOARD.
 - U.S. CONSUMER PRODUCT SAFETY COMMISSION'S HANDBOOK FOR PUBLIC PLAYGROUND SAFETY. ASTM F 1487 AND ASTM F 1292, LATEST EDITIONS.

7 EPDM SURFACE TREATMENT AT SHADE SAIL POLE

SCALE: NTS

4 RESILIENT SURFACE WITH CONCRETE HEADER

SCALE: NTS

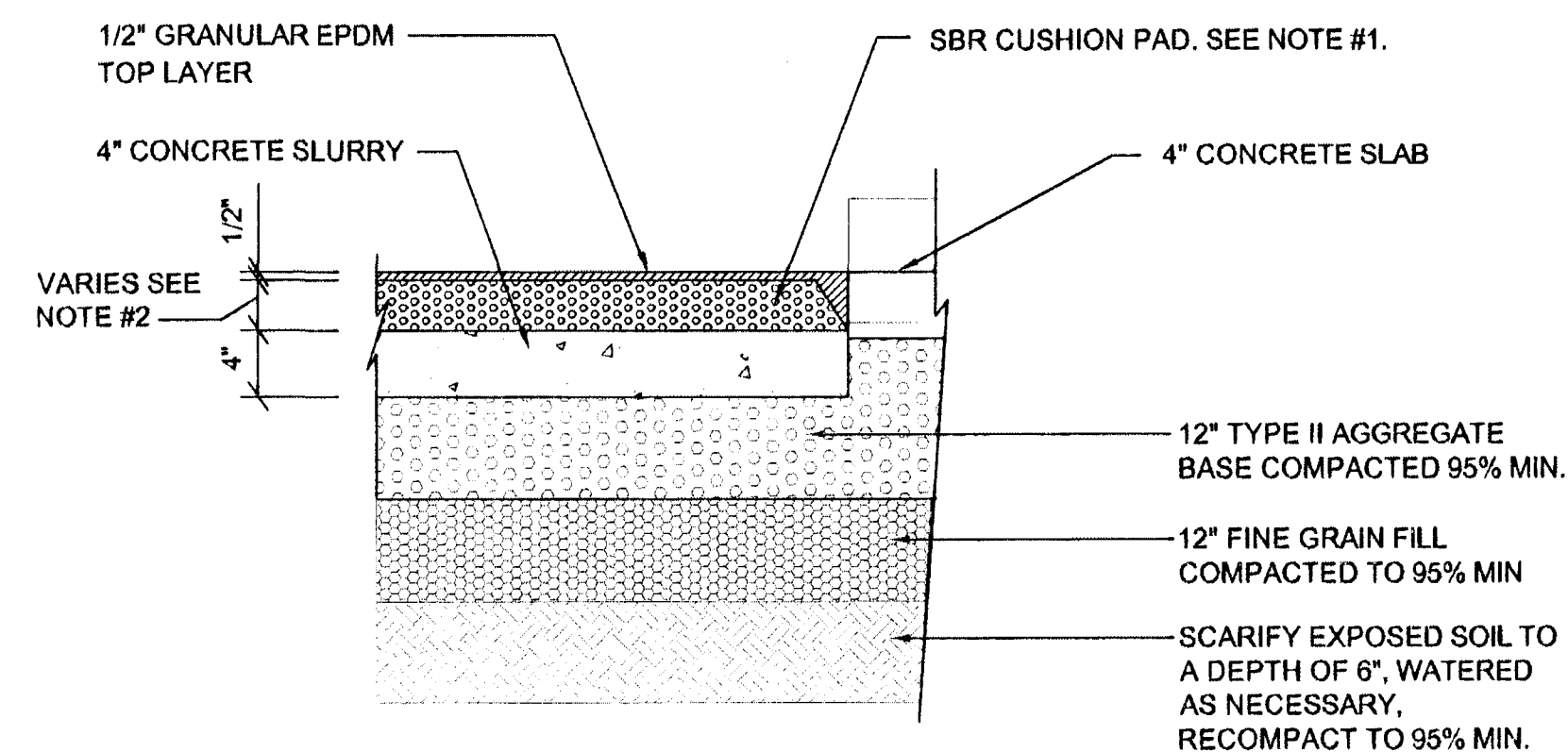

- NOTES:
- OWNERS REPRESENTATIVE SHALL APPROVE FORMWORK PRIOR TO PLACING CONCRETE.
 - CONCRETE UNDERNEATH THE RESILIENT SURFACE IS TO BE TYPE V, 2500 PSI AT 28 DAYS MINIMUM.
 - ALL SPILL OF EXCESS CONCRETE SHALL BE CLEANED UP AND REMOVED FROM SITE BY THE CONTRACTOR.
 - GRADING AT CURB SHALL BE BY THE CONTRACTOR.
 - CONTRACTOR SHALL INSTALL SAFETY SURFACE AS PER MANUFACTURER'S SPECIFICATIONS AND RECOMMENDATIONS.
 - SBR CUSHION PAD DEPTH SHALL BE DETERMINED BY SAFETY SURFACE MANUFACTURER BASED ON THE PLAYGROUND EQUIPMENT FALL HEIGHT
 - MANUFACTURER: TOT TURF, 7665 COMMERCIAL WAY, SUITE H HENDERSON, NV 89015. 702-303-8701 OR APPROVED EQUAL.

5 RESILIENT SURFACE AT CONCRETE WALKWAY

SCALE: NTS

3 RESILIENT SURFACE INSTALLATION NOTES

SCALE: NTS

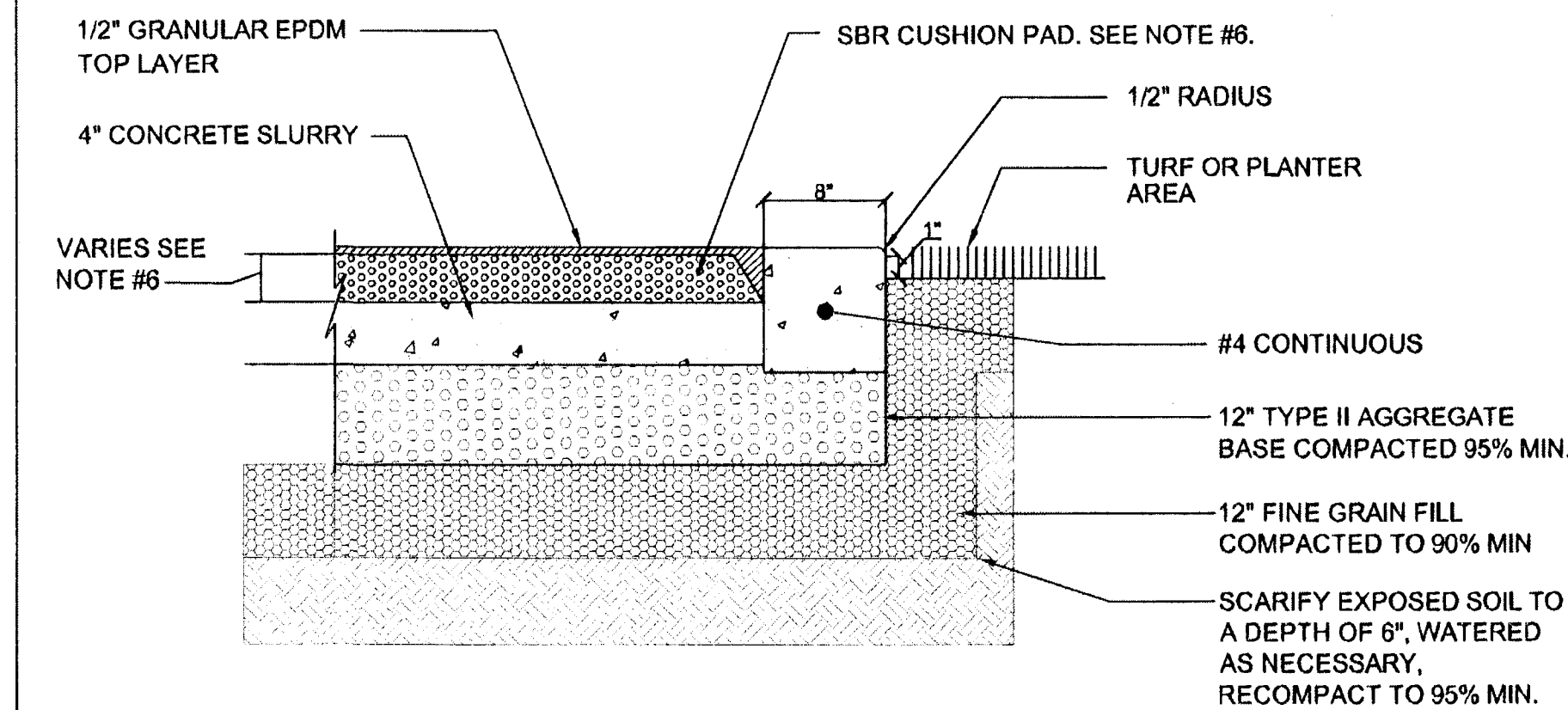

- NOTES:
- OWNERS REPRESENTATIVE SHALL APPROVE FORMWORK PRIOR TO PLACING CONCRETE.
 - CONCRETE UNDERNEATH THE RESILIENT SURFACE IS TO BE TYPE V, 2500 PSI AT 28 DAYS MINIMUM.
 - ALL SPILL OF EXCESS CONCRETE SHALL BE CLEANED UP AND REMOVED FROM SITE BY THE CONTRACTOR.
 - GRADING AT CURB SHALL BE BY THE CONTRACTOR.
 - CONTRACTOR SHALL INSTALL SAFETY SURFACE AS PER MANUFACTURER'S SPECIFICATIONS AND RECOMMENDATIONS.
 - SBR CUSHION PAD DEPTH SHALL BE DETERMINED BY SAFETY SURFACE MANUFACTURER BASED ON THE PLAYGROUND EQUIPMENT FALL HEIGHT
 - MANUFACTURER: TOT TURF, 7665 COMMERCIAL WAY, SUITE H, HENDERSON, NV 89015. 702-303-8701 OR APPROVED EQUAL.

- NOTES:
- OWNERS REPRESENTATIVE SHALL APPROVE FORMWORK PRIOR TO PLACING CONCRETE.
 - CONCRETE UNDERNEATH THE RESILIENT SURFACE IS TO BE TYPE V, 2500 PSI AT 28 DAYS MINIMUM.
 - ALL SPILL OF EXCESS CONCRETE SHALL BE CLEANED UP AND REMOVED FROM SITE BY THE CONTRACTOR.
 - GRADING AT CURB SHALL BE BY THE CONTRACTOR.
 - CONTRACTOR SHALL INSTALL SAFETY SURFACE AS PER MANUFACTURER'S SPECIFICATIONS AND RECOMMENDATIONS.
 - SBR CUSHION PAD DEPTH SHALL BE DETERMINED BY SAFETY SURFACE MANUFACTURER BASED ON THE PLAYGROUND EQUIPMENT FALL HEIGHT
 - RESILIENT TOT LOT SURFACE TO BE 1/3, 1/3 MIX OF BLACK, BEIGE AND GREEN IN EQUAL PROPORTIONS.
 - MANUFACTURER: TOT TURF, 7665 COMMERCIAL WAY, SUITE H HENDERSON, NV 89015. 702-303-8701 OR APPROVED EQUAL
 - COMPLY WITH THE LATEST VERSION OF:
 - THE PROPOSED ACCESSIBILITY GUIDELINES FOR PLAY AREAS AS PUBLISHED BY THE ARCHITECTURAL AND TRANSPORTATION BARRIERS COMPLIANCE BOARD.
 - U.S. CONSUMER PRODUCT SAFETY COMMISSION'S HANDBOOK FOR PUBLIC PLAYGROUND SAFETY. ASTM F 1487 AND ASTM F 1292, LATEST EDITIONS.

1 PLAYGROUND AREA LAYOUT

SCALE: 1" = 10'-0"

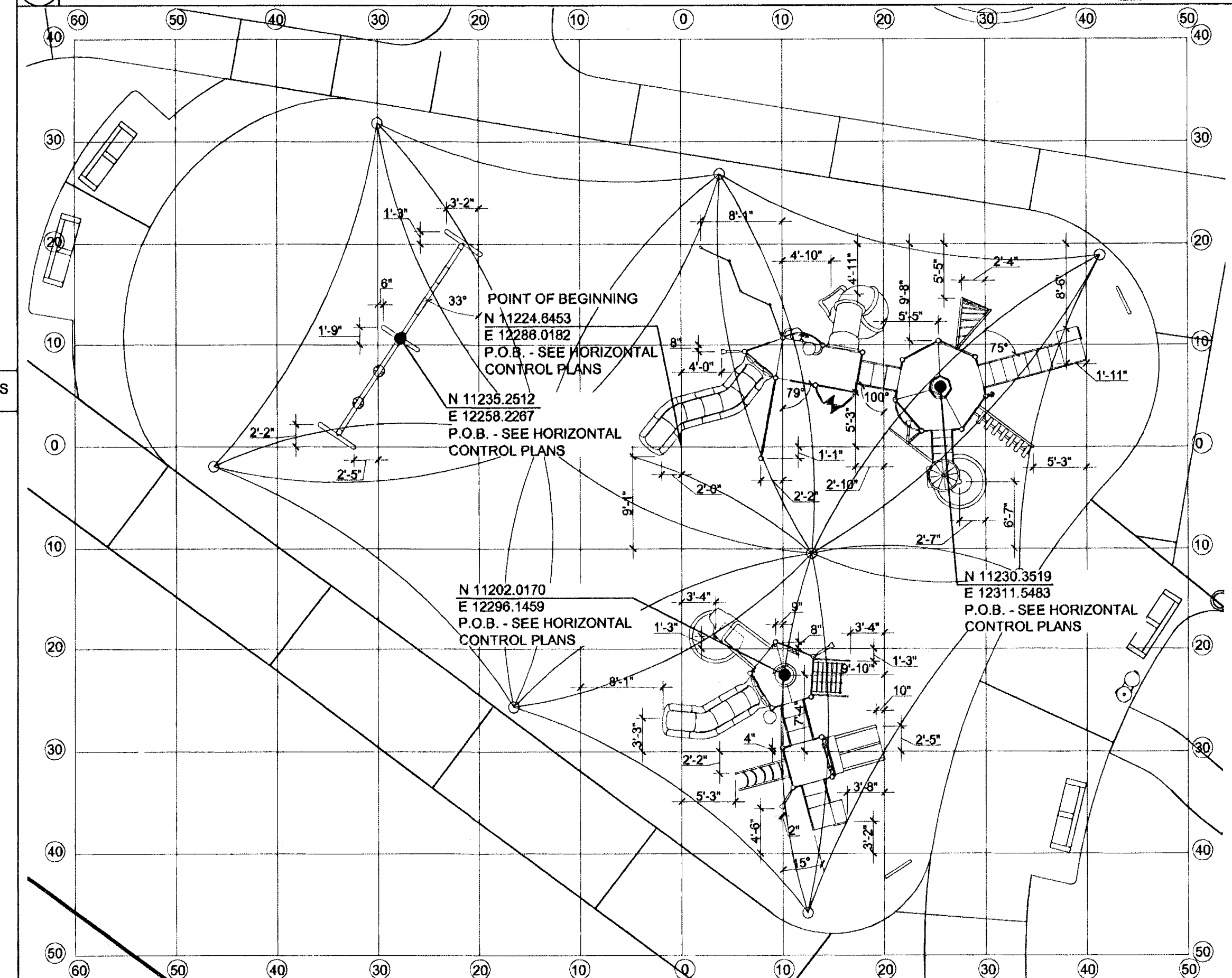

- LAYOUT NOTES:
- CONTRACTOR SHALL LAYOUT ALL EQUIPMENT AND VERIFY THAT ALL SAFETY ZONES SPECIFIED BY MANUFACTURER ARE MET.
 - ALL EQUIPMENT IS LAID OUT BY A 10' X 10' GRID. REFER TO HORIZONTAL CONTROL PLAN FOR LAYOUT OF TOTLOT PERIMETER AND POINT OF BEGINNING (P.O.B.) FOR EQUIPMENT.
 - SHOULD ANY DISCREPANCIES EXIST, NOTIFY CONSTRUCTION PROJECT REPRESENTATIVE.
 - CONTRACTOR TO FIELD VERIFY LOCATION OF UNDERGROUND SEWER LINE. VERIFY THAT NO POST OR FOOTINGS WILL DAMAGE SEWER LINE. IF USING ANY ALTERNATE SHADE EQUIPMENT OR PLAY EQUIPMENT VERIFY THAT POST AND/OR FOOTINGS DO NOT DAMAGE SEWER LINE.

2 PLAY EQUIPMENT DIMENSION PLAN

SCALE: 1" = 10'-0"

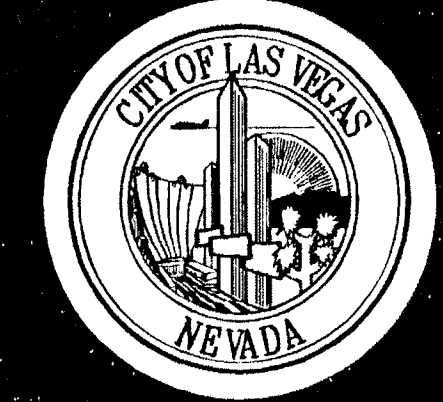

REVISIONS

CONSULTANT

DATE

SCALE

SHEET NO.

CITY DRAW NO.

DATE

SCALE

SHEET NO.

CITY DRAW NO.

DATE

SCALE

SHEET NO.

CITY DRAW NO.

DATE

SCALE

SHEET NO.

CITY DRAW NO.

DATE

SCALE

SHEET NO.

CITY DRAW NO.

DATE

SCALE

SHEET NO.

CITY DRAW NO.

DATE

SCALE

SHEET NO.

CITY DRAW NO.

DATE

SCALE

SHEET NO.

CITY DRAW NO.

DATE

SCALE

SHEET NO.

CITY DRAW NO.

DATE

SCALE

SHEET NO.

CITY DRAW NO.

DATE

SCALE

SHEET NO.

CITY DRAW NO.

DATE

SCALE

SHEET NO.

CITY DRAW NO.

DATE

SCALE

SHEET NO.

CITY DRAW NO.

DATE

SCALE

SHEET NO.

CITY DRAW NO.

DATE

SCALE

SHEET NO.

CITY DRAW NO.

DATE

SCALE

SHEET NO.

CITY DRAW NO.

DATE

SCALE

SHEET NO.

CITY DRAW NO.

DATE

SCALE

SHEET NO.

CITY DRAW NO.

DATE

SCALE

SHEET NO.

CITY DRAW NO.

DATE

SCALE

SHEET NO.

CITY DRAW NO.

DATE

SCALE

SHEET NO.

Cardno WRG
LAS VEGAS
1069 JEFFREYS ST., HENDERSON, NV 89002
TEL: (702) 960-5500 FAX: (702) 960-9305
www.cardnogr.com
PLANNERS - ENGINEERS - LANDSCAPE ARCHITECTS - SURVEYORS

SANDHILL OWENS PARK & TRAILHEAD
LAS VEGAS, NEVADA

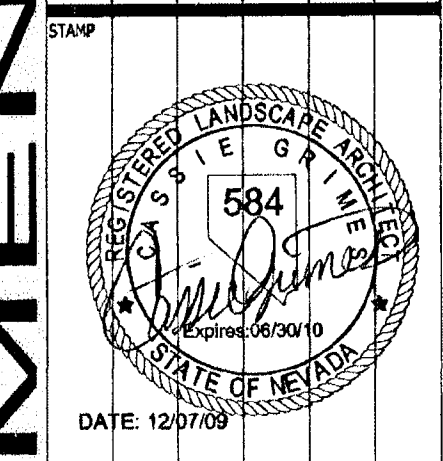

OWNER: CITY OF LAS VEGAS
DEPARTMENT OF PUBLIC WORKS
CAPITAL PROJECT MANAGEMENT SECTION

400 EAST STEWART AVENUE LAS VEGAS, NEVADA 89101 PHONE: (702) 229-5535 FAX: (702) 388-4848 TDD: (702) 388-9108
DRAWN: CCG/RL
FILE: 03/2007/97.01
DATE: 12-07-2009
SCALE: AS NOTED
SHEET NO: 08.1534.1.1
CITY DRAW NO: 008.104
SHEET NO: L1.05

100% SUBMITTAL

DEPARTMENT OF PUBLIC WORKS

SITE DETAILS

12-21-10