

A. REAR YARD DOUBLE WALL SECTION
NOT TO SCALE

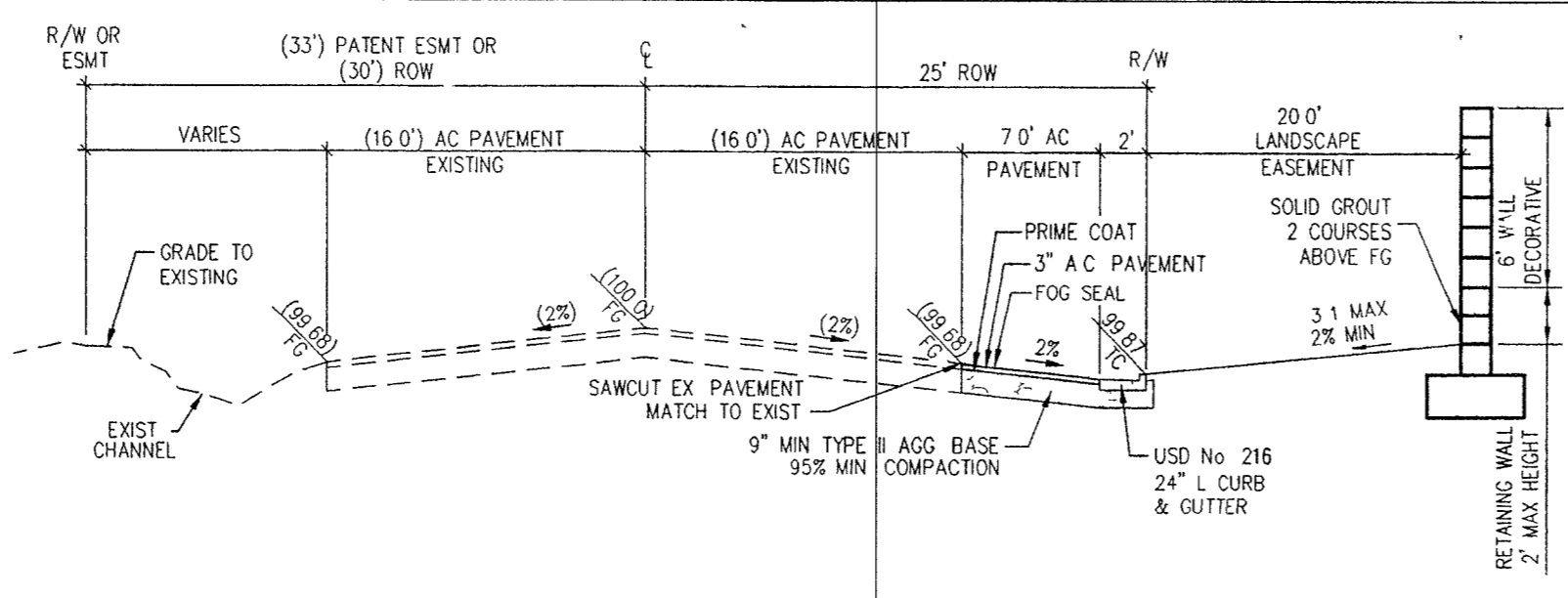

F. SEVERENCE LANE MINOR RESIDENTIAL COLLECTOR SECTION
NOT TO SCALE (PUBLIC STREET PER CCAUSD #208 1 ALT (MOD))

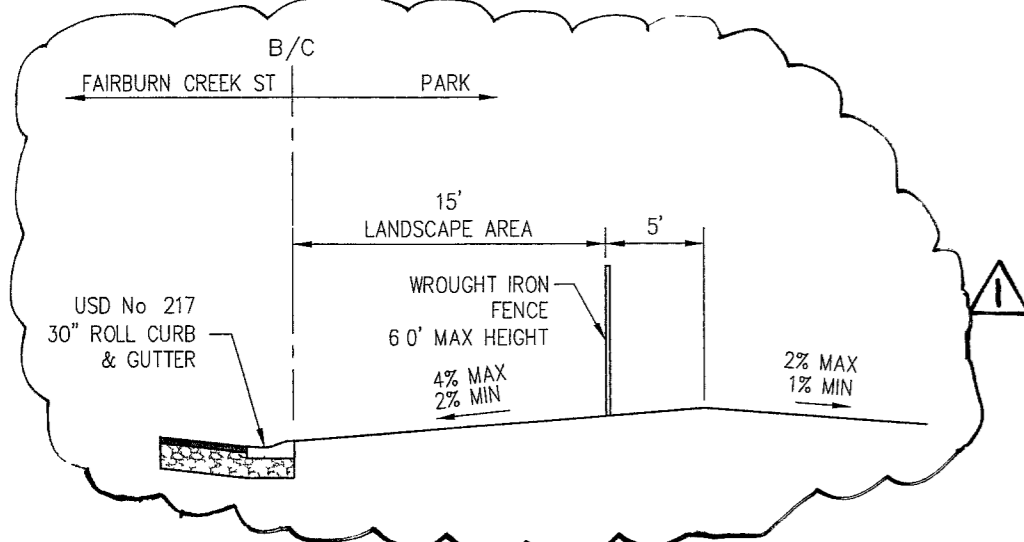

B. PARK LANDSCAPE SECTION
NOT TO SCALE

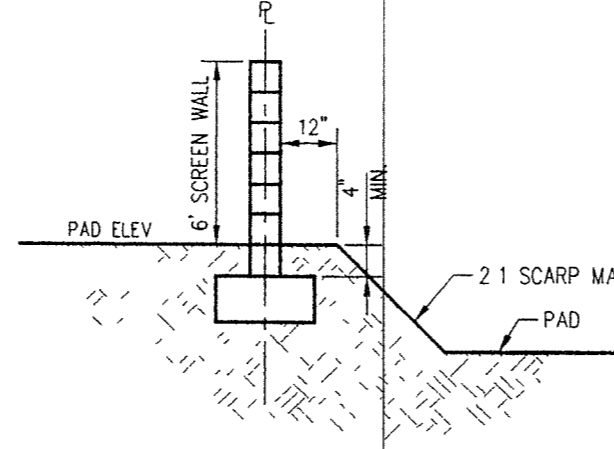

G. SIDE AND REAR YARD WALL SECTION
NOT TO SCALE

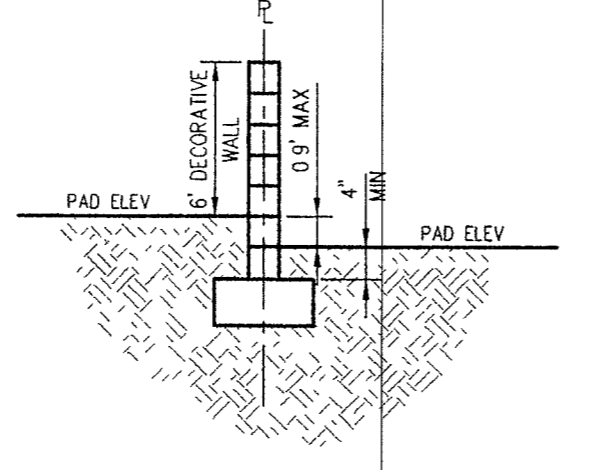
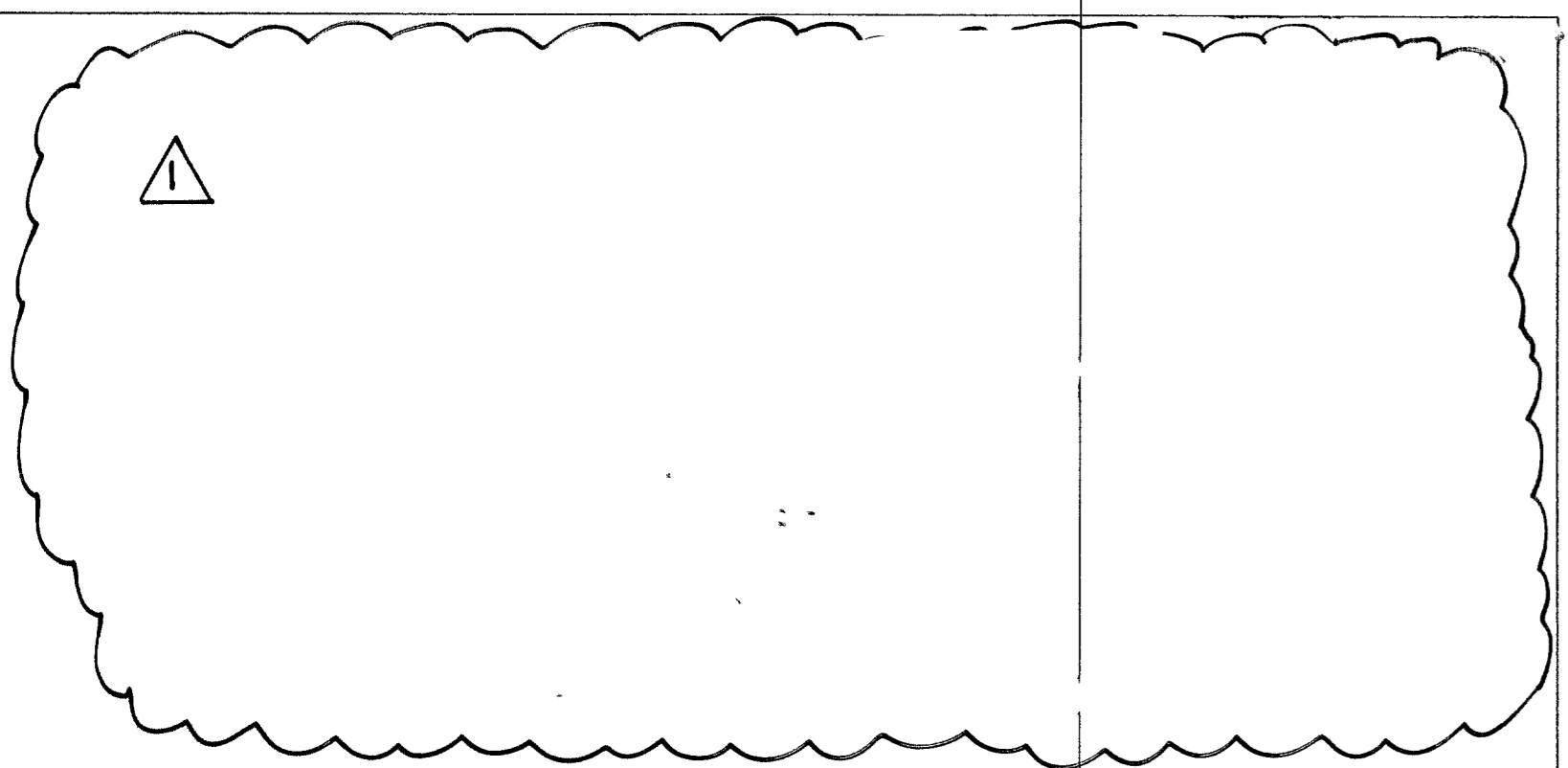

H. SIDE AND REAR YARD WALL SECTION
NOT TO SCALE

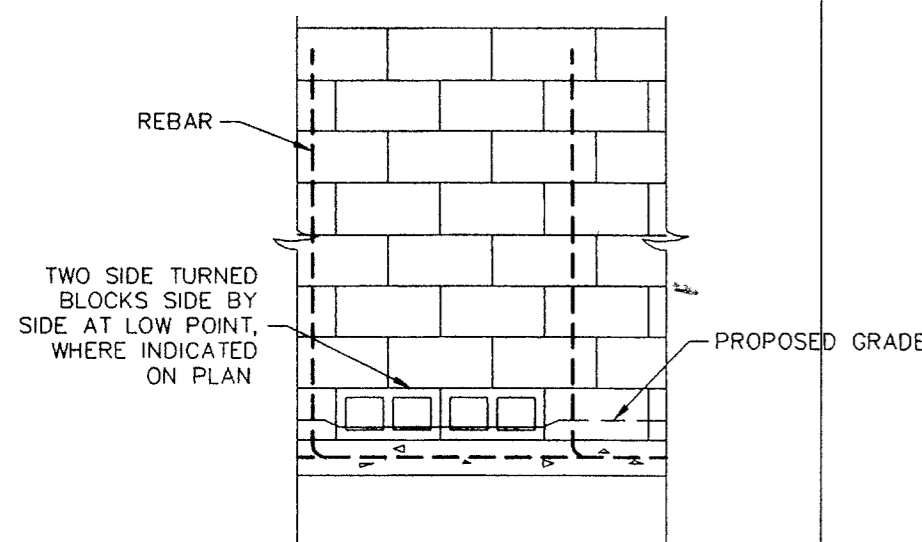

D. TYPICAL SIDE TURNED BLOCK DETAIL
NOT TO SCALE

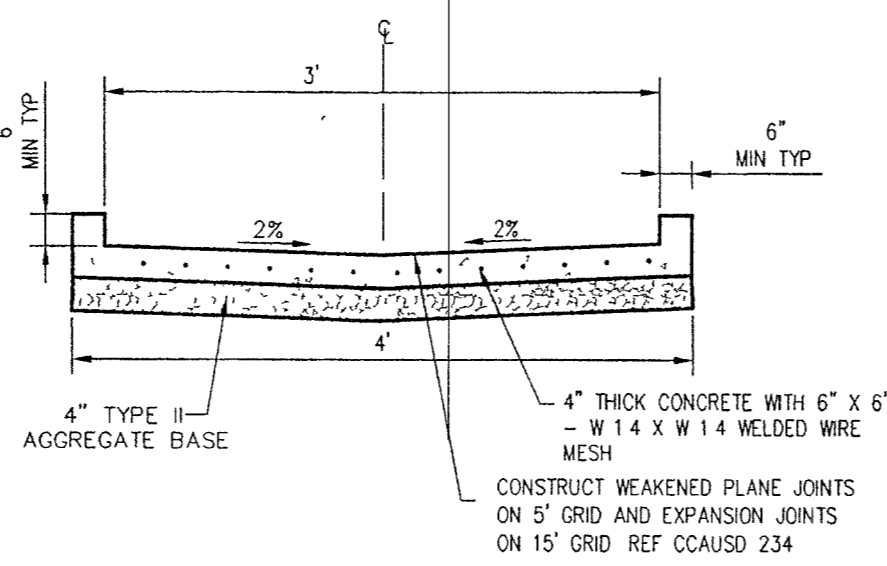

J. GENERAL DRAINAGE CHANNEL SECTION
NOT TO SCALE

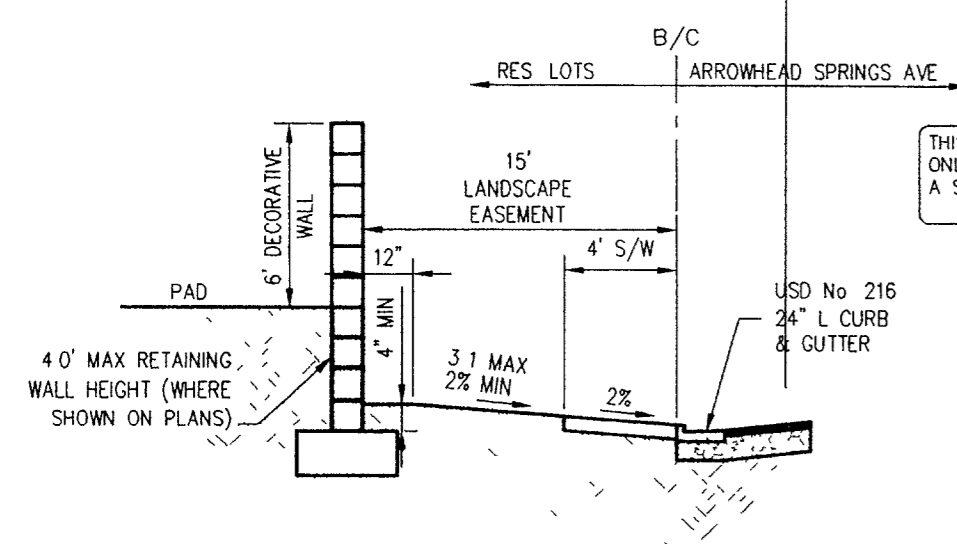

E. PERIMETER WALL SECTION
NOT TO SCALE

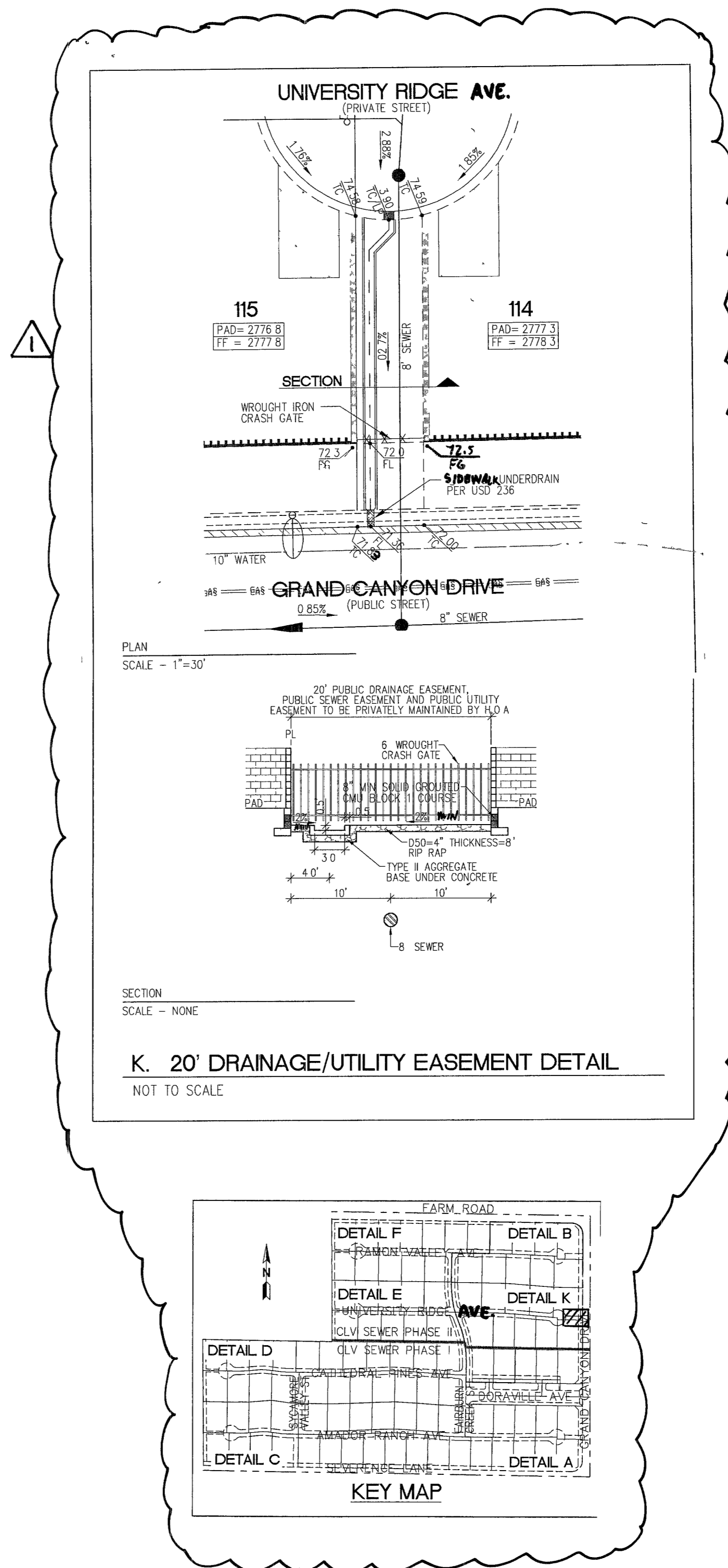

K. 20' DRAINAGE/UTILITY EASEMENT DETAIL
NOT TO SCALE

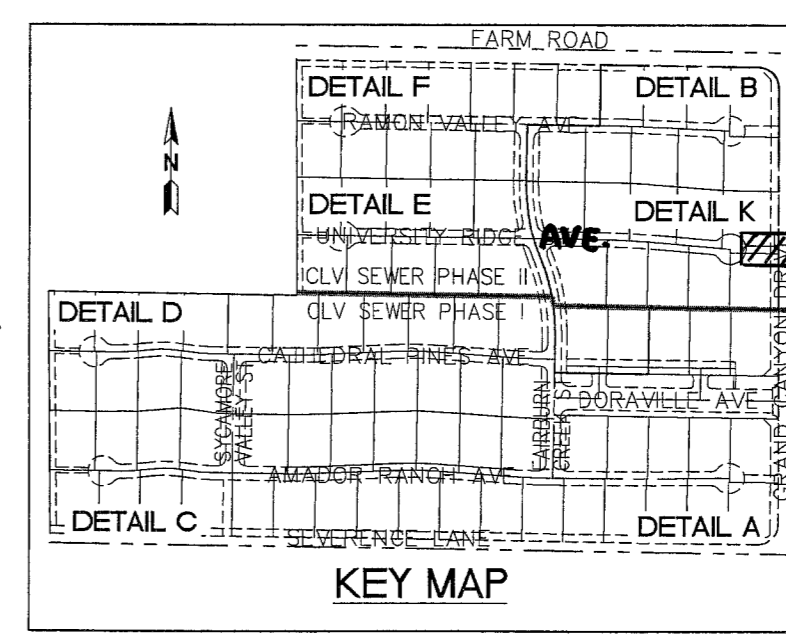

S-I-G
SLATER
HANIFAN
GROUP
CONSULTING ENGINEERS & PLANNERS
5740 S. ARVILLE STREET #216, LAS VEGAS, NV 89118
PHONE (702) 284-5300 FAX (702) 284-5399

NO.	DESCRIPTION	DATE	BY	APP.
1	REVISED DETAIL, ADDED KEY MAP - REMOVED DETAIL	4/19/06	DMB	

CLARK COUNTY, NEVADA

PINNACLE HOMES
SABLE CREEK
CROSS SECTIONS AND DETAILS

SECTION 18
TOWNSHIP 19 SOUTH
RANGE 60 EAST, MDM

DATE: 06/20/05
DRAFTER: DMB
DESIGNER: DMB
CHECKED: TJS

PROJECT NO.
PIN0402-001

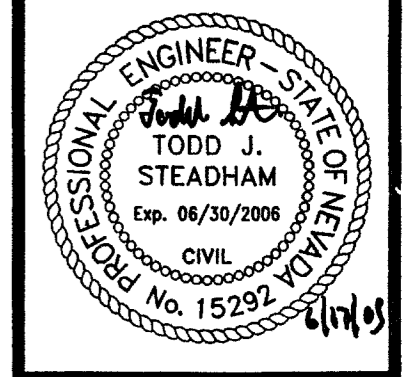

D-6
SHEET 42 OF 44
CLV DWG #3071930
CC HTE# 05-7995

REV. 1

File: J:\VEN0402-50cc\Draw\Impco\PIN0402-DETAIL.dwg, Jan 20, 2005 - 13:42

81769 Umm 92148