

**LEGEND**

|            |                        |          |                            |
|------------|------------------------|----------|----------------------------|
| 1          | LOT NUMBER             | 57.1     | ROUGH GRADE ELEVATION      |
| 1          | BLOCK NUMBER           | 57.10    | GRADE BREAK                |
| 59.0       | PAD ELEVATION          | TC OR FG | 2:1 SCARP                  |
| 59.0       | EXISTING PAD ELEVATION | 56       | EXISTING CONTOUR           |
| 59.0       | FUTURE PAD ELEVATION   | 61.1     | TOP OF FOOTING ELEV.       |
| 57.10 / FG | FINISHED GRADE         | ---      | UNIT BOUNDARY              |
| (57.10)    | EXISTING ELEVATION     | ---      | SHEET MATCH LINE           |
| (57.10)    | FUTURE ELEVATION       | ---      | SCREEN WALL                |
|            |                        | -----    | VILLAGE WALL               |
|            |                        | △4       | NUMBER OF COURSES RETAINED |

I certify that this grading plan conforms to the approved drainage study for this site on file at the City of Las Vegas

*Milo L. Mierzich* (DATE) 7/2/98  
MILO L. MERZICH, P.E. Lic. No. 12846

- GRADING NOTES**
- INDICATED GRADES OTHER THAN T.C., F.G. & GUTTER F.L. ARE ROUGH GRADES. (0.3' LOWER THAN FINISHED GRADE).
  - THE ROUGH GRADING PLANS SHALL BE ON THE JOB SITE AT ALL TIMES. THE ROUGH GRADING SHALL BE FINISHED IN CONFORMANCE WITH THE LINES AND GRADES SHOWN ON THE PLANS. THE GRADING QUANTITIES ARE BASED ON THE ELEVATION AND DETAILS SHOWN ON THE PLANS. ANY DEVIATIONS FROM THE PLANS WILL RESULT IN QUANTITY CHANGES.
  - CARE SHALL BE EXERCISED IN GRADING CORNER LOTS.
  - ROUGH PAD ELEVATIONS SHALL BE GRADED TO WITHIN 0.3' OF THE PAD ELEVATIONS SHOWN ON THE PLANS.
  - SOILS REPORT PREPARED BY WESTERN TECHNOLOGIES INC., PROJECT NO. 41280019, DATED FEBRUARY 17, 1998.
  - THIS PARCEL DEVELOPER IS RESPONSIBLE FOR ALL FILL MATERIAL, GRADING AND RETAINING WALLS WITHIN SUMMERLIN'S H.O.A. COMMON LOT.
  - ROUGH GRADING TO NAPA HILLS BY LEWIS HOMES, UNITS ONE AND TWO MUST BE DONE SIMULTANEOUSLY.
  - CONSTRUCTION EASEMENTS FOR OFFSITE GRADING MUST BE GRANTED BY OWNERS OF ADJACENT PROPERTIES PRIOR TO CONSTRUCTION.

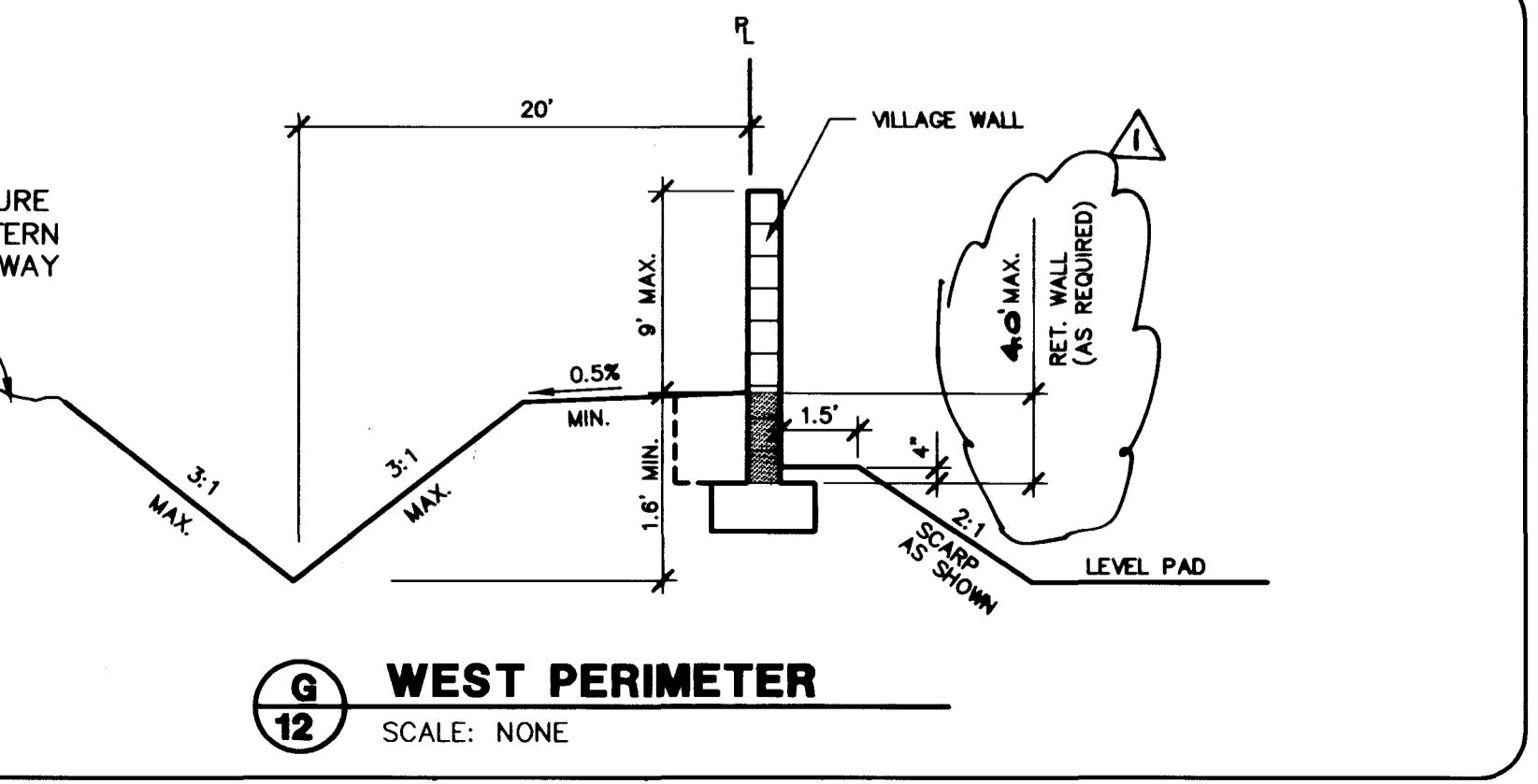
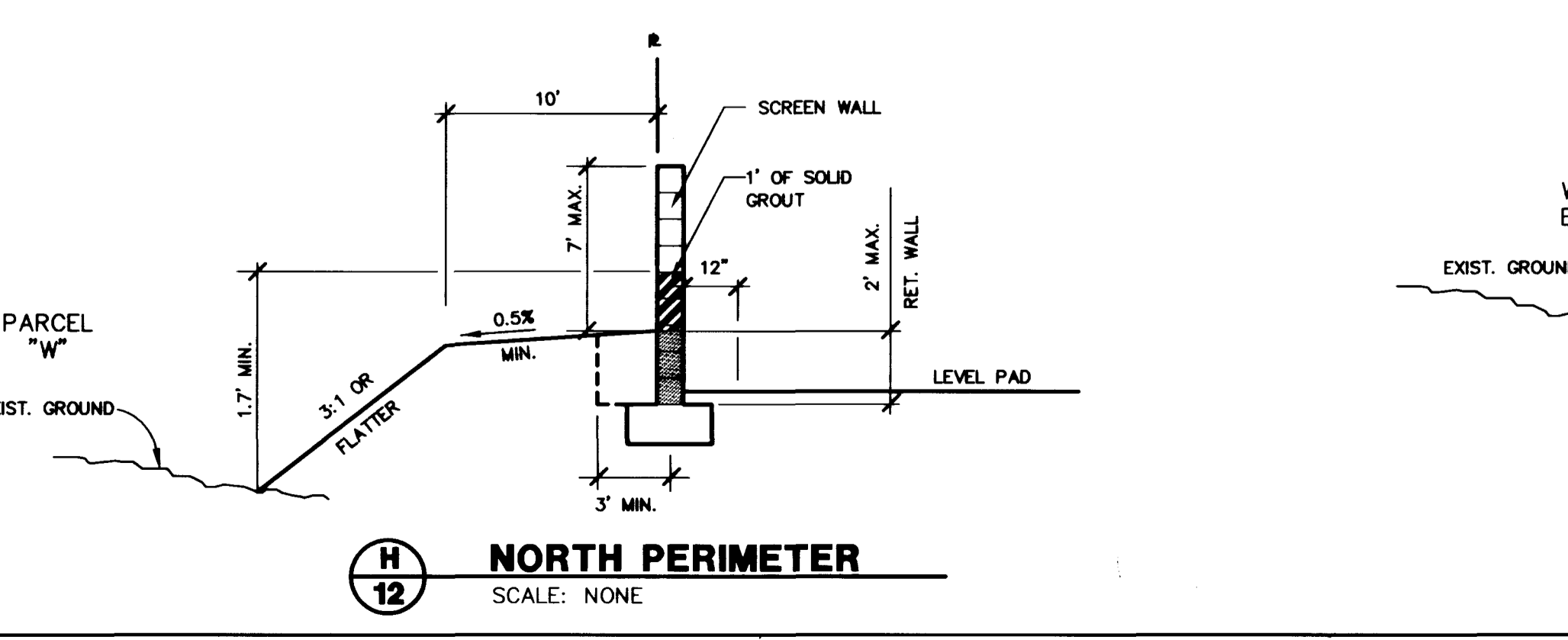
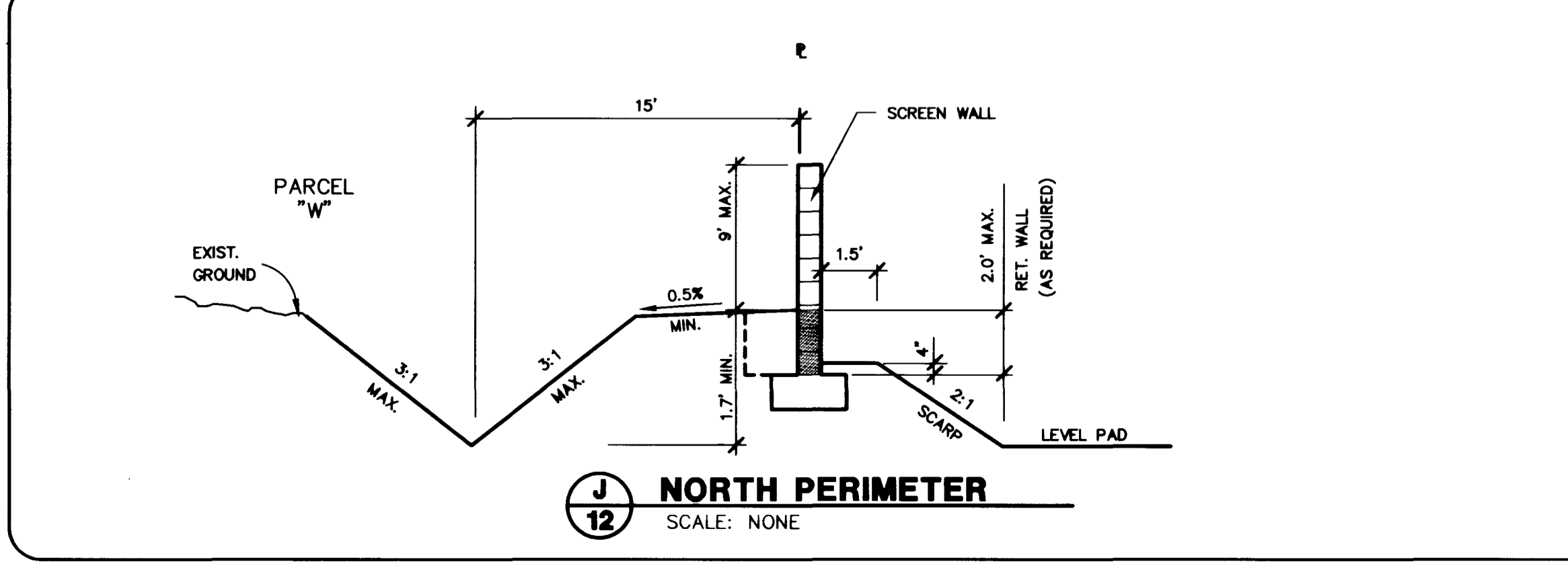
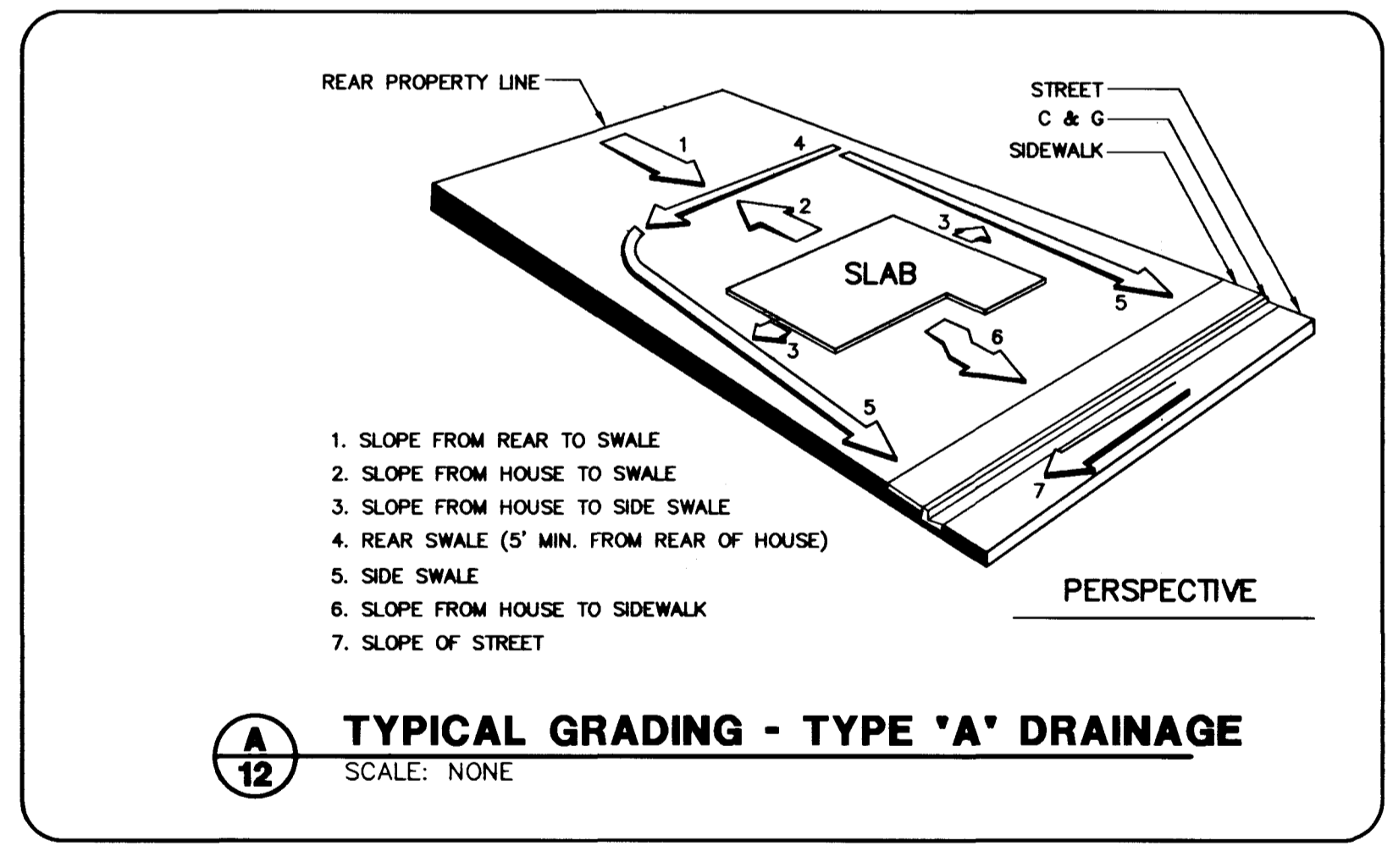

RECOMMENDED

REVISIONS

| NO. | DATE   | DESCRIPTION         |
|-----|--------|---------------------|
| 1   | 7/2/98 | REV. RETAINING WALL |

REGISTERED PROFESSIONAL ENGINEER STATE OF NEVADA  
MILO L. MERZICH  
CIVIL  
LICENSE NO. 12846  
P.E. NO. 12846

**G.C. WALLACE, INC.**  
Engineering/Architecture  
1555 SOUTH RAINBOW BLVD./LAS VEGAS, NEVADA 89102

**NAPA HILLS BY LEWIS HOMES**  
UNIT 3  
GRADING & BLOCK WALL DETAILS

SHEET **12**  
OF 12 SHEETS

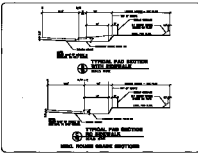
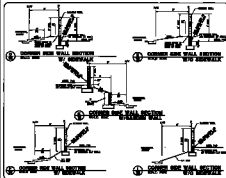

**LEGEND**

|  |        |  |        |
|--|--------|--|--------|
|  | NO. 10 |  | NO. 10 |
|  | NO. 10 |  | NO. 10 |
|  | NO. 10 |  | NO. 10 |
|  | NO. 10 |  | NO. 10 |
|  | NO. 10 |  | NO. 10 |
|  | NO. 10 |  | NO. 10 |
|  | NO. 10 |  | NO. 10 |
|  | NO. 10 |  | NO. 10 |
|  | NO. 10 |  | NO. 10 |
|  | NO. 10 |  | NO. 10 |

I hereby certify that the drawings and specifications for the project described herein were prepared by me or under my direct supervision and that I am a duly Licensed Professional Engineer in the State of California.

*John J. ...*

NO. 10 ...

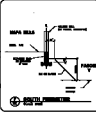
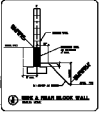
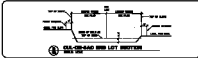
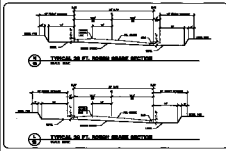

- REVISIONS**
1. REVISED DRAWING TO SHOW ...
  2. REVISED DRAWING TO SHOW ...
  3. REVISED DRAWING TO SHOW ...
  4. REVISED DRAWING TO SHOW ...
  5. REVISED DRAWING TO SHOW ...
  6. REVISED DRAWING TO SHOW ...
  7. REVISED DRAWING TO SHOW ...
  8. REVISED DRAWING TO SHOW ...
  9. REVISED DRAWING TO SHOW ...
  10. REVISED DRAWING TO SHOW ...

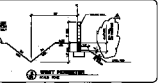
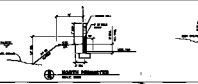
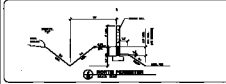
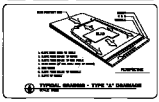

C.C. WILKINSON, INC.  
 12