

TYPICAL BUILDING SECTION - TYPE "1"
SCALE 1"=10'

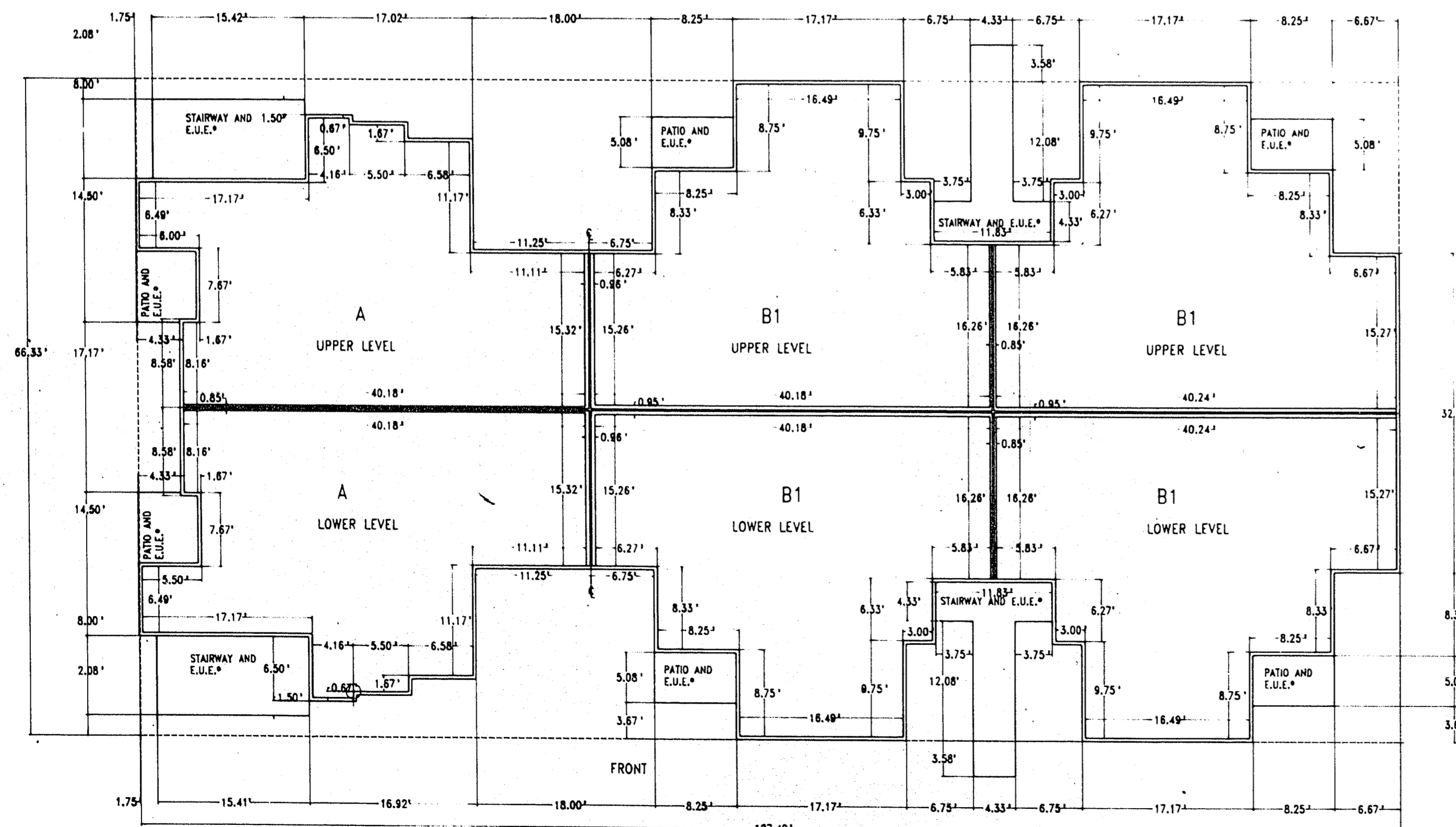

TYPICAL BUILDING PLAN - TYPE "1"
SCALE 1"=10'

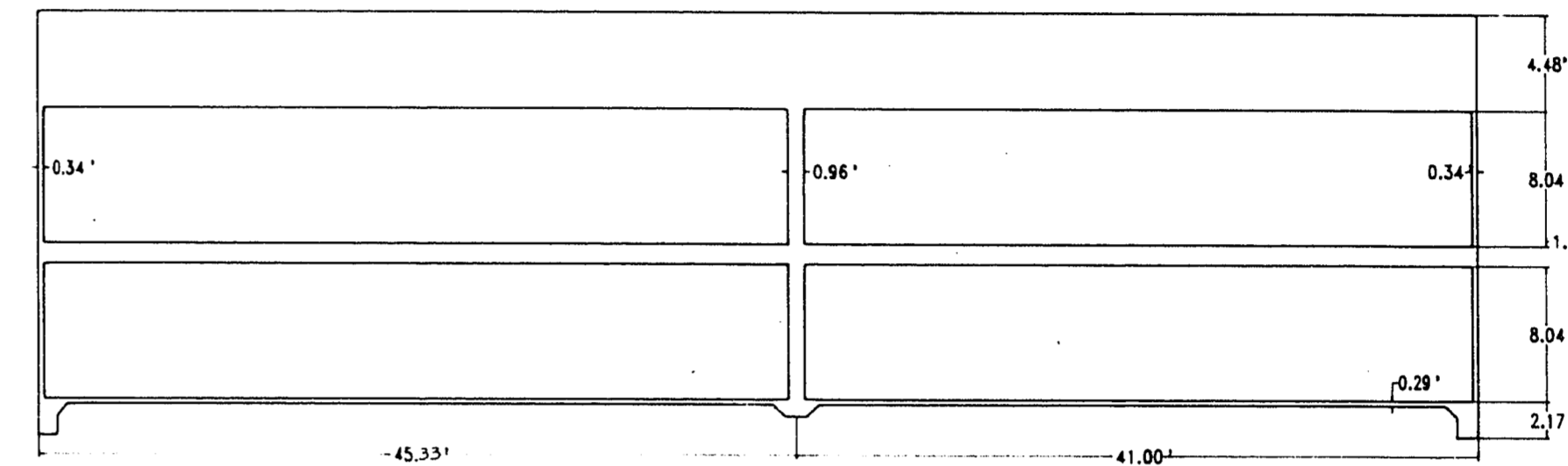

TYPICAL BUILDING SECTION - TYPE "2"
SCALE 1"=10'

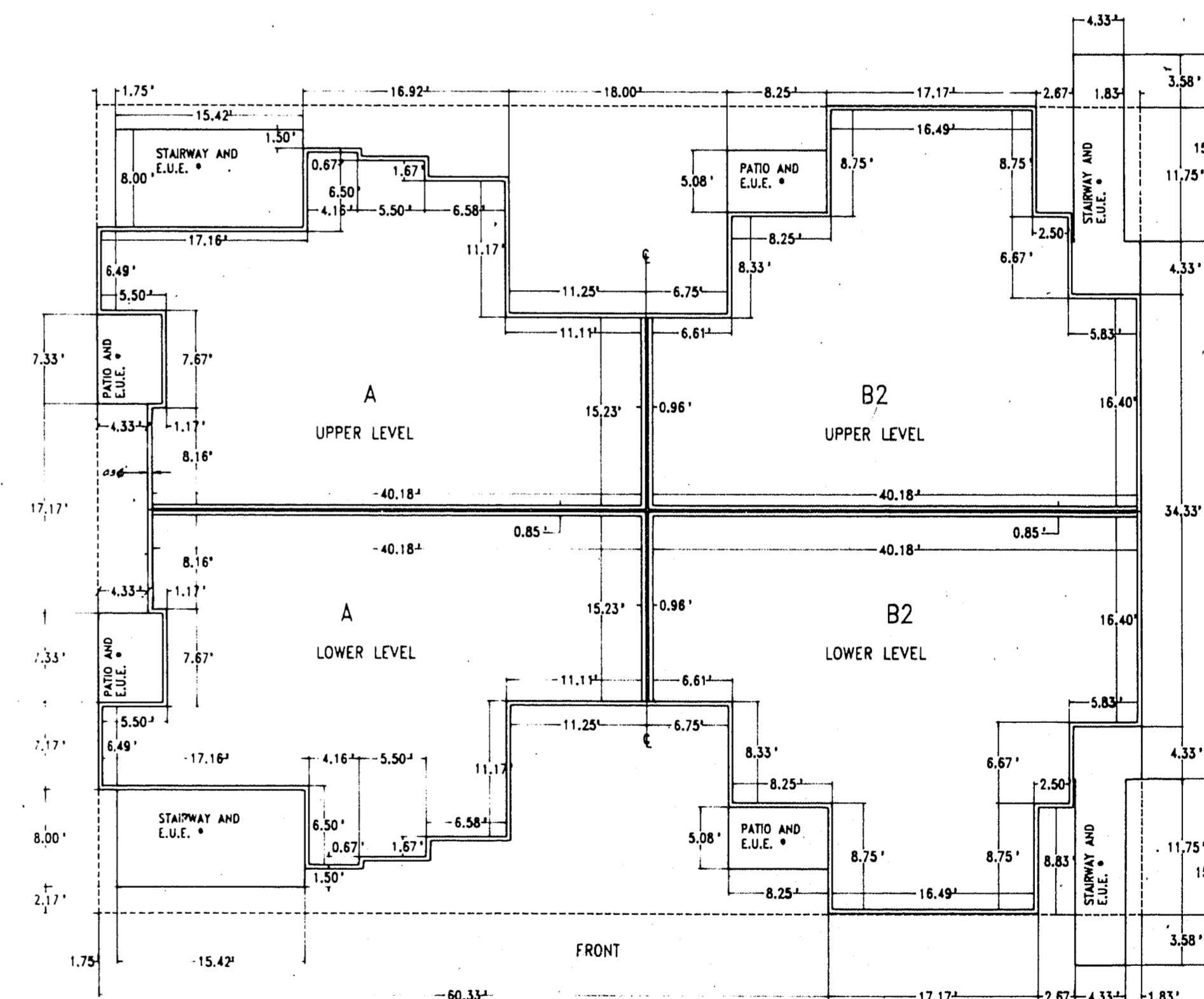

TYPICAL BUILDING PLAN - TYPE "2"
SCALE 1"=10'

* - E.U.E. DENOTES EXCLUSIVE USE EASEMENT, TYPICAL

OFFICIAL PLAT PACIFIC HARBORS V A CONDOMINIUM SUBDIVISION A PORTION OF THE W 1/2 NW 1/4, SEC. 22, T. 20S., R. 60E., M.D.M., CITY OF LAS VEGAS CLARK COUNTY NEVADA	
SEA ENGINEERS/PLANNERS	JOB NO. 2-384-111 DESIGNED BY DRAWN BY HP 1000 AB00 COMP. CHECKED DATE JUNE, 1989 SHEET NO. 3 OF 4 SHEETS
	SPARKS, NEVADA LAS VEGAS, NEVADA PHOENIX, ARIZONA