

Avoid cutting underground utility lines. It's costly.
 Call before you Dig.
 1-800-227-2600

BASIS OF BEARINGS
 S 88 51'13" E, BEING THE SOUTH LINE OF THE SW 1/4 SECTION 8, T.21S., R.60E., M.D.M., AS SHOWN IN BOOK 73, PAGE 90, OF PLATS.

BENCHMARK
 CITY OF LAS VEGAS BENCH MARK # 1LV10 7SES BEING A RIVET AND PLATE IN THE TOP OF CURB NW RETURN OF DESERT INN ROAD AND FORT APACHE ROAD. ELEV=832.1847 METERS (2730.26 FEET) NAVD 88

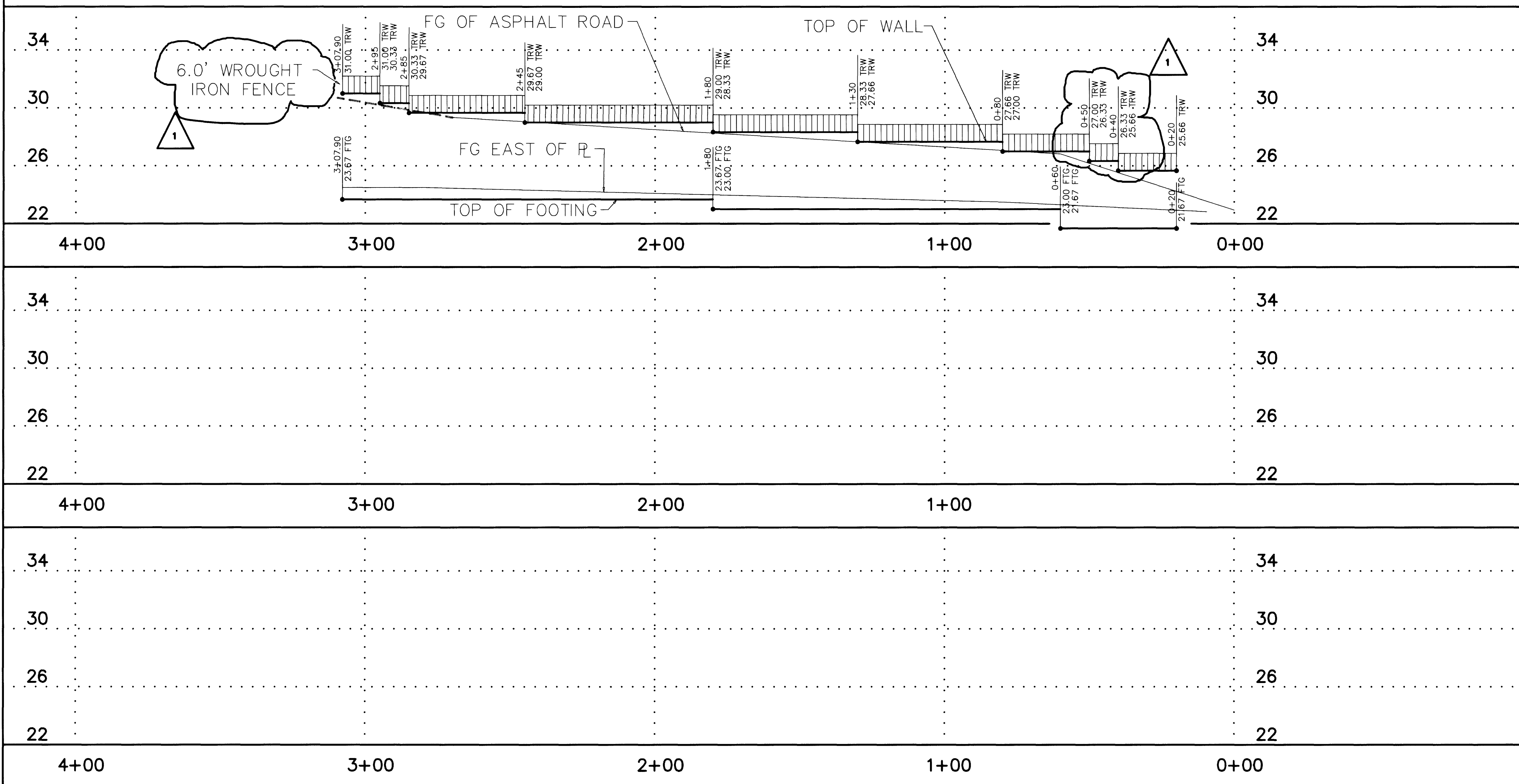
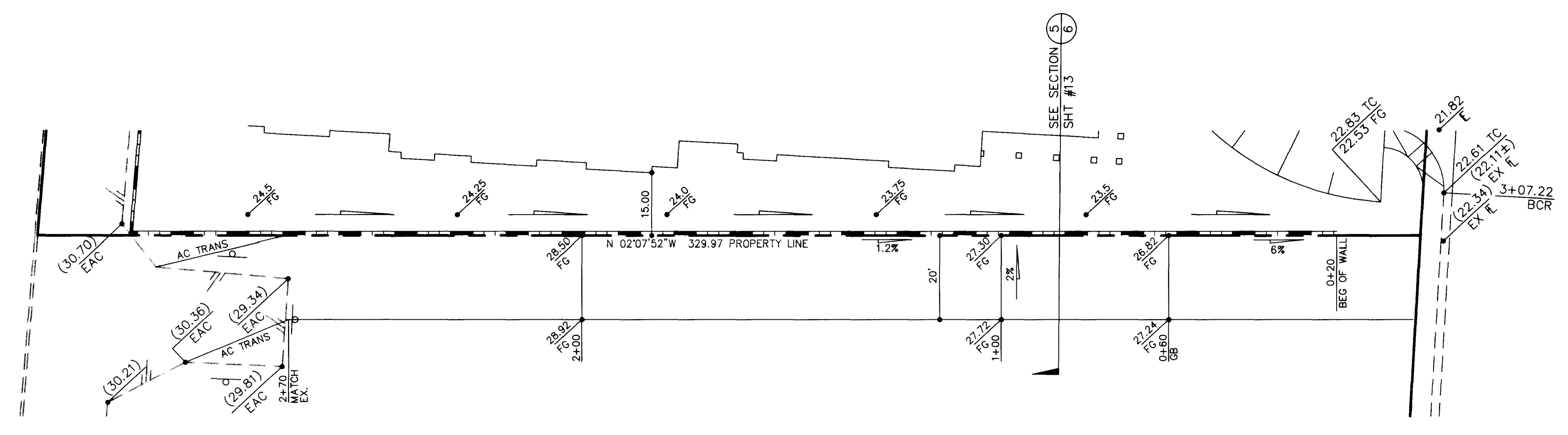
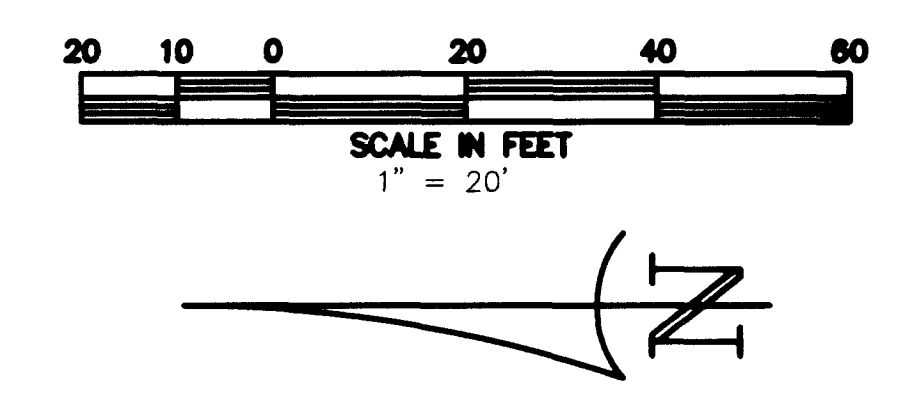

GALLAHER CONSTRUCTION, INC. 9066 BROOKS ROAD SOUTH WINDSOR, CA, 95492 (707) 836-0473		ADD WROUGHT IRON FENCE REV'D DATE BY
DUNNAM CIVIL ENGINEERS 3305 SPRING MOUNTAIN ROAD SUITE B2 LAS VEGAS, NV 89102 (702) 367-0588 (702) 367-8145 FAX		REV'D DATE BY
SHEET: RETAINING WALL PLAN & PROFILE TITLE: OAKMONT RETIREMENT COMMUNITY #4		SCALE: 1" = 20' HOR. 1" = 4' VERT.
DRAWN BY:	DESIGNED BY:	CHECKED BY:
PROJECT NO.: GALL.D3C		
SHEET SD3 11 OF 13 SHEETS DRAWING NO. 107-V2893		

14654

GALL 3SD3
 1" = 20'

Re-plot



1-20-27-368
 before
 Call
 1-20-27-368

BASIS OF BEARINGS
 ALL BEARINGS TO BE USED IN THIS
 PLAN SHALL BE TO THE CENTER OF THE
 BENCHMARK
 BENCHMARK
 THE POINT OF INTERSECTION OF THE
 CENTERLINE OF THE ROAD AND THE
 CENTERLINE OF THE RAILROAD TRACKS
 AT THE POINT OF INTERSECTION OF THE
 CENTERLINE OF THE ROAD AND THE
 CENTERLINE OF THE RAILROAD TRACKS

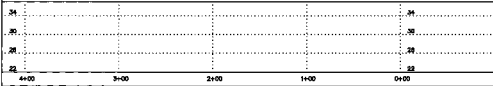
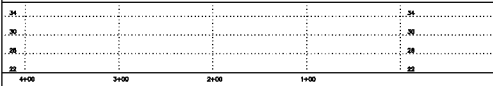
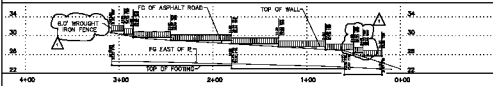

GALLAGHER CONSTRUCTION, INC. 1000 10th St. N.W. ALBANY, O.H. 44604	
DRAWING NO. _____ SHEET NO. _____	PROJECT NO. _____ SHEET NO. _____
RETAINING WALL PLAN & PROFILE GARHWITZ RESIDENT COMMUNITY #4	
DATE: _____ DRAWN BY: _____ CHECKED BY: _____ SCALE: _____ PROJECT: _____	