

Avoid cutting underground utility lines. It's costly.  
 Call before you Dig.  
 1-800-227-2600

**BASIS OF BEARINGS**  
 S 88 51'13" E, BEING THE SOUTH LINE OF THE SW 1/4 SECTION 8, T.21S., R.60E., M.D.M., AS SHOWN IN BOOK 73, PAGE 90, OF PLATS.

**BENCHMARK**  
 CITY OF LAS VEGAS BENCH MARK # 1LV10 7SES BEING A RIVET AND PLATE IN THE TOP OF CURB NW RETURN OF DESERT INN ROAD AND FORT APACHE ROAD. ELEV=832.1847 METERS (2730.26 FEET) NAVD 88

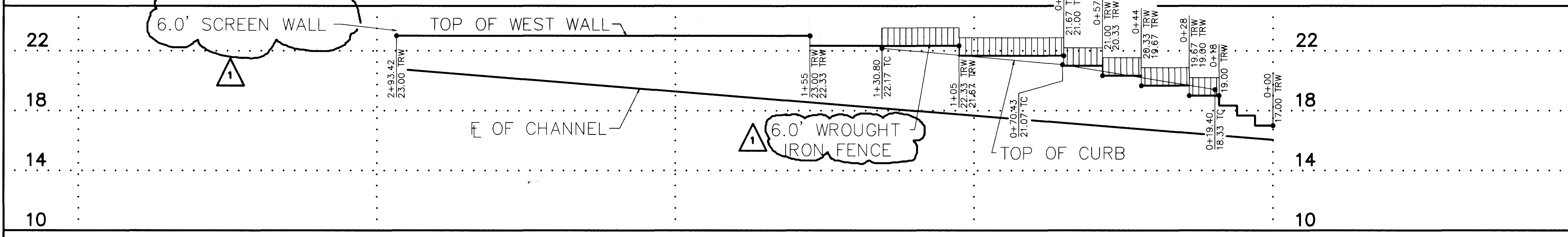
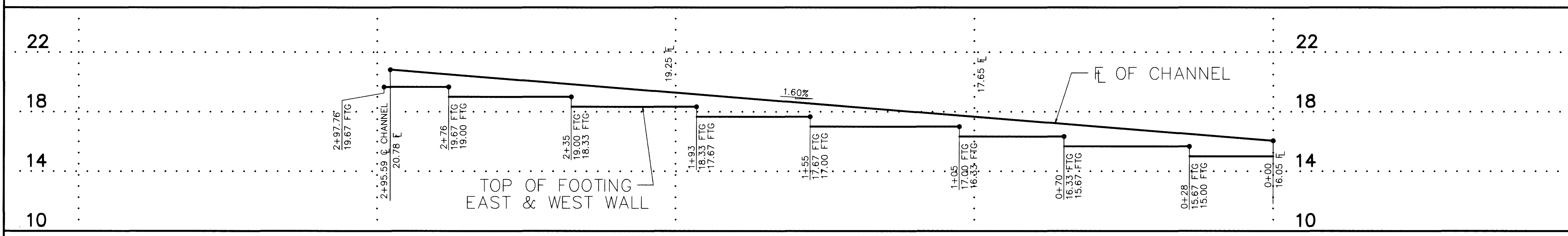
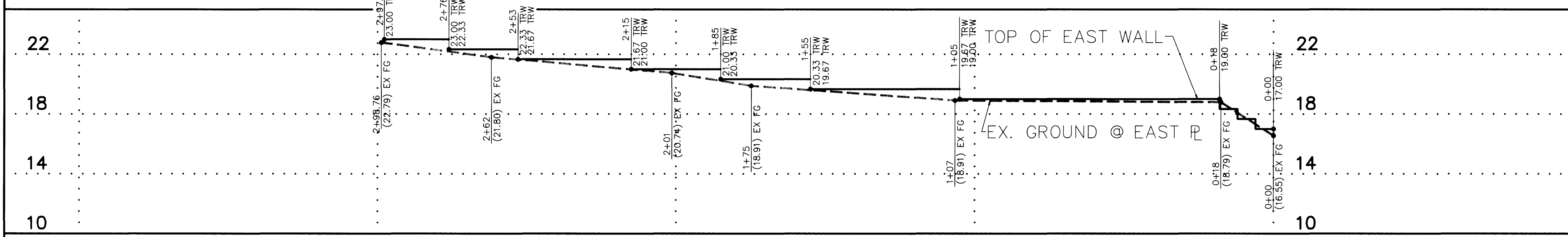
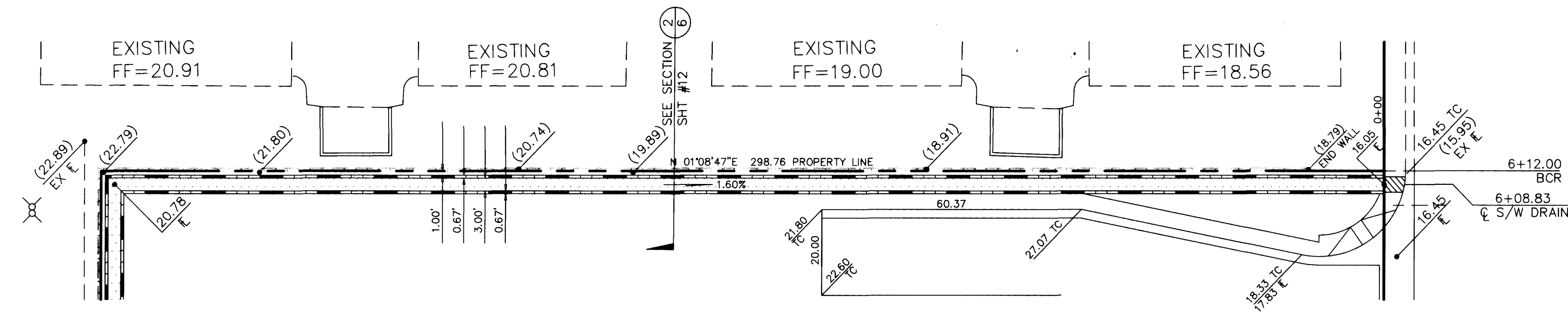
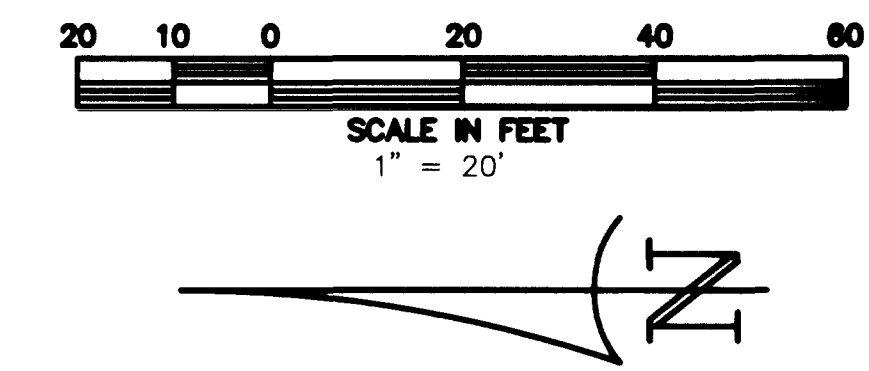

GALLAHER CONSTRUCTION, INC.  
 9066 BROOKS ROAD SOUTH  
 WINDSOR, CA. 95492  
 (707) 836-0473

DUNNAM CIVIL ENGINEERS  
 3305 SPRING MOUNTAIN ROAD, SUITE 82  
 LAS VEGAS, NV 89102  
 (702) 367-0588  
 (702) 367-8145 FAX

CHANNEL PLAN & PROFILE

OAKMONT RETIREMENT COMMUNITY #4

DRAWN BY:  
 DESIGNED BY:  
 CHECKED BY:  
 PROJECT NO.:  
 SCALE: 1" = 4' VERT.

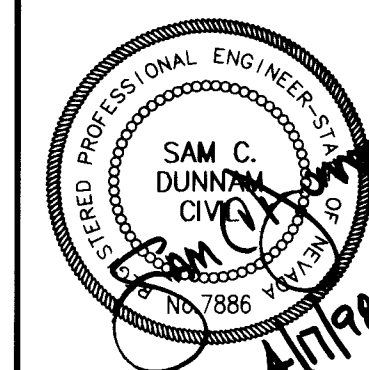

SHEET SD1  
 9 OF 13 SHEETS

DRAWING NO. 107-V2893

1" = 20' H  
 1" = 100' V  
 80' - 0"

**BASIS OF BEARINGS**  
 1947  
 1948  
 1949  
 1950  
 1951  
 1952  
 1953  
 1954  
 1955  
 1956  
 1957  
 1958  
 1959  
 1960  
 1961  
 1962  
 1963  
 1964  
 1965  
 1966  
 1967  
 1968  
 1969  
 1970  
 1971  
 1972  
 1973  
 1974  
 1975  
 1976  
 1977  
 1978  
 1979  
 1980  
 1981  
 1982  
 1983  
 1984  
 1985  
 1986  
 1987  
 1988  
 1989  
 1990  
 1991  
 1992  
 1993  
 1994  
 1995  
 1996  
 1997  
 1998  
 1999  
 2000  
 2001  
 2002  
 2003  
 2004  
 2005  
 2006  
 2007  
 2008  
 2009  
 2010  
 2011  
 2012  
 2013  
 2014  
 2015  
 2016  
 2017  
 2018  
 2019  
 2020

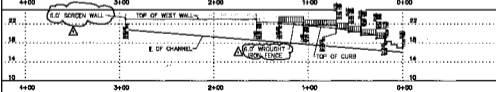
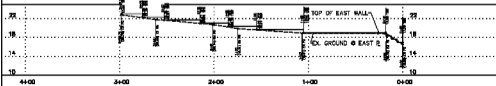

BALLANCE CONSTRUCTION, INC. 1000 W. 10th St. DENVER, CO. 80202	
CHANNEL PLAN & PROFILE PROJECT NO. 1000	CIVIL ENGINEER PROJECT NO. 1000
DRAWN BY: [Name] CHECKED BY: [Name]	DATE: 2-2-66

Re-plot