

### GRADING NOTES

- CONTRACTOR SHALL PROVIDE ALL NECESSARY HORIZONTAL AND VERTICAL TRANSITION BETWEEN NEW CONSTRUCTION AND EXISTING SURFACES TO PROVIDE FOR PROPER DRAINAGE AND OF PROGRESS AND ACCESS TO SAID CONSTRUCTION, EXTENT OF TRANSITIONS TO BE DETERMINED BY CITY ENGINEER.
- EXISTING UTILITIES ARE LOCATED ON PLANS FOR THE CONVENIENCE OF THE CONTRACTOR ONLY. THE CONTRACTOR SHALL BEAR FULL RESPONSIBILITY FOR THE PROTECTION OF UTILITIES AND THE ENGINEER BEARS NO RESPONSIBILITY FOR UTILITIES NOT SHOWN ON PLANS OR NOT IN THE LOCATION SHOWN ON THE PLANS.
- CONSTRUCTION TO BE PER UNIFORM STANDARD SPECIFICATIONS AND DRAWINGS: CLARK COUNTY, NEVADA, 1994 EDITION.
- USE TYPE V CLASS B CONCRETE IN ALL OFFSITE CONCRETE WORK.
- CHISEL S.W. & G WHERE SEWER, WATER & GAS LINES PASS UNDER THE CURB.
- THE CONTRACTOR SHALL TAKE ALL PRECAUTIONARY MEASURES NECESSARY TO PROTECT EXISTING IMPROVEMENTS, WHICH ARE TO REMAIN IN PLACE, FROM DAMAGE AND ALL SUCH IMPROVEMENTS OR STRUCTURES DAMAGED BY THE CONTRACTOR'S OPERATIONS SHALL BE REPAIRED OR RECONSTRUCTED SATISFACTORY TO THE OWNER AT THE EXPENSE OF THE CONTRACTOR.
- THE CONTRACTOR SHALL BE RESPONSIBLE FOR THE VERTICAL ADJUSTMENT OF ALL EXISTING MANHOLES, CLEANOUTS, VALVE BOXES AND STRUCTURES TO THE FINAL FINISH GRADES.
- CURBS AND GUTTERS WITH A GRADE OF LESS THAN FOUR TENTHS OF ONE PERCENT SHALL BE CONSTRUCTED BY FORMING. EACH JOINT SHALL BE CHECKED FOR GRADE PRIOR TO CONSTRUCTION AND WATER TESTED AS SOON AS POSSIBLE AFTER CONSTRUCTION.
- WHEELCHAIR RAMPS SHALL BE CONSTRUCTED AT ALL STREET INTERSECTIONS PER STANDARD DRAWINGS 110. EXACT LOCATION OF RAMP TO BE DETERMINED IN FIELD BY A COUNTY INSPECTOR.
- BEFORE ANY WORK IS STARTED IN THE RIGHT-OF-WAY, THE CONTRACTOR SHALL INSTALL ALL ADVANCE HAZARD SIGNS FOR THE CONSTRUCTION ZONE. THE CONTRACTOR SHALL INSTALL TEMPORARY STOP SIGNS AT ALL NEW STREET ENCROACHMENTS INTO EXISTING CITY STREETS IMMEDIATELY AFTER THE FIRST GRADING WORK IS ACCOMPLISHED, AND SHALL MAINTAIN SAID SIGNS UNTIL PERMANENT SIGNS ARE INSTALLED AS PER TRAFFIC ENGINEER.
- ALL CONSTRUCTION SIGNING, BARRICADES AND TRAFFIC DELINEATION SHALL CONFORM TO THE LATEST EDITION OF THE "NEVADA TRAFFIC CONTROL MANUAL".
- THE CONTRACTOR SHALL FOLLOW THE GUIDELINES AND REGULATIONS AS SET FORTH IN D.S.W.A. THE ENGINEER AND/OR OWNER SHALL NOT BE RESPONSIBLE FOR JOB SITE SAFETY PROCEDURE.
- CONSTRUCTION PLANS, STANDARD DRAWINGS AND UNIFORM STANDARD SPECIFICATIONS SHALL BE ON JOB SITE AT THE TIME OF CONSTRUCTION.
- THE SOIL ENGINEER SHOULD BE RETAINED TO PROVIDE "CONTINUOUS" SERVICES DURING GRADING AND FOUNDATION PHASES OF THE WORK. THESE SERVICES ARE TO OBSERVE COMPLIANCE WITH THE DESIGN CONCEPTS, SPECIFICATIONS OR RECOMMENDATIONS.
- THE CONTRACTOR SHALL SUBMIT A BARRICADE PLAN TO THE CITY PRIOR TO COMMENCEMENT OF OFFSITE CONSTRUCTION.
- THE QUANTITIES GIVEN IN THE DRAWINGS ARE APPROXIMATE ONLY, BEING GIVEN AS A BASIS FOR THE COMPARISON OF BIDS, AND THE ACTUAL AMOUNT OF WORK WILL CORRESPOND THEREWITH, BUT RESERVES THE RIGHT TO MAKE SUCH ALTERATIONS, DEVIATIONS, ADDITIONS TO OR OMISSIONS FROM THE PLANS AND SPECIFICATIONS, INCLUDING THE RIGHT TO INCREASE OR DECREASE THE QUANTITY OF ANY ITEM OR PORTION OF THE WORK OR TO OMIT ANY ITEM OR PORTION OF THE WORK, AS MAY BE DEEMED BY THE OWNER TO BE NECESSARY.

ANY SUCH CHANGES WILL BE SET FORTH IN A CONTRACT CHANGE ORDER WHICH WILL SPECIFY, IN ADDITION TO THE WORK TO BE DONE IN CONNECTION WITH THE CHANGE MADE, ADJUSTMENT OF CONTRACT TIME, IF ANY, AND THE BASIS OF COMPENSATION FOR SUCH WORK. A CONTRACT CHANGE ORDER WILL NOT BECOME EFFECTIVE UNTIL APPROVED BY THE OWNER.

17. THE BIDDER OR THE CONTRACTOR IS EXPECTED TO EXAMINE CAREFULLY THE SITE OF THE PROPOSED WORK, THE PROPOSED PLANS, AND SPECIFICATIONS BEFORE SUBMITTING A PROPOSAL. THE SUBMISSION OF A BID SHALL BE CONSIDERED FIRM EVIDENCE THAT THE BIDDER HAS MADE SUCH EXAMINATION AND IS SATISFIED AS TO THE CONDITIONS TO BE ENCOUNTERED IN PERFORMING THE WORK AND AS TO THE REQUIREMENTS OF THE PLANS AND SPECIFICATIONS.

- SEE GRADING PLAN FOR ALL ELEVATIONS.
- ASPHALTIC PAVEMENT TO BE 1" MIN. ABOVE LIP OF ALL CONCRETE SWALES (E.G. VALLEY GUTTER, CURB'S GUTTERS, ETC.).
- TYPE 2 GRAVEL BASE IS TO BE CONTINUOUS UNDER ADJACENT STRUCTURES AS SHOWN.
- PROVIDE 1" EXPANSION JOINT MATERIAL AT ALL ADJACENT CONCRETE STRUCTURES AS SHOWN.
- FOR ALL CONCRETE STRUCTURES PROVIDE EXPANSION JOINT AT 30' O.C. AND WEAKENED PLAN JOINT AT 10' O.C.

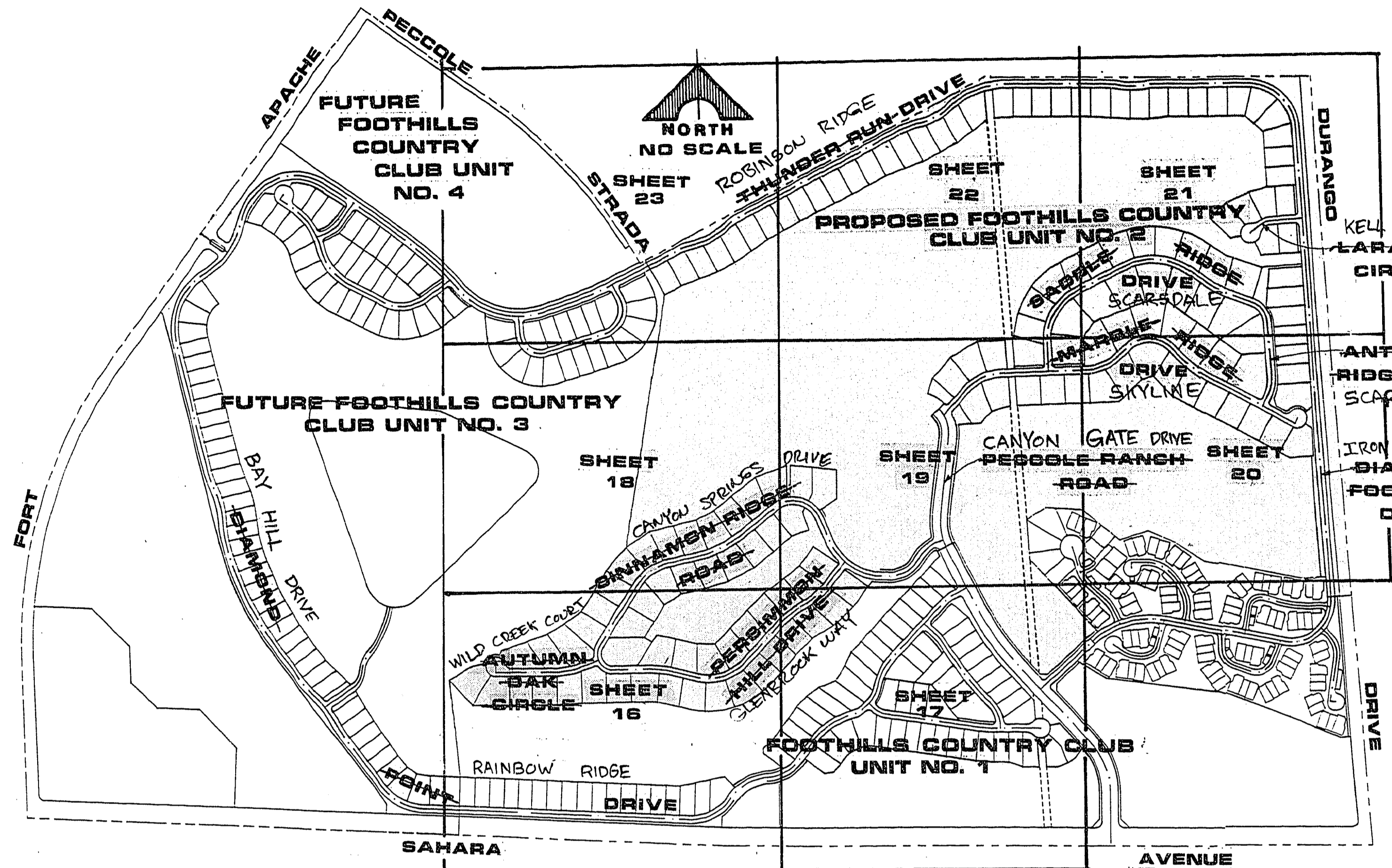

SITE PLAN

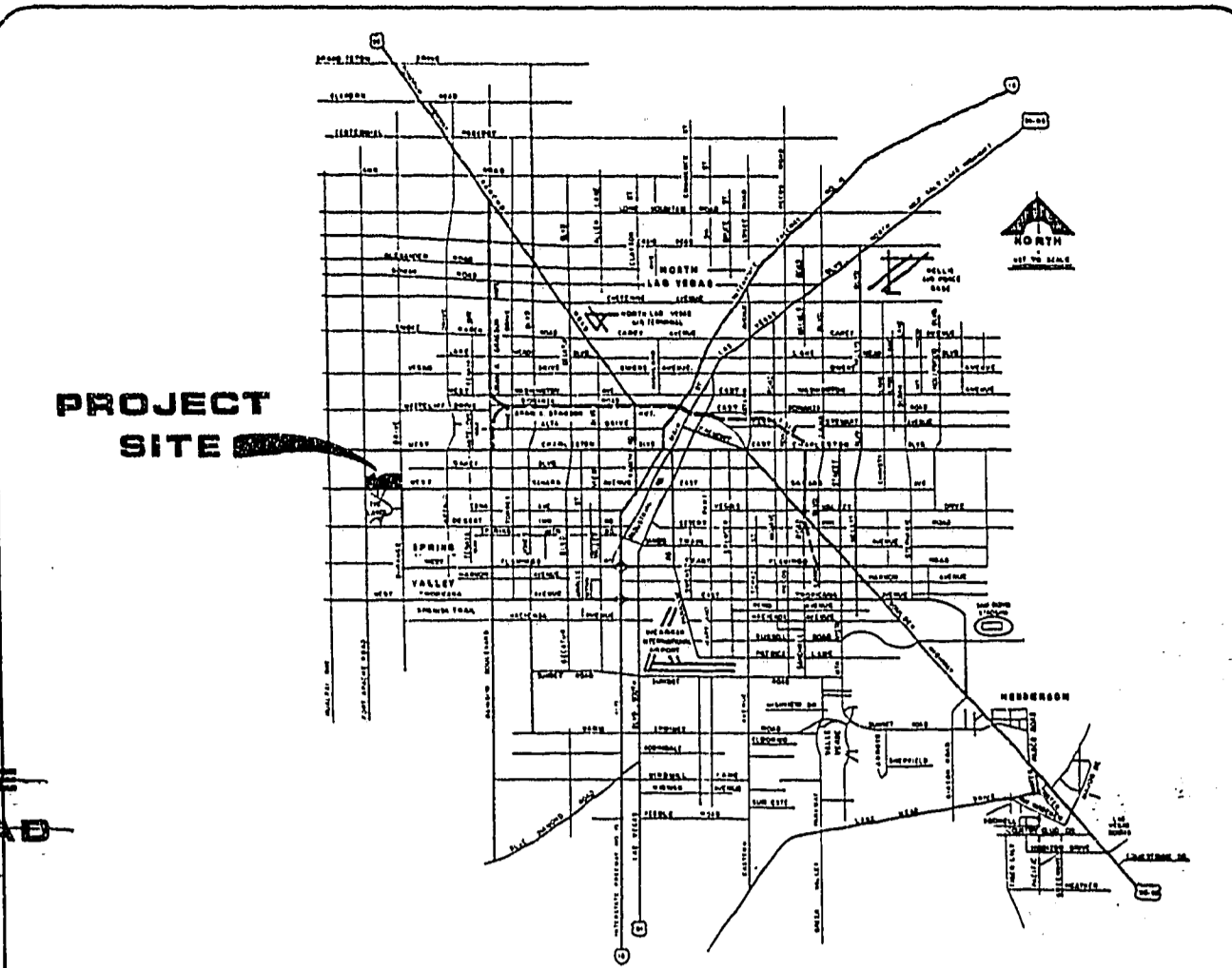

VICINITY MAP

- SLOPE FROM REAR TO SWALE
- SLOPE FROM HOUSE TO SWALE
- SLOPE FROM HOUSE TO SIDE SWALE
- REAR SWALE (3' MIN. FROM REAR OF HOUSE)

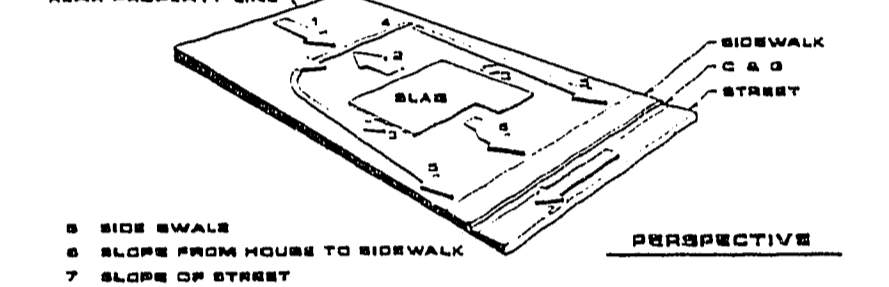

F.H.A. TYPE "A" DRAINAGE

- SLOPE FROM HOUSE TO REAR PROPERTY LINE
- SIDE SWALE
- SLOPE FROM HOUSE TO SIDE SWALE
- SLOPE FROM HOUSE TO SIDEWALK
- SLOPE OF STREET

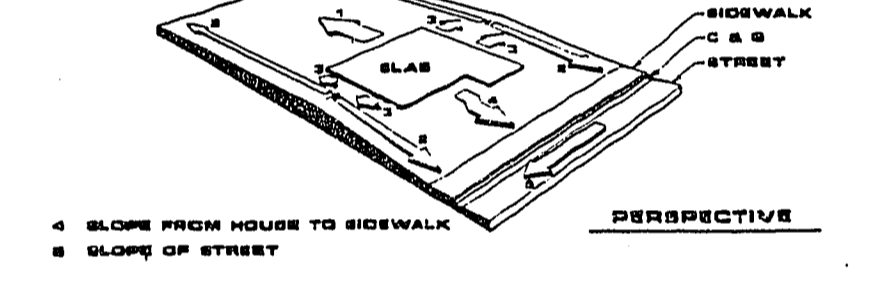

F.H.A. TYPE "B" DRAINAGE

### BENCHMARK

C10504 - NAIL IN WEST SIDE OF POWER POLE NO. 17 AT NORTHWEST QUAD. OF DURANGO DRIVE AND SAHARA AVENUE. CLARK COUNTY DATUM ELEV. = 2661.99.

### LEGEND

- LOT NUMBER
- BLOCK NUMBER
- PAD ELEVATION
- FINISHED GRADE
- EXISTING ELEVATION
- FUTURE ELEVATION
- ROUGH GRADE ELEVATION
- GRADE BREAK
- SCARP
- DITCH OR SWALE
- EXISTING CONTOUR
- FINISHED FLOOR

Call before you Dig.  
1-800-227-2600  
UNDERGROUND SERVICE (USA)

### APPROVAL:

*[Signature]*  
CLV CHIEF LAND DEVELOPMENT  
8-10-97  
DATE

REV	DATE	DESCRIPTION
1	7/6/97	DATE
2	7/6/97	DATE

RECORDED & RETURNED TO THE OFFICE OF THE CLERK OF DISTRICT COURT, CLARK COUNTY, NEVADA, 100 WEST WASHINGTON AVENUE, LAS VEGAS, NEVADA 89102

G.C. WALLACE, INC.  
Engineering/Architecture

FOOTHILLS COUNTRY CLUB UNIT NO. 2  
AT PECCOLE RANCH

GRADING NOTES & MISCELLANEOUS

SHEET  
15  
OF 36 SHEETS

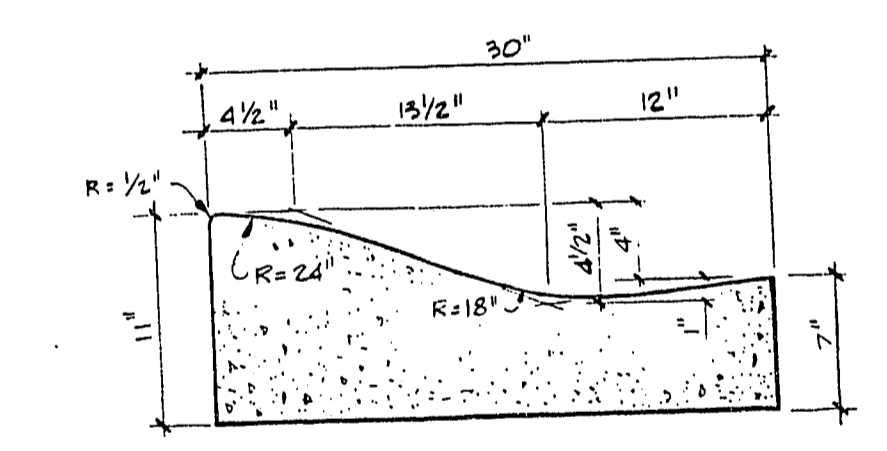

TYPICAL SECTION ROLL TYPE CURB AND GUTTER

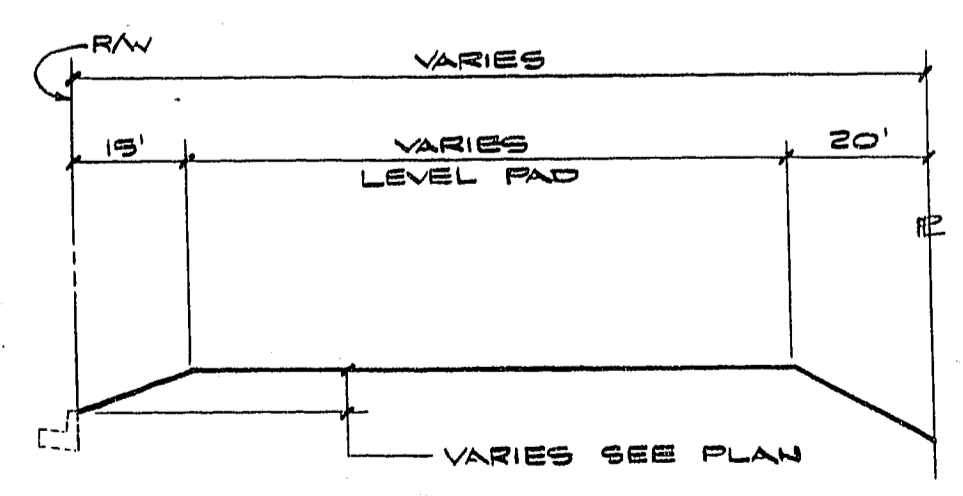

SECTION

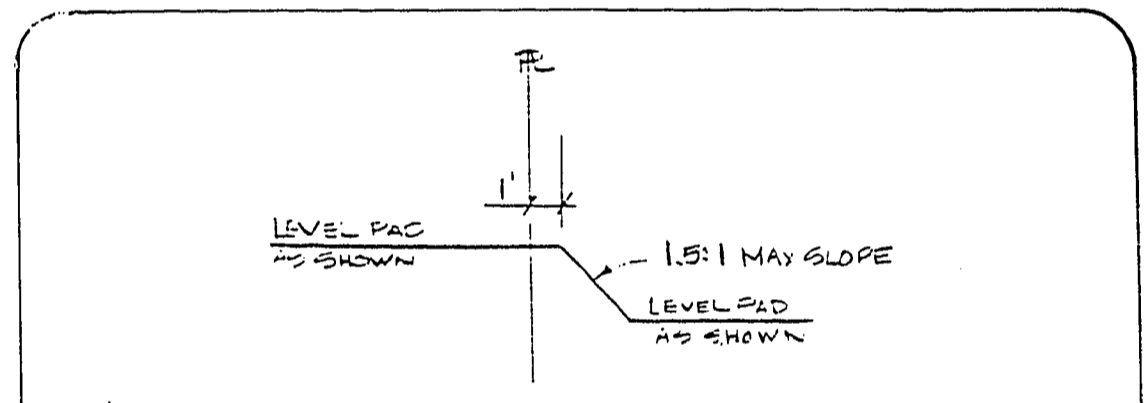

SECTION

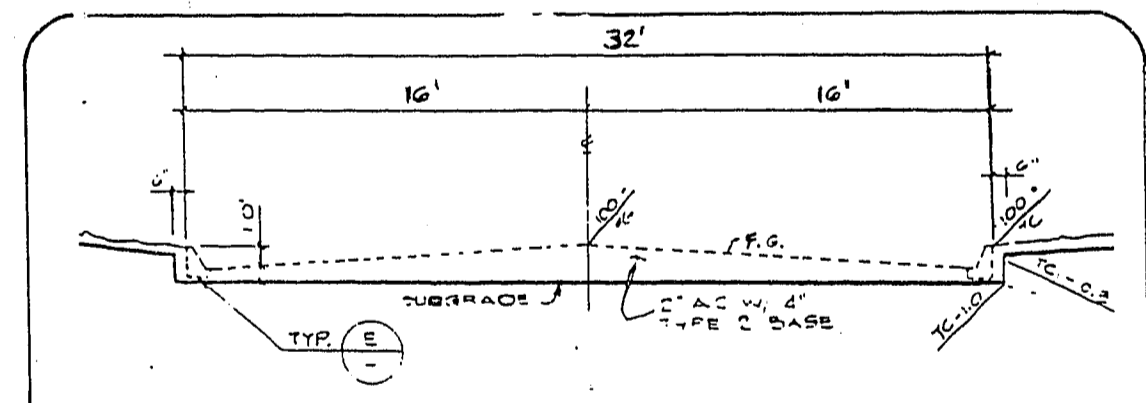

SECTION

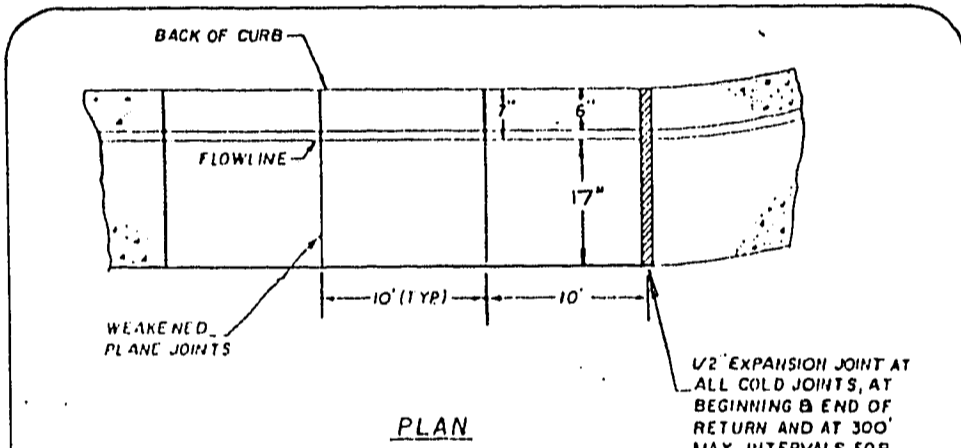

PLAN

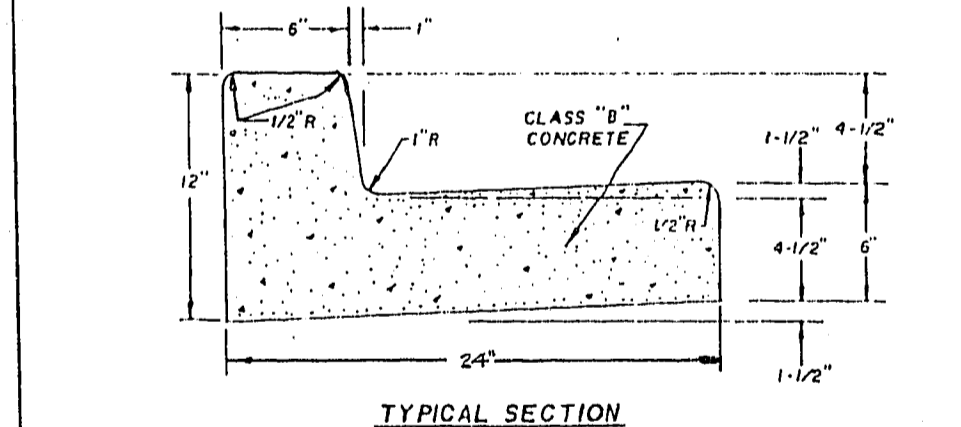

TYPICAL SECTION

"L" TYPE CURB & GUTTER

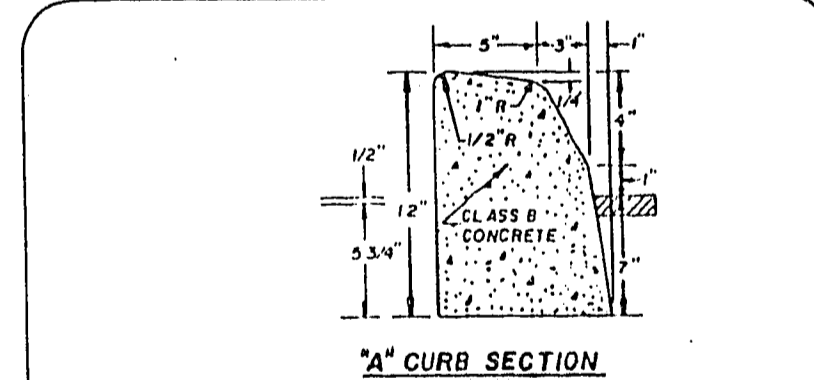

"A" CURB SECTION

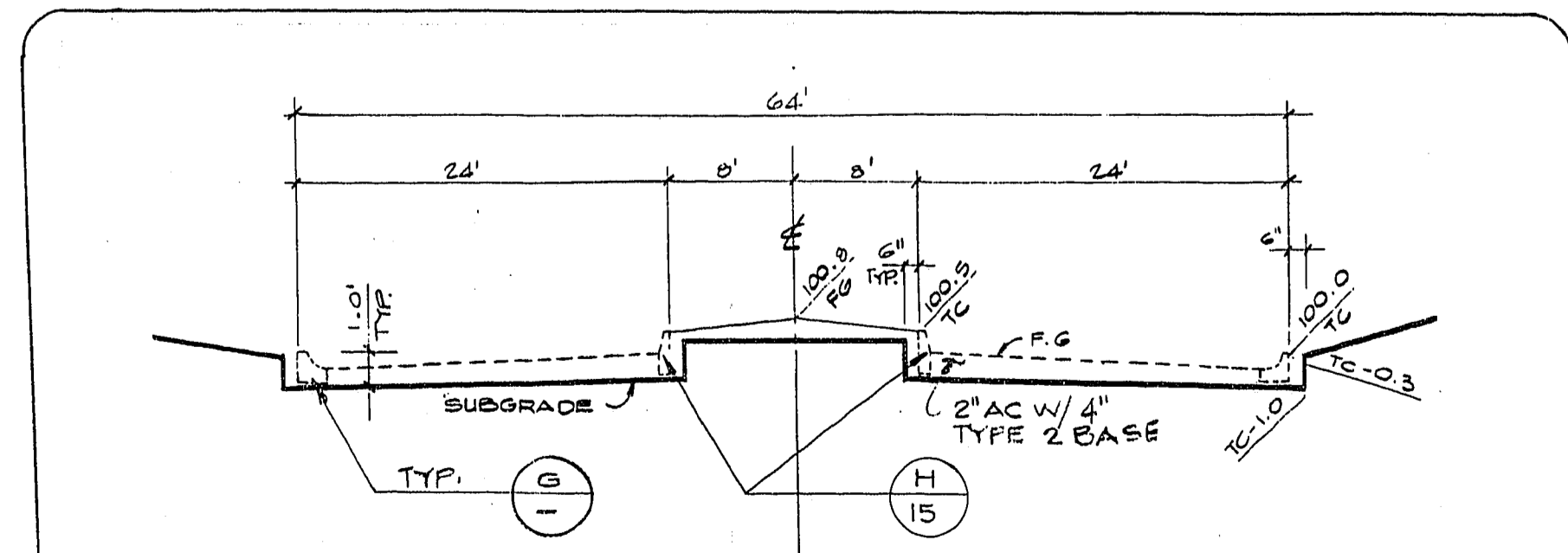

SECTION

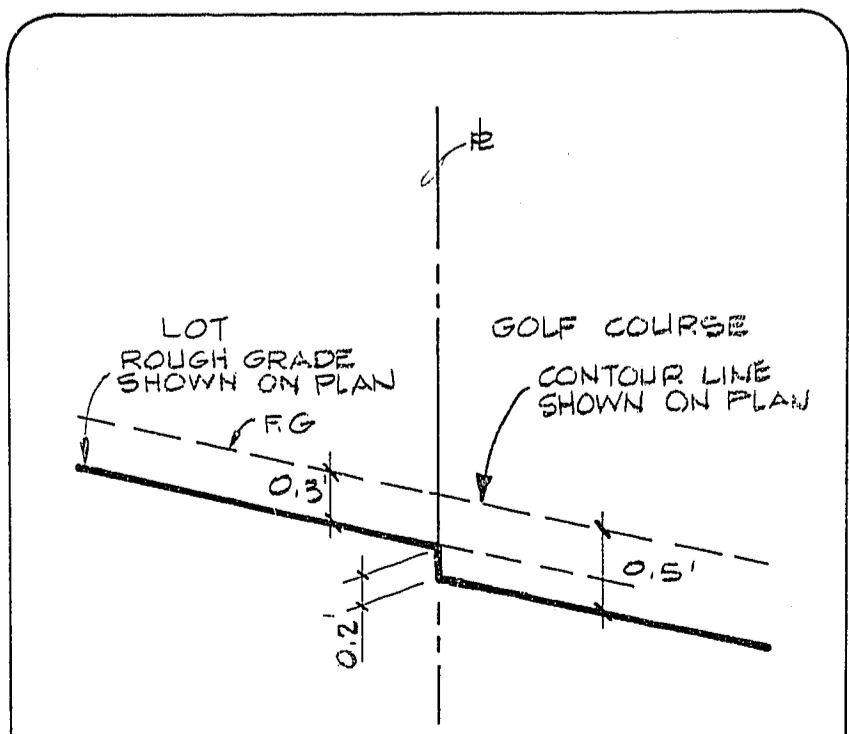

SECTION