

- CONSTRUCTION NOTES**
- ⑫ INSTALL CHAIN LINK FENCE AND MOW STRIP PER DETAIL R SHEET 17 (C7.03)
 - ⑭ INSTALL GATES
 - ⑮ CONSTRUCT RETAINING WALL PER DETAILS SHEET 20 (C9.02)
 - ⑰ INSTALL 18" RCP
 - ⑱ INSTALL TYPE 1 MANHOLE PER STD DWG 403 W/NEENAH R-2520 FRAME & GRATE

TENNIS COURT AREA

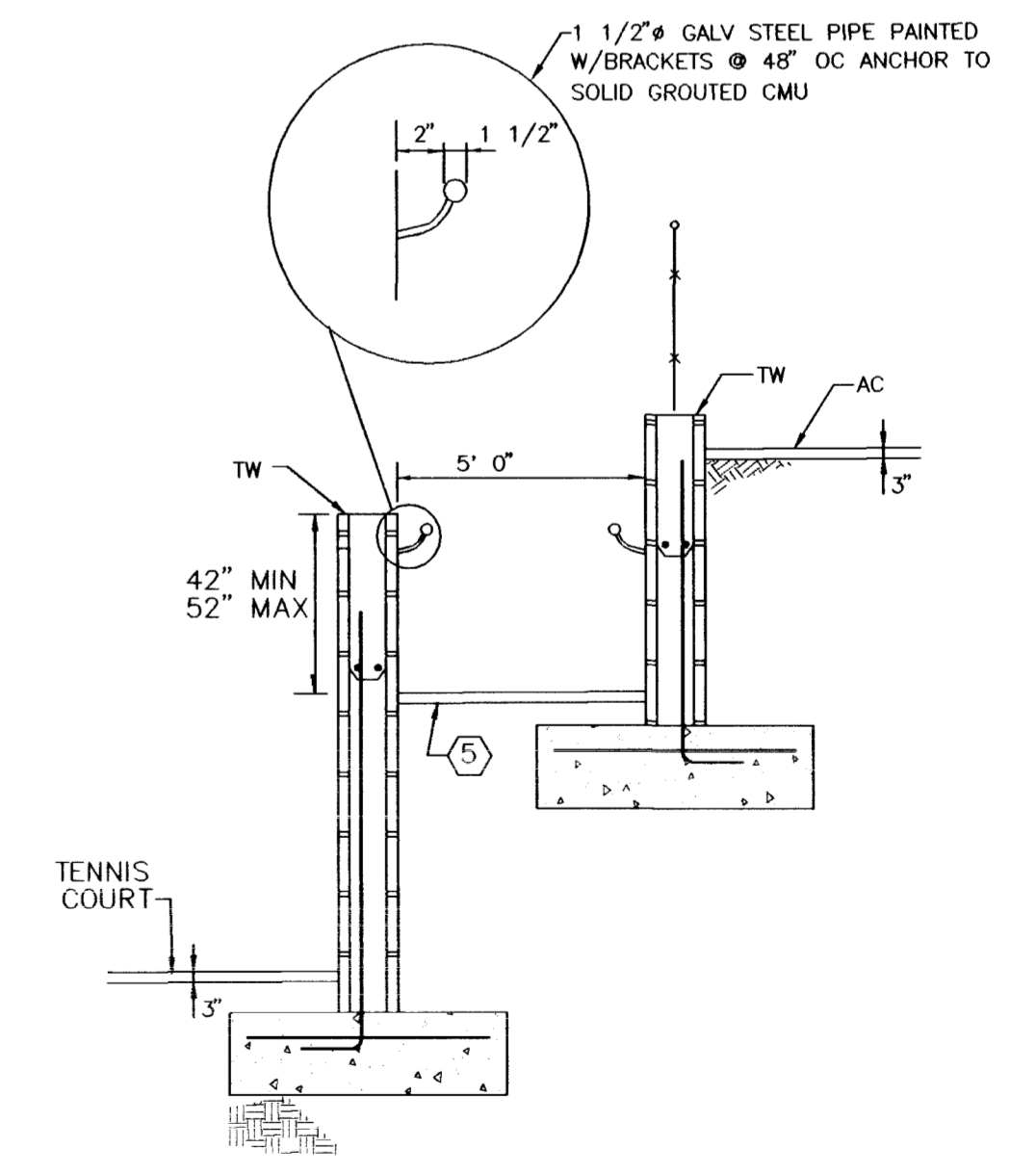
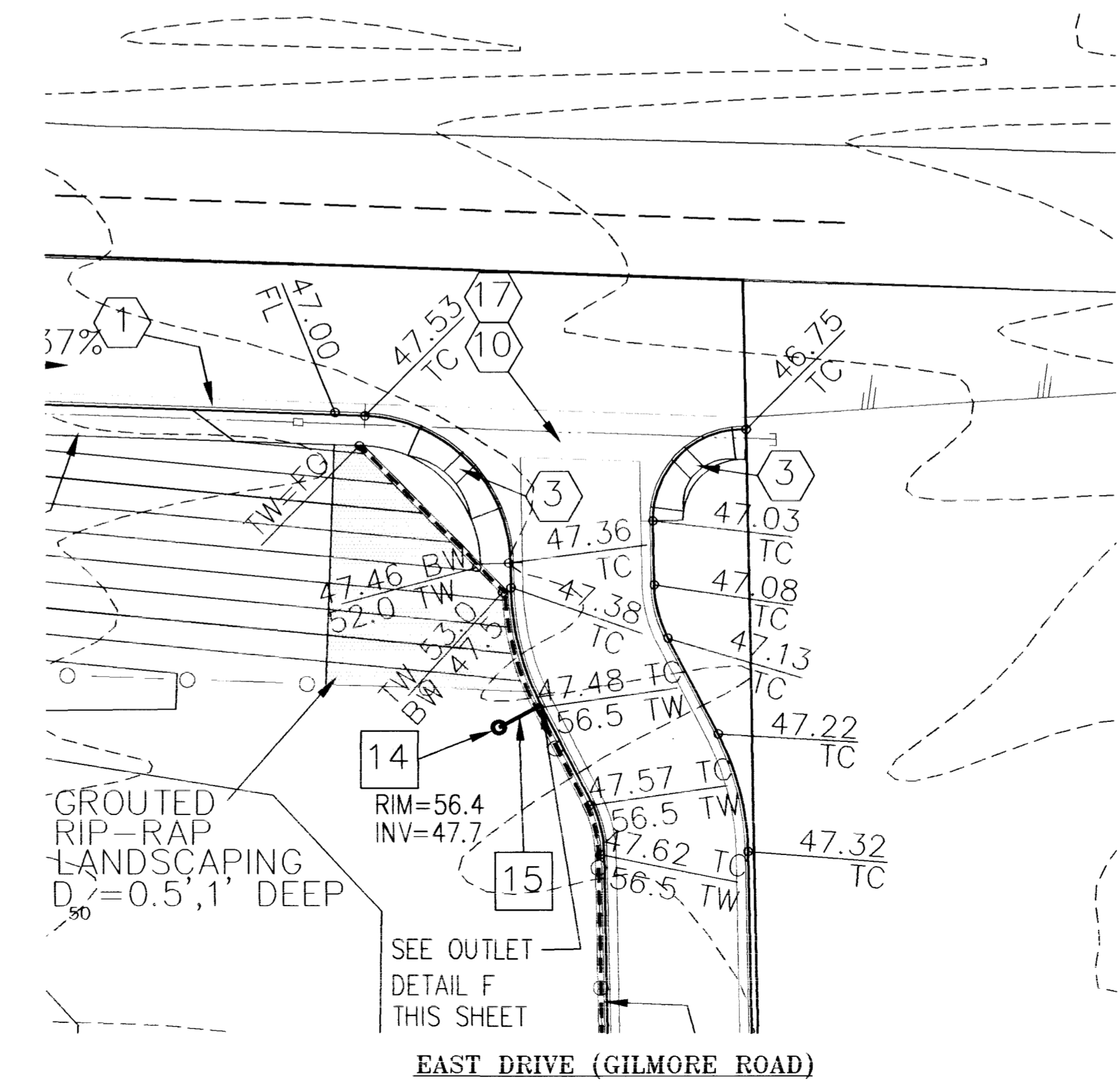
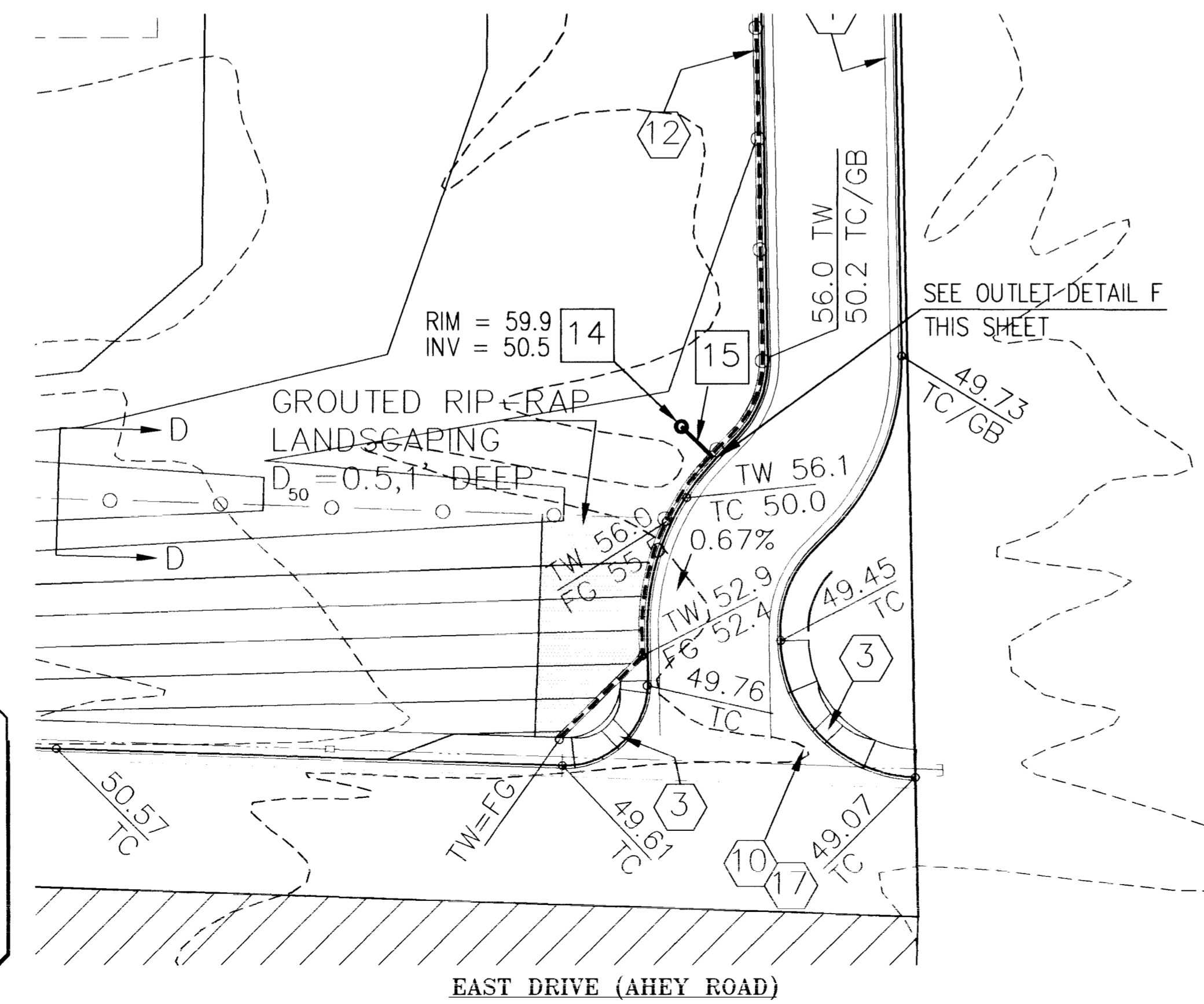

SECTION A
NTS

UTILITY NOTE

UTILITY LOCATIONS SHOWN HEREON ARE APPROXIMATE ONLY. IT SHALL BE THE CONTRACTOR'S RESPONSIBILITY TO DETERMINE THE EXACT HORIZONTAL AND VERTICAL LOCATION OF ALL EXISTING UNDERGROUND UTILITIES PRIOR TO COMMENCING CONSTRUCTION. NO REPRESENTATION IS MADE THAT ALL EXISTING UTILITIES ARE SHOWN HEREON. THE ENGINEER ASSUMES NO RESPONSIBILITY FOR UTILITIES NOT SHOWN OR UTILITIES NOT SHOWN IN THEIR PROPER LOCATION.

Avoid cutting underground utility lines. It's costly.
Call before you Dig
1-800-227-2600
UNDERGROUND SERVICE (USA)

SUMMIT™ ENGINEERING CORPORATION
CONSULTING ENGINEERS AND SURVEYORS
3441 SOUTH HIGHLAND, LAS VEGAS, NEVADA 89103
PHONE: 702-252-3238 FAX: 702-252-3247

DESIGNED BY: W.T.M
DRAWN BY: W.T.M.
CHECKED BY: R.D.C.
SEPT. 26, 1997

IRWIN MOLASKY MIDDLE SCHOOL
CCSD #0663
RETAINING WALLS

NEVADA
CLARK COUNTY
LAS VEGAS

REV.	DATE	DESCRIPTION	BY	APP'D

SCALE: HORIZ. 1" = 20', VERT. N/A

SHEET 19 OF 20

JOB NO. 71362
K:J71362.DET-RET.WKS

1-71-98

MARGARET C. BRAKE
REGISTERED PROFESSIONAL ENGINEER
STATE OF NEVADA
No. 10133

3064

715-100

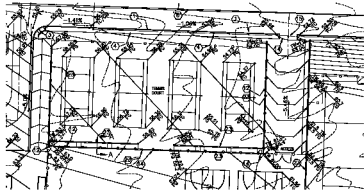

MAIN CAMP AREA



CONSTRUCTION NOTES

- ① POINT FROM WHICH ALL DIMENSIONS ARE TAKEN
- ② WEST TO EAST
- ③ SOUTH TO NORTH
- ④ DIMENSIONS MEASURED TO THE CENTER POINT OF ROAD
- ⑤ POINT OF VIEW
- ⑥ POINT FROM WHICH ALL DIMENSIONS ARE TAKEN

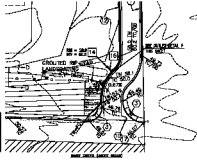

MAIN CAMP UTILITY ROAD

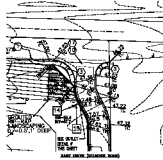

MAIN CAMP UTILITY ROAD

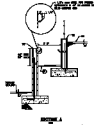

SUMMIT

DATE: _____

SCALE: _____

PROJECT: _____

BY: _____

CHECKED BY: _____

APPROVED BY: _____

DATE: _____