

SEE SHEET 37  
MATCH LINE - STA 56+00

MATCH LINE - STA 56+00  
SEE SHEET 37

56 57 58 59 60 61 62 63 64

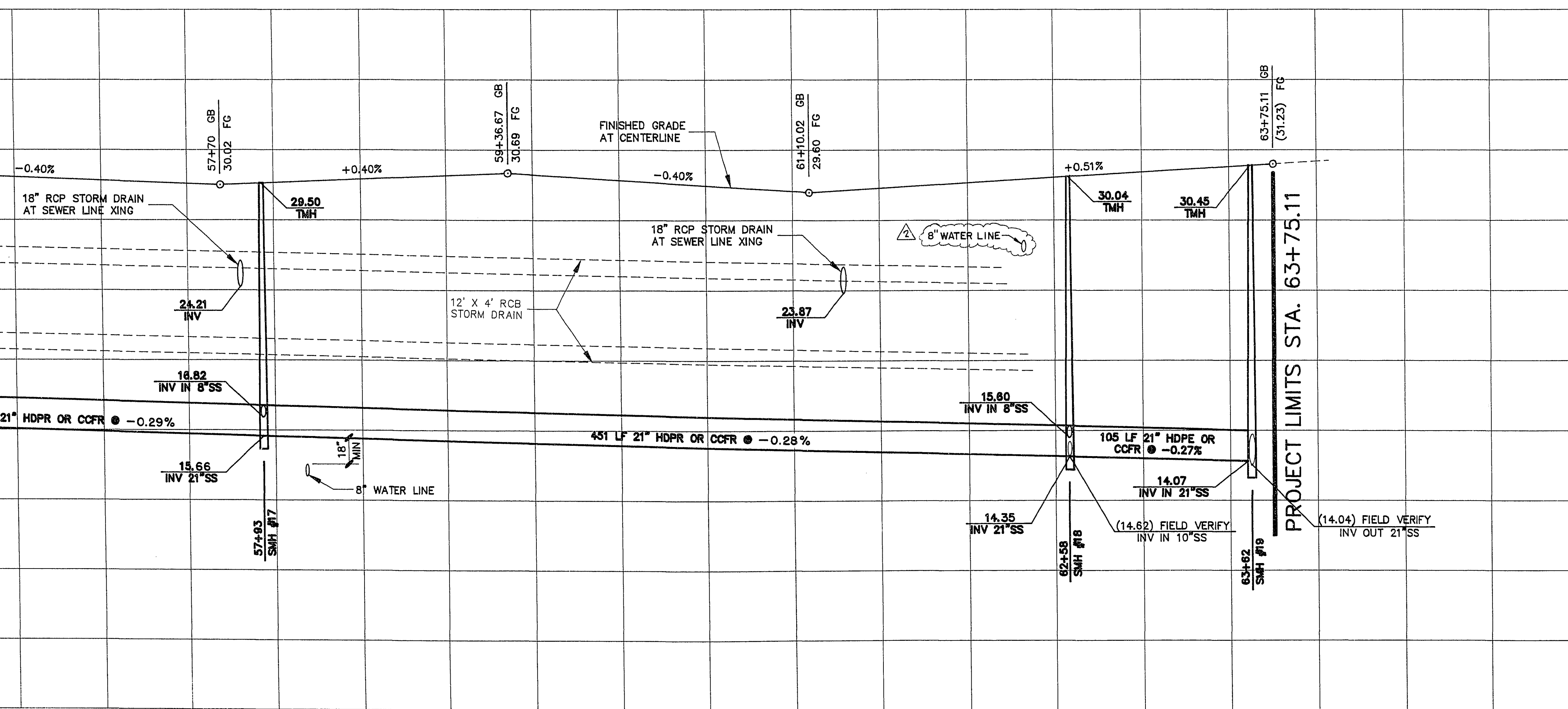
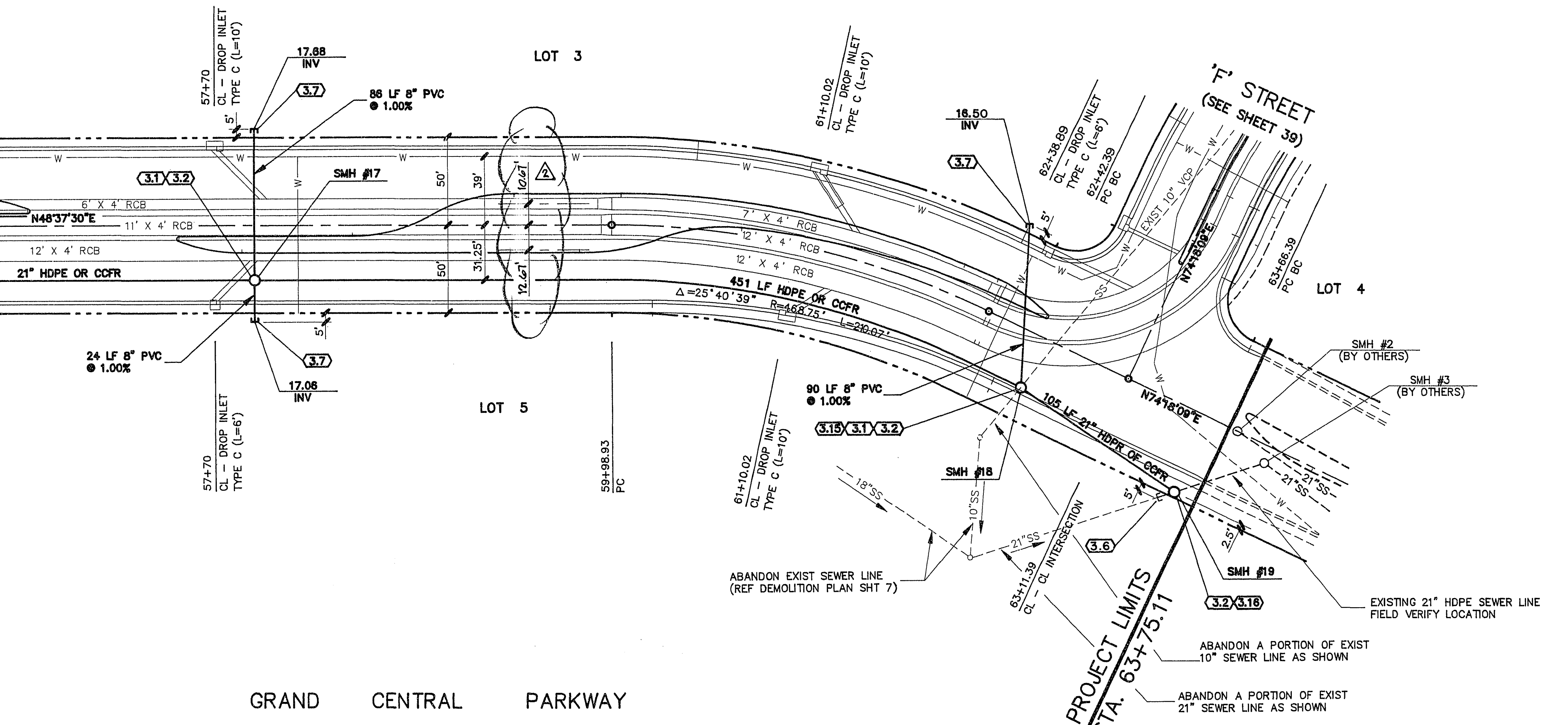
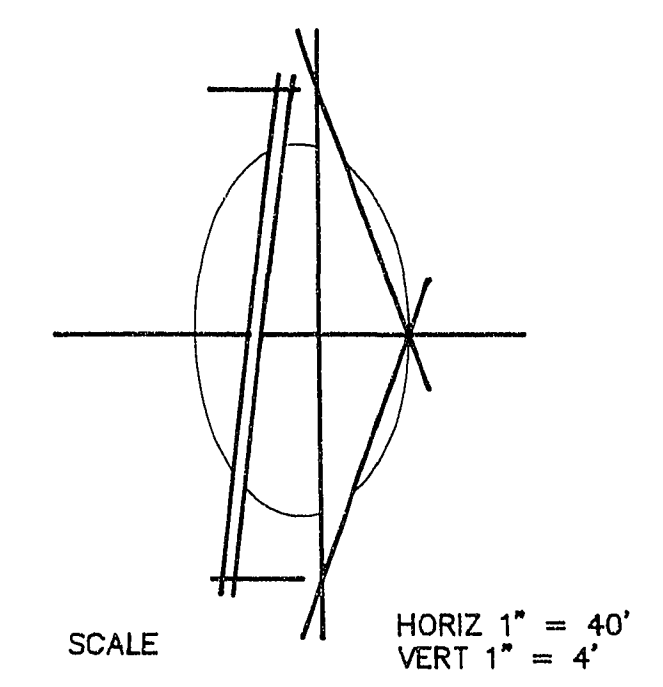

*James W. [Signature]*  
1/20/14

DATE	NO.	REVISIONS	APP'D
12/17/03	1	REVISE SEWER ALIGNMENT, REVISIONS TO BE MADE	[Signature]
5/11/04	2	REVISE VERT. ALIGNMENT P/W/AL STA. 62+32	[Signature]
PREPARED FOR: <b>UNION PACIFIC REALTY CO.</b>			
DATE	DEC.	1993	
DESIGN	AWM		
DRAWN	AWM		
CHECK	AWM		
SCALE	H 1"=40' V 1"=4'		
<b>BAUGHMAN &amp; TURNER, INC.</b> CIVIL ENGINEERS LAND PLANNERS LAND SURVEYORS LAS VEGAS, NEVADA 1210 HINSON STREET (702) 870-8771			
<b>SEWER DESIGN</b> <b>GRAND CENTRAL PARKWAY</b> SECTION 33624, TOWNSHIP 20 SOUTH, RANGE 61 EAST, M.D.B. #4 CITY OF LAS VEGAS, NEVADA <b>PARKWAY CENTER</b>			
SHEET 			
PROJ. NO. UPR/SS38			