

3 TRACK CROSSING
N.T.S.

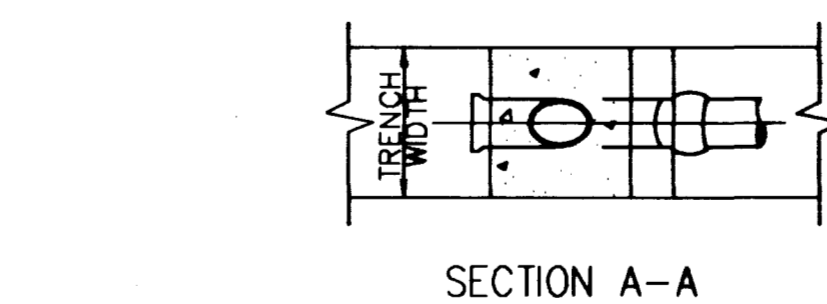
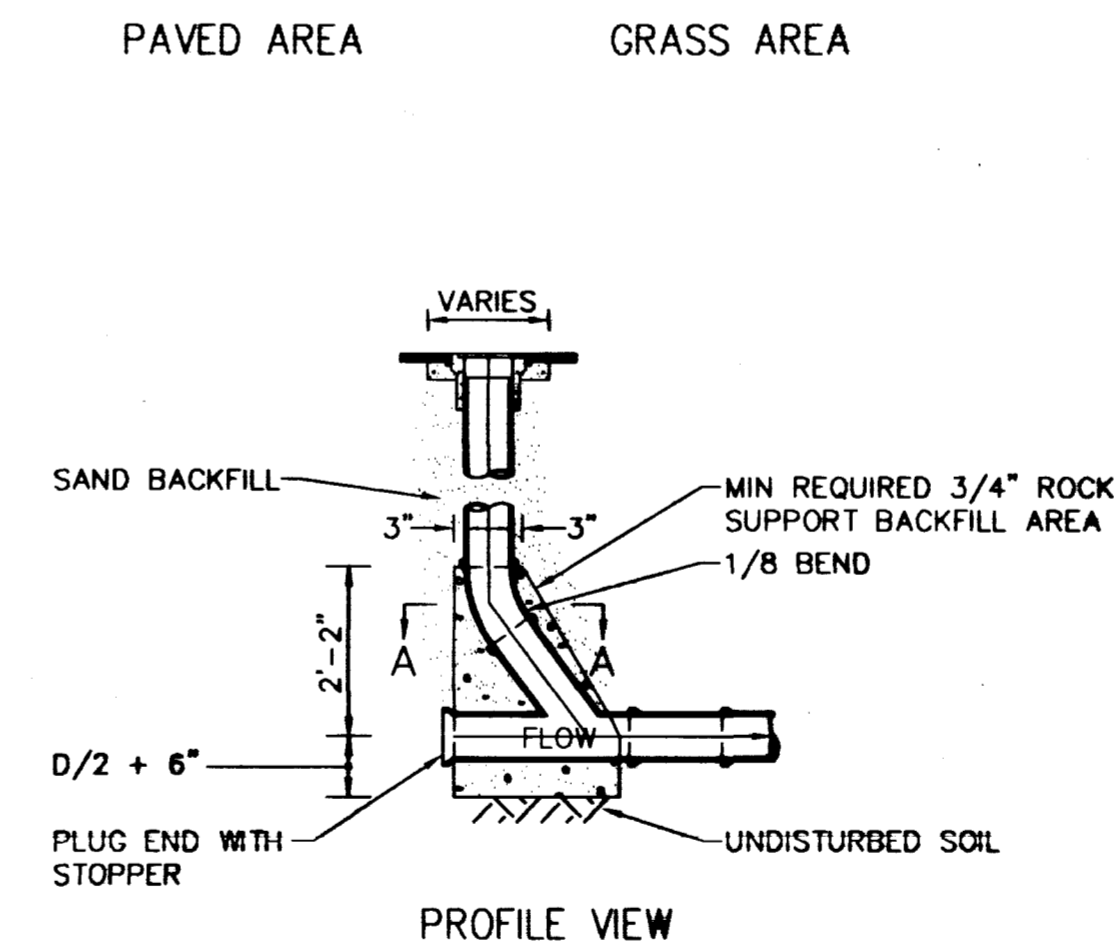
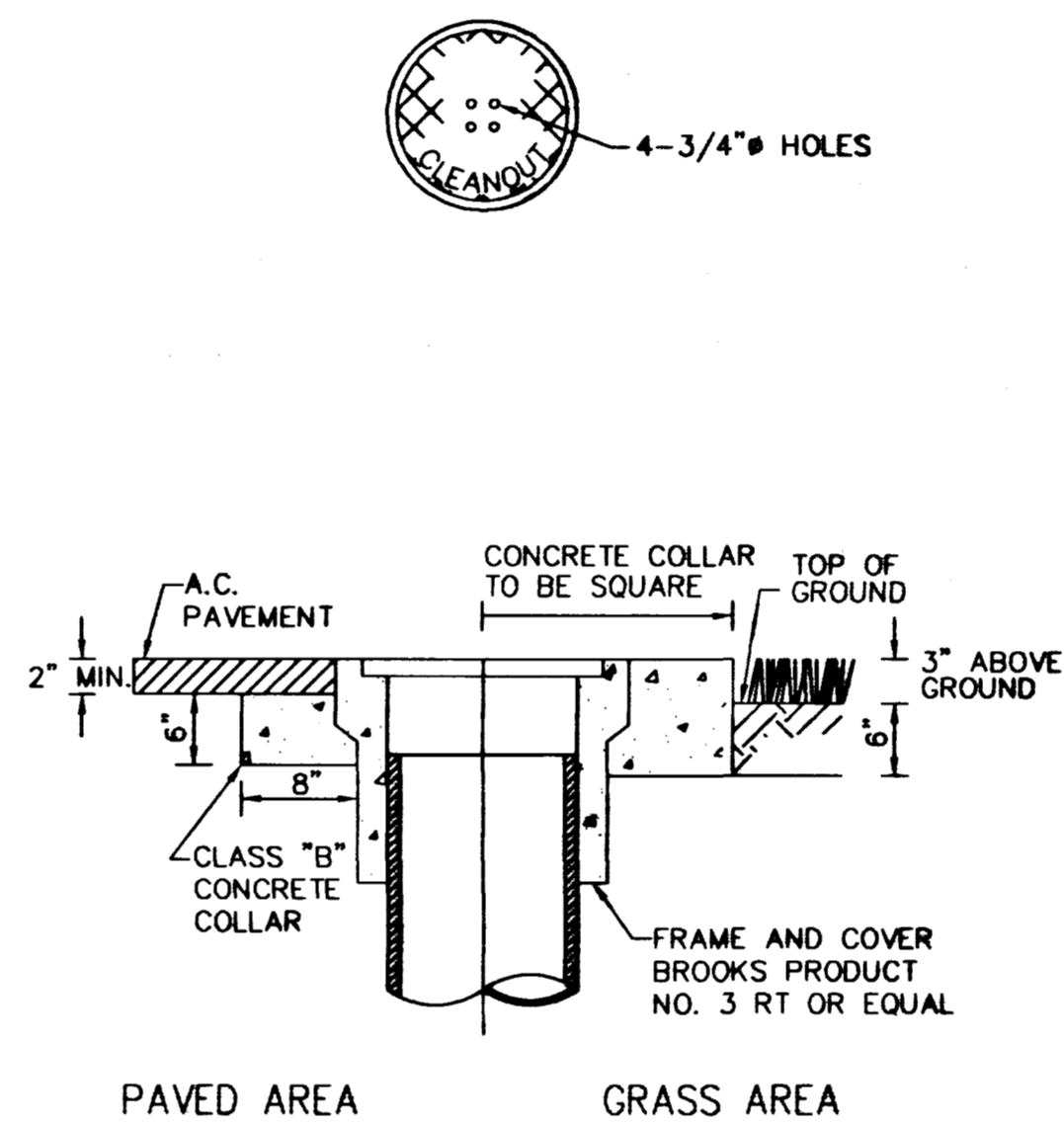

NOTE:
CLEANOUT PIPE TO BE SAME SIZE AND KIND OF MATERIAL AS MAIN.

2 CLEANOUT
N.T.S.

- SPECIFICATIONS:**
- 1) CONCRETE: $f'_c = 2500$ p.s.i., TYPE V
 - 2) STEEL: ASTM A615, Gr40
 - 3) POUR FOOTING AGAINST UNDISTURBED SOIL

D	H	L	STEEL (lbs.)	CONC. (c.y.)
12"	2'-8"	5'-0"	35	0.60
15"	2'-11"	6'-0"	40	0.75
18"	3'-2"	7'-0"	50	0.91
21"	3'-5"	7'-6"	60	1.02
24"	3'-8"	8'-6"	75	1.20
30"	4'-6"	10'-6"	100	1.50

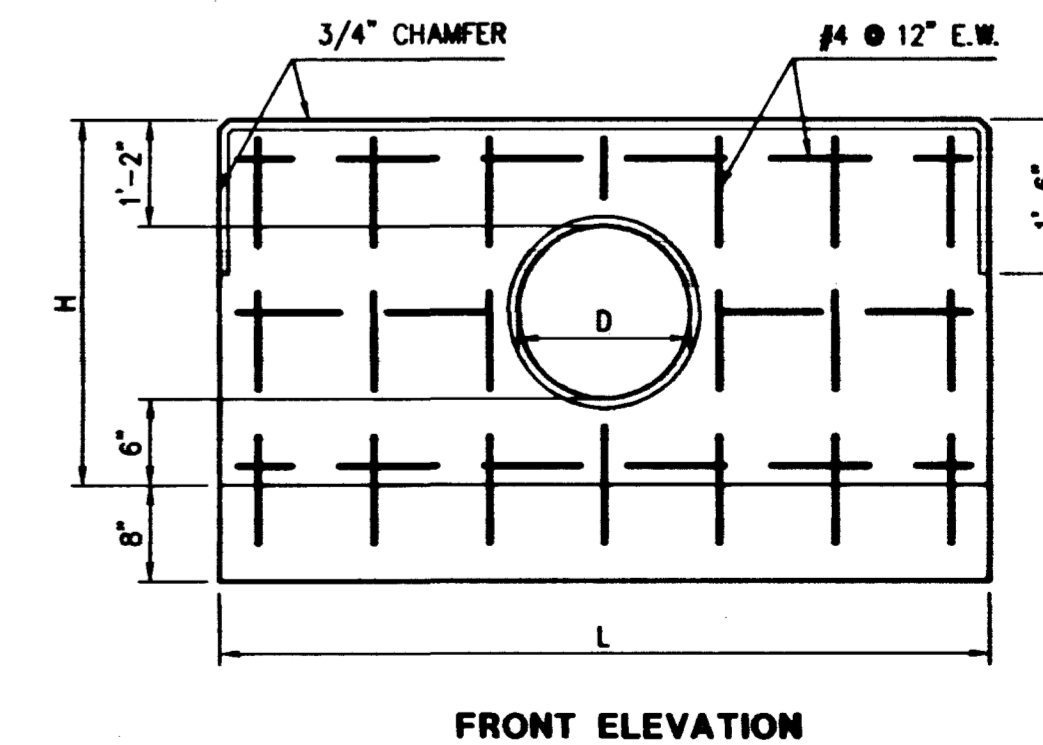
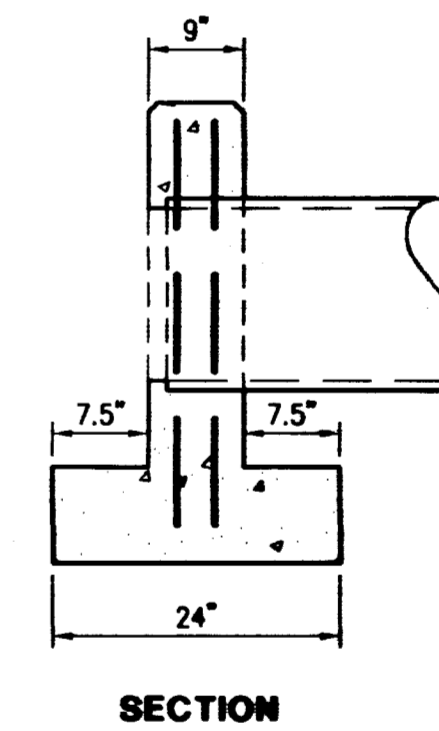

1 HEADWALL
N.T.S.

LAS VEGAS REVIEW-JOURNAL

1111 W. BONANZA ROAD
LAS VEGAS, NEVADA 89125-0070
702-383-0466

**GRADING PLAN
DETAIL SHEET 2**

**LAS VEGAS REVIEW-JOURNAL
PRESS ADDITION**

SHEET
SCALE: N/A

DRAWN BY: J.S.B./J.S.
DESIGNED BY: J.S.B./J.S.
CHECKED BY: J.S.B./J.S.
PROJECT NO: 22.09
SCALE: N/A

SEAL
PROFESSIONAL ENGINEER-STATE OF NEVADA
JOEL S. CRAWFORD
CIVIL
No. 12274
3/18/99

SHEET
9-6
11 OF 11 SHEETS
DRAWING NO
107V2843

1100 S. COAST HWY., #211
LAGUNA BEACH, CA 92651
PH: 714-376-6407
FAX: 714-376-6417
REVISION

1982

