

**BENCHMARK**  
 NORTH AMERICAN VERTICAL DATUM OF 1988  
 1 1/2" X 1/2" RIVET & PLATE IN TOP OF CURB, SE CURB RETURN OF SAHARA AVENUE AND HUALAPAI WAY. ELEVATION = 886.383 METERS (2908.092')

**LEGEND**

- UNIT LINE
- - - EXISTING GRADE CONTOUR
- ( ) EXISTING ELEVATION
- 1.00% RATE & DIRECTION OF FLOW
- - - LOT DRAINAGE SWALE
- ▲ SCARP (2' HOR. TO 1' VERT.) UNLESS OTHERWISE NOTED
- ○ ○ ROUGH PAD ELEVATION
- GB GRADE BREAK
- TC TOP OF CURB ELEVATION
- FL FLOWLINE ELEVATION
- FG FINISH GRADE ELEVATION
- △ HEIGHT OF RETAINING WALL
- - - EX. 24" S.D. EXISTING STORM DRAIN
- - - 24" S.D. PROPOSED STORM DRAIN
- EXISTING DROP INLET
- PROPOSED DROP INLET
- CENTER LINE
- - - OFFSET CROWN
- ○ ○ LOT NUMBER
- ○ ○ BLOCK LETTER
- - - RETAINING WALL
- BLOCK WALL

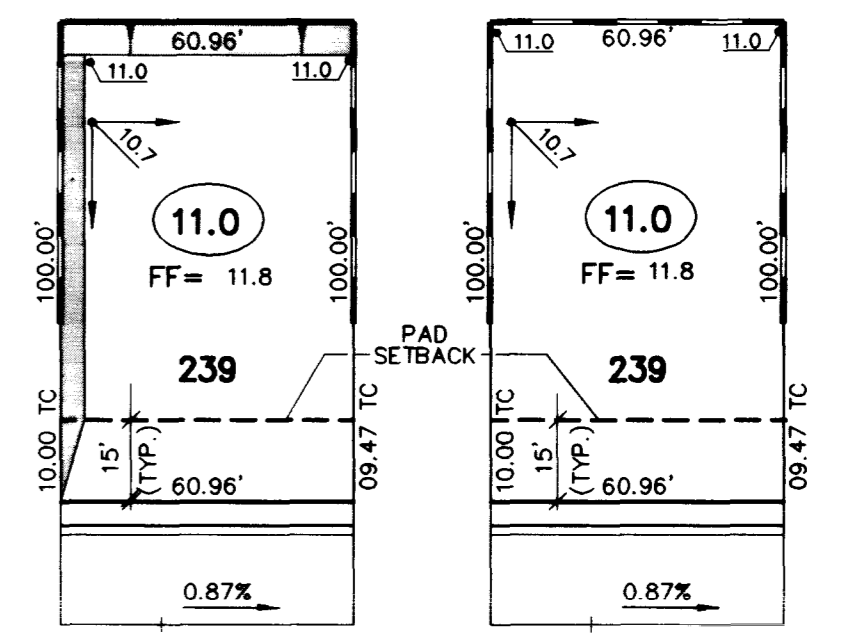

**TYPICAL LOT GRADING ELEVATION RELATIONS AND BLOCK WALL LOCATIONS**

BLOCK WALLS WILL BE PROVIDED AT ALL REAR AND SIDE LOT LINES EXACT LOCATION AND DIM. OF SIDE YARD WALLS WILL BE DETERMINED AT TIME OF PLOT PLAN SUBMITTALS.

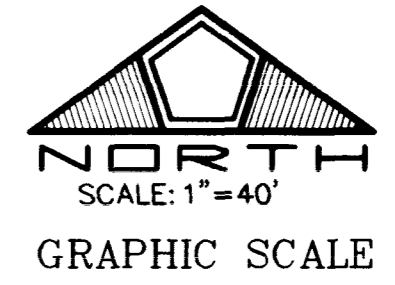

**APPROVAL NOTE**  
 I CERTIFY THIS GRADING PLAN IS IN CONFORMANCE WITH THE CITY OF LAS VEGAS. DATE: 9/18/96

DATE: 9/18/96  
 DESIGNED BY: [Signature]  
 CHECKED BY: [Signature]  
 JOB NO.: 0164.0003  
 SCALE: 1" = 40'

**PENTACORE**  
 CIVIL ENGINEERING - LAND SURVEYING - PLANNING  
 CONSTRUCTION MANAGEMENT - ADA CONSULTING  
 6763 WEST CHARLESTON BOULEVARD  
 LAS VEGAS, NEVADA 89102 (702)258-0115

SIGNATURE HOMES  
 PECOCLE VILLAGE - UNIT 2  
 UNIT 2  
 GRADING PLAN

5851

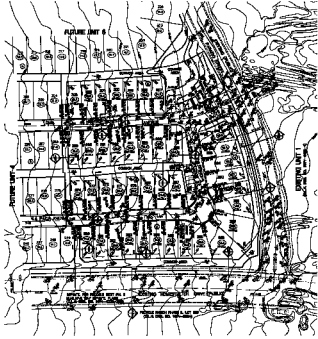

**NOTE**  
 THIS MAP IS NOT TO BE USED FOR  
 SECURITY PURPOSES

**LEGEND**

- 100 FT. ELEVATION
- 200 FT. ELEVATION
- 300 FT. ELEVATION
- 400 FT. ELEVATION
- 500 FT. ELEVATION
- 600 FT. ELEVATION
- 700 FT. ELEVATION
- 800 FT. ELEVATION
- 900 FT. ELEVATION
- 1000 FT. ELEVATION
- 1100 FT. ELEVATION
- 1200 FT. ELEVATION
- 1300 FT. ELEVATION
- 1400 FT. ELEVATION
- 1500 FT. ELEVATION
- 1600 FT. ELEVATION
- 1700 FT. ELEVATION
- 1800 FT. ELEVATION
- 1900 FT. ELEVATION
- 2000 FT. ELEVATION
- 2100 FT. ELEVATION
- 2200 FT. ELEVATION
- 2300 FT. ELEVATION
- 2400 FT. ELEVATION
- 2500 FT. ELEVATION
- 2600 FT. ELEVATION
- 2700 FT. ELEVATION
- 2800 FT. ELEVATION
- 2900 FT. ELEVATION
- 3000 FT. ELEVATION
- 3100 FT. ELEVATION
- 3200 FT. ELEVATION
- 3300 FT. ELEVATION
- 3400 FT. ELEVATION
- 3500 FT. ELEVATION
- 3600 FT. ELEVATION
- 3700 FT. ELEVATION
- 3800 FT. ELEVATION
- 3900 FT. ELEVATION
- 4000 FT. ELEVATION
- 4100 FT. ELEVATION
- 4200 FT. ELEVATION
- 4300 FT. ELEVATION
- 4400 FT. ELEVATION
- 4500 FT. ELEVATION
- 4600 FT. ELEVATION
- 4700 FT. ELEVATION
- 4800 FT. ELEVATION
- 4900 FT. ELEVATION
- 5000 FT. ELEVATION



THIS MAP IS NOT TO BE USED FOR  
 SECURITY PURPOSES



SCALE: 1:50000

PENTACORE UNIT

DIXIE UNIT

KEY MAP

GRAPHIC SCALE

1:50000

7