

THIS DRAWING MAY SHOW APPROXIMATE LOCATIONS OF KNOWN UTILITIES IN THE IMMEDIATE VICINITY OF THE WORK TO BE DONE, BUT CENTURYLINK DOES NOT GUARANTEE OR ASSUME LIABILITY FOR THEIR POSITION OR DEPTH. CONTRACTORS SHALL DETERMINE TO THEIR SATISFACTION THE ACTUAL POSITION AND DEPTH OF EXISTING UTILITIES AS THEY WILL ASSUME THIS LIABILITY DURING THE PERFORMANCE OF THIS WORK.

CONTRACTOR IS RESPONSIBLE FOR ALL REQUIRED SURVEYING & STAKING BY A STATE OF NEVADA REGISTERED LAND SURVEYOR AND FOR THE PROPER INSTALLATION OF THE PROPOSED FACILITIES AS REQ'D.

**RTC SOUTHERN NEVADA NOTES:**

- FOR ASPHALT CUT AND RESTORATION REQUIREMENTS, SEE RTC UNIFORM STANDARD DRAWING SERIES 500.1, 500.2, 500.3, 500.4 AND 500.5
- FOR SIDEWALK REMOVAL AND REPLACEMENT REQUIREMENTS SEE RTC UNIFORM STANDARD DRAWING 234
- FOR TYPICAL U.G. UTILITY LOCATIONS UNDER STREETS AND SIDEWALKS, SEE RTC UNIFORM STANDARD DRAWINGS 501 AND 501.1
- FOR BACKFILL REQUIREMENTS SEE RTC STANDARD DRAWING SEE RTC UNIFORM STANDARD DRAWING 503.1
- SEE COMPLETE RTC UNIFORM STANDARD DRAWINGS FOR FURTHER AGENCY REQUIREMENTS

**ESTIMATED QUANTITIES SHOWN IN (PARENTHESIS) AFTER EACH UNIT**

- ① 2-2" PVC, DB-60 GRADE (EST. 285.0')
- ② 1-4" PVC, DB-100 GRADE (EST. 170)
- ③ 2" RGS 36" 90° BENDS DOUBLE WRAPPED 10 MIL PVC TAPE. (4 EA.)
- ④ 4" RGS 48" 90° BENDS DOUBLE WRAPPED 10 MIL PVC TAPE. (1 EA.)
- ⑤ 200 PULL BOX (2'-6"x4'-0"x4'-0"). (2 EA.)
- ⑥ TELEPHONE TERMINAL BACKBOARD 8'X3'X3/4". SEE LEGEND. (1 EA.)

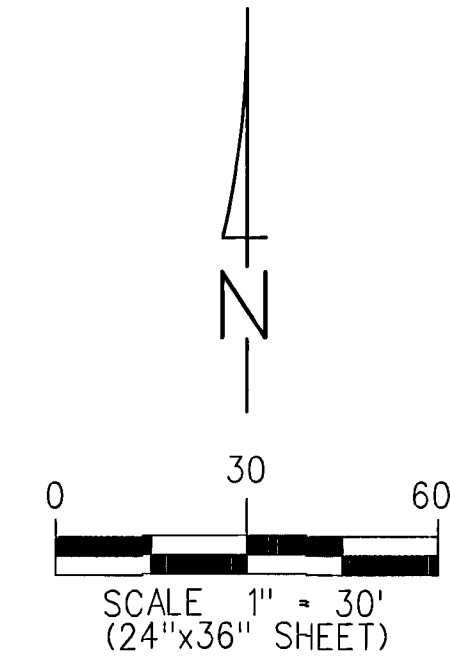

**TRENCH DETAIL - ONSITES  
(2-4" TELEPHONE CONDUIT IN JOINT TRENCH W/ POWER)**

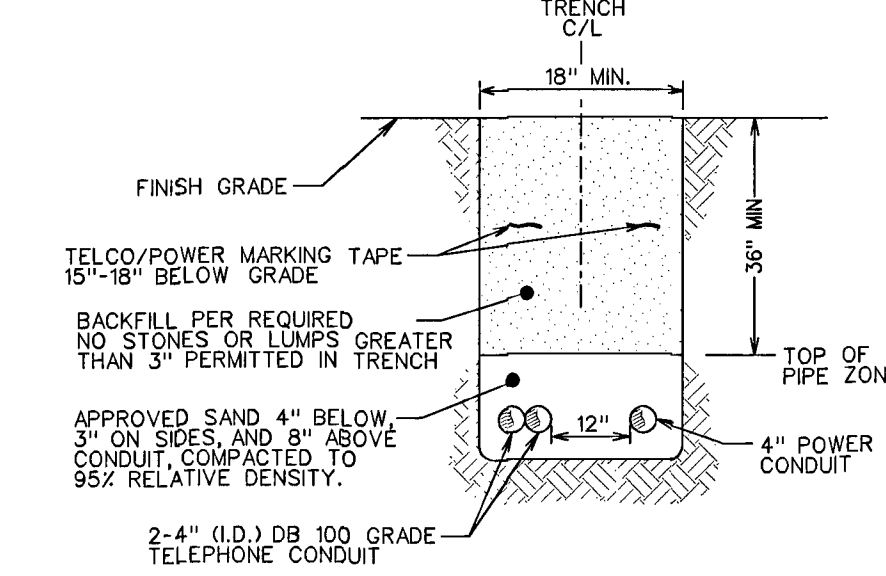

**TRENCH DETAIL - ONSITES  
(2-2" TELEPHONE CONDUIT IN JOINT TRENCH W/ POWER)**

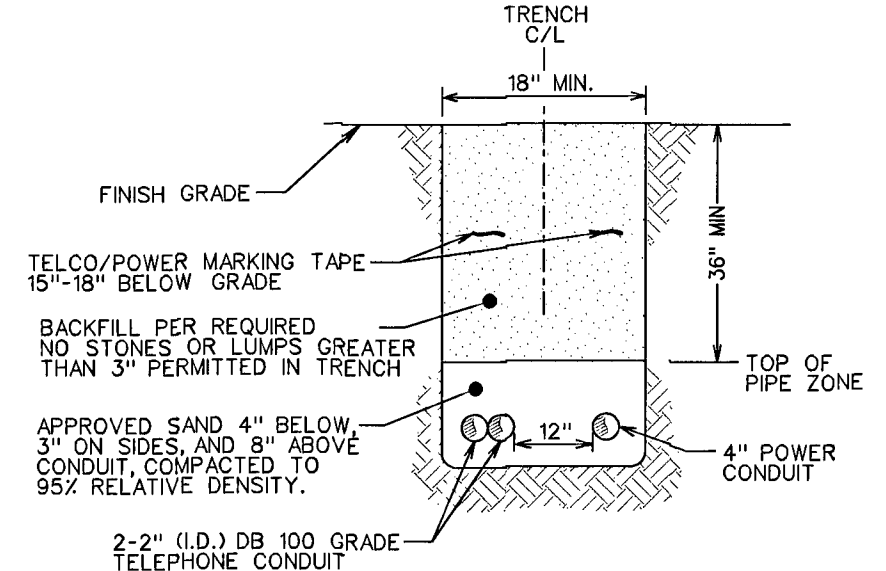

APPROVED FOR CONSTRUCTION  
THIS APPROVAL IS FOR WORK IN CLV  
R/W OR CLV EASEMENTS ONLY.  
OBTAINING PERMISSIONS  
OR EASEMENTS FOR WORK SHOWN ON  
PRIVATE PROPERTY IS THE RESPONSIBILITY  
OF THE UTILITY.

APPROVAL *[Signature]* 10-15-13  
49308 101V5995-UTL DATE

ALL CONSTRUCTION AND MATERIALS SHALL BE IN ACCORDANCE WITH THE "UNIFORM STANDARD SPECIFICATIONS FOR PUBLIC WORKS CONSTRUCTION OFF-SITE IMPROVEMENTS, CLARK COUNTY AREA NEVADA", LATEST ISSUE; THE "UNIFORM STANDARD DRAWINGS FOR PUBLIC WORKS CONSTRUCTION, CLARK COUNTY AREA NEVADA", LATEST ISSUE; AND OTHER APPLICABLE APPROVED STANDARDS ISSUED BY THE CONTROLLING AGENCY; ALL LOCAL CITY CODES AND ORDINANCES APPLICABLE.

SERVICE CANNOT BE PROVIDED WITHOUT APPROVED OPEN TRENCH AND FINAL INSPECTION BY A CENTURYLINK INSPECTOR.

**LEGEND**

- PROPOSED CONDUIT: P.V.C. - D.B. (DIRECT BURIAL) GRADE: D.B. 60 FOR 1", 2", & 3"; D.B. 100 FOR 4"
- EXISTING CONDUIT: RACIAL BENDS: SCHEDULE 40 PVC (TYPICAL) OR RIGID GALVANIZED STEEL (RGS) WITH DOUBLE WRAPPED 10 MIL CORROSION PROTECTION TAPE (AS SHOWN).
- EXISTING PROPOSED: MANHOLE - INCLUDE REQUIRED GRADE RINGS, RACKING, GROUNDING, STEP RUNGS AND LADDER - REFER TO DRAWING FOR SIZE/TYPE.
- 400 PULL BOX (3'0" x 5'0" x 4'0" I.D.) - WITH TWO (2) HINGED ALUMINUM TORSION-ASSISTED TRAFFIC RATED LIDS MARKED 'TELCO', GALVANIZED STEEL ADJUSTING FRAME, AND FOUR (4) 18 HOLE CABLE RACKS (2 EA. SIDE).
- 200 PULL BOX (2'6" x 4'0" x 4'0" I.D.) - WITH TWO (2) H-20-44 LOADING HOT DIP GALVANIZED BOLT DOWN BEAM & PLATE TRAFFIC COVERS MARKED 'TELCO' AND FOUR (4) 18 HOLE CABLE RACKS (2 EACH SIDE).
- 100 PULL BOX (2'0" x 3'0" x 3'0" I.D.) - WITH TWO (2) H-20-44 LOADING HOT DIP GALVANIZED BOLT DOWN BEAM & PLATE TRAFFIC COVERS MARKED 'TELCO' AND FOUR (4) 18 HOLE CABLE RACKS (2 EACH SIDE).
- 30 PULL BOX (17" x 30" x 30" I.D.) - P.C.C. TYPE PULL BOX (ES-30 or T-30C)
- 16 HAND HOLE (9" x 15" x 12" I.D.)
- TERMINAL CABINET 48" x 48" x 6" UNDERWRITER LABORATORY APPROVED, RAIN-TIGHT WITH A NON-LOCKING, SIDE-HINGED DOOR EQUIPPED INSIDE WITH A 3/4" PLYWOOD BACKBOARD (1" SEALER ON FOOT) CENTERED IN CABINET SECURED WITH RECESSED MOUNTING HARDWARE AND A #6 GROUND WIRE CONNECTED TO THE APPROVED COMMUNICATION GROUNDING SOURCE AS DETERMINED BY THE ELECTRICAL ENGINEER FOR THIS BUILDING OR DEVELOPMENT. MOUNT CABINET AT EYE LEVEL A MINIMUM OF 48" ABOVE FINISH GRADE.
- TERMINAL CABINET 36" x 36" x 6"
- TELEPHONE TERMINAL BACKBOARD (T.T.B.) - SEE PLAN FOR SIZE REQUIREMENTS; 3/4" PLYWOOD BACKBOARD TREATED WITH FIRE RETARDANT PAINT OR SEALER AND A #6 GROUND WIRE CONNECTED TO THE APPROVED COMMUNICATION GROUNDING SOURCE AS DETERMINED BY THE ELECTRICAL ENGINEER FOR THIS BUILDING OR DEVELOPMENT. BACKBOARDS SMALLER THAN 4' x 8' (i.e., 2' x 2' & 4' x 4') SHOULD BE MOUNTED 40" ABOVE THE FLOOR.

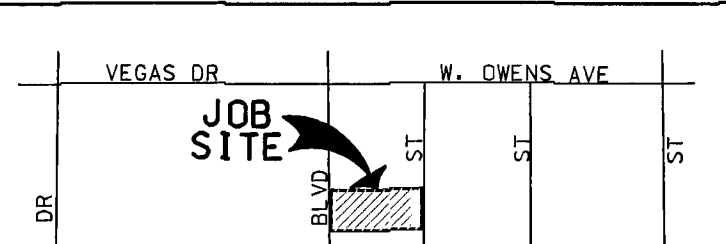

**VICINITY MAP  
T-R-S: 20S-61E-28**

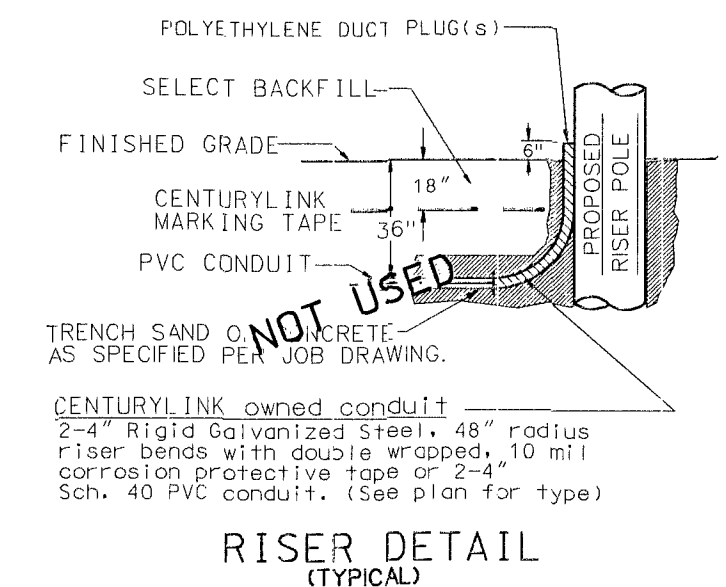

**CONSTRUCTION NOTES**

1. ALL CONSTRUCTION SHALL CONFORM TO THE LATEST ISSUE OF THE CENTURYLINK UNDERGROUND SPECIFICATIONS.
2. ALL CONDUIT, TRENCHING AND SUBSTRUCTURES ARE TO BE PROVIDED BY THE DEVELOPER AND CONFORM WITH CENTURYLINK STANDARDS. ALL BACKFILLING AND RESTORATION WORK SHALL CONFORM TO THE REGIONAL TRANSPORTATION COMMISSION OF SOUTHERN NEVADA (RTC) UNIFORM STANDARD DRAWINGS.
3. WHEN EXISTING TELEPHONE FACILITIES (i.e. POLES, MANHOLES, PULL BOXES, CONDUIT, TERMINALS, etc.) ARE AFFECTED BY IMPROVEMENTS AS REQUIRED BY LOCAL ORDINANCE (I.E. STREETS, SIDEWALKS, GUTTERS, SEWERS, STORM DRAINS etc.), THE DEVELOPER SHALL BE RESPONSIBLE FOR THE ADJUSTMENT OF THESE FACILITIES AS REQUIRED.
4. TELEPHONE BOXES ARE TO BE PLACED BEHIND THE CURB LINE AND/OR IN THE SIDEWALK AREA WHENEVER POSSIBLE AND SITUATED TO AVOID DRIVEWAYS. ALL TRENCHING WILL BE OF A MINIMUM DEPTH TO MAINTAIN 36" COVER FROM FINAL GRADES TO TOP OF PIPE (EXCEPT WHEN ENTERING TELEPHONE BOXES). MAINTAIN 12" MINIMUM SEPARATION FROM FOREIGN UTILITIES. BOXES WILL BE ESTABLISHED TO FINISH GRADE.
5. ALL PULL BOXES (2'-0" X 3'-0" AND LARGER) AND MANHOLES ARE TO BE GROUNDING WITH A 3/8" x 1/16" TINNED SOFT COPPER BONDING RIBBON PLACED VERTICALLY AROUND THE BOTTOM OF THE BOX WITH 3" ENDS STUBBED INSIDE.
6. ALL TELEPHONE BOXES NOT IN SIDEWALK AREAS WILL BE REQUIRED TO HAVE A PROTECTIVE CONCRETE COLLAR, RE-ENFORCED WITH REBAR, POURED AROUND THE TOP PORTION OF THE BOX PER CENTURYLINK SPECIFICATIONS.
7. USE EXISTING PRECAST TERMINATORS TO JOIN SUBSTRUCTURES WHENEVER POSSIBLE. IF EXISTING TERMINATORS ARE NOT AVAILABLE THEN THE CONTRACTOR SHALL CORE DRILL, PLACE END BELLS AND PROPERLY GROUT THE CONDUIT INTO THE PRE-DETERMINED LOCATION. CONTACT THE CENTURYLINK INSPECTOR AT 244-7811, 24 HOURS IN ADVANCE TO DETERMINE THE EXACT ENTRANCE LOCATION. ENTERING THE SIDE OF A CENTURYLINK MANHOLE OR PULL BOX IS NOT PERMITTED UNLESS APPROVED BY CENTURYLINK.
8. WHEN A PULL BOX OR MANHOLE IS SITUATED WITHIN 50' OF A POWER TRANSFORMER, THE DEVELOPER/ CONTRACTOR SHALL PROVIDE AND INSTALL A #6 AWG STRANDED COPPER WIRE WITH GREEN PVC INSULATION FROM THE PULL BOX OR MANHOLE TO THE POWER TRANSFORMER (EXCLUDING 30' BOXES AND SMALLER). LEAVE A 4 FOOT TAILING END INSIDE THE SUBSTRUCTURE AND INCLUDE ALL CLAMPS NECESSARY TO FASTEN THE GROUNDING WIRE TO THE TRANSFORMER GROUND ROD OR COUNTERPOISE. THE GROUND WIRE SHALL ENTER THE SUBSTRUCTURE THROUGH THE 1" PVC GROUND SLEEVE.
9. WHEN JOINING EXISTING STUB-OUTS, THE LOCATION AND VALIDITY OF THE STUB-OUTS ARE ASSUMED AND BASED OFF RECORDS. IT SHALL BE THE CONTRACTOR'S RESPONSIBILITY TO DETERMINE THE EXACT HORIZONTAL AND VERTICAL LOCATION OF THE EXISTING CONDUIT STUB-OUT. THE CONTRACTOR SHALL BE RESPONSIBLE TO LOCATE, PROBE AND PLACE PULL STRING IN THE EXISTING CONDUIT AS PART OF CONNECTING TO THE STUB FOR EXTENSION TO THIS PROJECT. IF THE CONDUIT CANNOT BE PROVED OR IS IDENTIFIED AS BEING DAMAGED THEN THE CONTRACTOR SHALL BE RESPONSIBLE TO REPAIR THE DUCTS WHERE DAMAGED OR INSTALL NEW CONDUIT BACK TO THE EXISTING TRUE POINT OF RE-ENTERABLE SERVICE (i.e. POLE, MANHOLE OR PULL BOX) AT THE DEVELOPER'S EXPENSE.
10. THE CONTRACTOR SHALL PROBE AND MANHOLE ALL CONDUIT AFTER BACKFILLING WHILE A CENTURYLINK INSPECTOR IS PRESENT. MANHOLE SIZE IS TO BE 1/4" SMALLER THAN THE INSIDE DIAMETER OF THE CONDUIT.
11. THE CONTRACTOR SHALL PROVIDE AND INSTALL A MEASURING TAPE CONSISTING OF WATER PROOF, 400 POUND TENSILE STRENGTH, MARKED IN ONE FOOT OR LESS INCREMENTS IN AT LEAST ONE DUCT OF ALL CONDUIT SECTIONS. ALL OTHER DUCTS IN A MULTIPLE DUCT SYSTEM WILL HAVE A 3/32" JET LINE PULL STRING WITH 400 POUND TENSILE STRENGTH.
12. A POLYETHYLENE DUCT PLUG SHALL BE INSTALLED IN ALL CONDUIT WHERE TERMINATED OR STUBBED.
13. CONCRETE ENCASEMENTS SHALL CONSIST OF 3/4" AGGREGATE, TYPE V. PORTLAND CEMENT CONCRETE. THE ENCASEMENT SHALL BE A MINIMUM OF 2" BETWEEN THE CONDUIT AND A MINIMUM OF 3" ON THE TOP, BOTTOM AND SIDES OF THE DUCT BANK.
14. PROTECTIVE POSTS SHALL BE 4" RIGID STEEL PIPE, SIX FEET IN LENGTH, FILLED AND SET IN CONCRETE AT LOCATIONS SHOWN. THE TOP OF THE PROTECTIVE POST SHALL BE 36 INCHES ABOVE THE PROPOSED FINISHED GRADE AND PAINTED WITH YELLOW STREET MARKING PAINT.
15. PLYWOOD BACKBOARDS ARE TO BE TREATED WITH FIRE RETARDANT MATERIAL, PAINT, OR SEALER.
16. ALL TERMINALS, BACKBOARDS, CABINETS, ETC., SHALL BE EQUIPPED WITH A #6 GAUGE GROUND WIRE, RUN TO AN APPROVED GROUND SOURCE.
17. IN ORDER TO INSURE ADEQUATE FACILITIES ARE PROVIDED FOR THIS PROJECT, IT IS IMPERATIVE THAT THIS CONDUIT RECOMMENDATION NOT BE CHANGED WITHOUT CENTURYLINK OUTSIDE PLANT ENGINEERING APPROVAL.
18. CENTURYLINK WILL REQUIRE "AS-BUILT" FOOTAGES PRIOR TO ORDERING CABLE TO SERVE THIS DEVELOPMENT. THESE FOOTAGES MUST BE RECEIVED SIX WEEKS PRIOR TO SERVICE INSTALLATION DUE DATES.
19. CALL 244-7811 TO SCHEDULE INSPECTIONS 24 HOURS IN ADVANCE. REQUESTS RECEIVED AFTER 11:00 AM MAY NOT BE SCHEDULED FOR THE FOLLOWING WORKDAY.

**CONTRACTOR / DEVELOPER NOTE**

1. THE DEVELOPER/CONTRACTOR SHALL CALL 244-7811 TO SCHEDULE INSPECTIONS 24 HOURS IN ADVANCE. REQUESTS RECEIVED AFTER 11:00 AM MAY NOT BE SCHEDULED FOR THE FOLLOWING WORKDAY.
2. ANY MODIFICATIONS TO THE CENTURYLINK DESIGN MUST BE APPROVED BY THE ENGINEER.
3. THESE PLANS WILL BE VALID FOR SIX MONTHS FROM DATE OF ISSUE.

CITY OF LAS VEGAS DEVELOPER/CONTRACTOR SHALL OBTAIN A CITY PERMIT BEFORE ANY EXCAVATION WORK WITHIN CITY OF LAS VEGAS RIGHT-OF-WAY *CENTURYLINK INSPECTOR WILL VERIFY CITY PERMIT FOR WORK DONE WITHIN CITY OF LAS VEGAS RIGHT-OF-WAY INSPECTOR: _____ DATE: _____	<b>EASEMENT / PERMIT CERTIFICATION</b> EASEMENT / PERMIT REQUIRED: YES <input type="checkbox"/> NO <input checked="" type="checkbox"/> EASEMENT / PERMIT OBTAINED: YES <input type="checkbox"/> NO <input checked="" type="checkbox"/> DATE EASEMENT / PERMIT OBTAINED: _____ ROW ENGINEER SIGNATURE: _____ CENTURYLINK EASEMENT/PERMIT NUMBER: _____ REMARKS: _____	OWNER/CONTACT: <u>RICH RIAL</u> TELEPHONE: <u>702-376-0527</u>  ORIGINAL BY: <u>LORI JOHNSON</u> 5/29/13 REVIEWED BY: <u>OSP ENGINEER</u> DATE _____  APPROVED BY: _____ DATE _____
---	--	---

NO.	REVISION	ENGR. MGR. DATE

CENTURYLINK PROPRIETARY

CONSTRUCTION PERMIT REQUIRED BY CONTRACTOR

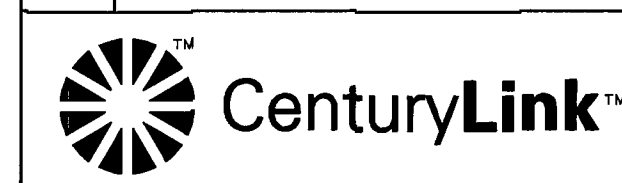

FILE: UNDERGROUND CONDUIT	ENGR: M. SOMMA	C.A. #: E-488089
PROJECT: REQUIREMENT FOR	PHONE: 244-1726	C.O. #: NORTH 8
BY: VOLUNTEERS IN MEDICINE	DATE: 5/29/13	SCALE: 1" = 30'
MARTIN L KING/MADISON	SHEET: 3	OF 3



Know what's below. Call before you dig.

