

GENERAL NOTES FOR T&S

- ALL CONSTRUCTION SHALL CONFORM TO EMBARQ TELEPHONE COMPANY SPECIFICATIONS ISSUED MAY 1, 2003 FOR THE INSTALLATION OF UNDERGROUND RESIDENTIAL DISTRIBUTION TELEPHONE SYSTEM.
- ALL TRENCHING, BACKFILLING AND SUBSTRUCTURES ARE TO BE PROVIDED BY THE DEVELOPER AND CONFORM WITH EMBARQ STANDARDS.
- TRENCHING AND TELEPHONE BOXES ARE TO BE PLACED IN THE SIDEWALK AREA WHENEVER POSSIBLE. ALL TRENCHING WILL BE OF A MINIMUM DEPTH TO MAINTAIN A 36" COVER OVER ALL TELEPHONE FACILITIES AND 12" MINIMUM SEPARATION FROM FOREIGN UTILITIES. BOXES WILL BE ESTABLISHED TO FINISH GRADE.
- TRENCHING FOR STREET CROSSINGS IS TO BE OF A DEPTH NECESSARY TO MAINTAIN 36" COVER OVER TELEPHONE FACILITIES FROM FINISH GRADE AND 12" MINIMUM SEPARATION FROM FOREIGN UTILITIES. IF THE MINIMUM COVER CAN NOT BE PROVIDED, CONDUIT MUST BE PLACED AND CONCRETE ENCASUREMENT IS REQUIRED PER EMBARQ SPECIFICATIONS AT DEVELOPER'S EXPENSE.
- TRENCH AND SUBSTRUCTURE TO BUILDING MUST BE 18" FROM PROPERTY LINE WITH A MINIMUM DEPTH TO MAINTAIN 36" COVER FROM FINISH GRADE AND 12" MINIMUM SEPARATION FROM FOREIGN UTILITIES. WHEN THE TRENCH WILL BE UNDER PAVEMENT, DEVELOPER IS TO PROVIDE 1" CONDUIT UNDER PAVED AREA AT THE DEVELOPER'S OWN EXPENSE.
- ALL TELEPHONE BOXES THAT ARE SUBJECT TO VEHICULAR TRAFFIC WILL BE REQUIRED TO HAVE A PROTECTIVE 8' X 8' CONCRETE COLLAR POURED AROUND THE TOP PORTION OF THE BOX PER EMBARQ SPECIFICATIONS. (THIS WILL APPLY TO DIRT AND GRASSED AREAS ALSO.)
- ANY CONDUIT PLACED FOR DEVELOPER'S CONVENIENCE (I.E. STREET CROSSING, STUB-OUTS FOR FUTURE UNITS) WILL BE PLACED AT DEVELOPER'S EXPENSE.
- CABLE RACKS WILL BE INSTALLED IN ALL 2 1/2' X 4' X 4' PULL BOXES AND LARGER PER EMBARQ SPECIFICATIONS.
- ANY PULL BOX PLACED NEAREST TO A POWER TRANSFORMER WILL BE REQUIRED TO HAVE A #6 COPPER GROUND WIRE WITH A GREEN PVC INSULATION SHEATH PLACED BY THE CONTRACTOR FROM THE PULL BOX TO THE POWER TRANSFORMER GROUND ROD AND ATTACHED TO PROVIDE A COMMON GROUND WITH THE POWER COMPANY. THIS GROUND WIRE AND ATTACHING CLAMP WILL BE PROVIDED BY THE TELEPHONE COMPANY AND CAN BE OBTAINED FROM THE INSPECTOR.
- THE DEVELOPER SHALL PROVIDE A #6 COPPER GROUND WIRE FROM EACH TERMINAL CABINET TO A COMMON GROUND WITH NEVADA POWER COMPANY PER THE NATIONAL ELECTRICAL SAFETY CODE SPECIFICATIONS.
- IN SOME CASES A PULL BOX MAY HAVE TO BE RELOCATED FROM THE POSITION SHOWN ON THE DRAWING DUE TO INTERFERENCE WITH OTHER UTILITIES SUCH AS STREET LIGHTS, ETC. IF SUCH RELOCATION IS REQUIRED, THE ENGINEER SHALL BE NOTIFIED PRIOR TO RELOCATION.
- ALL PULL BOXES (2 1/2' X 4' AND LARGER) AND MANHOLES ARE TO BE GROUNDED WITH A 3/8" X 1/16" TINNED SOFT COPPER BONDING RIBBON PLACED VERTICALLY AROUND THE BOTTOM OF THE BOX WITH 3' ENDS STUBBED INSIDE.
- WHEN EXISTING TELEPHONE FACILITIES (POLES, MANHOLES, PULL BOXES, CONDUIT, TERMINALS, ETC.) ARE AFFECTED BY IMPROVEMENTS (REQUIRED BY LOCAL ORDINANCE, E.G. STREETS, SIDEWALKS, GUTTERS, ETC.) THE DEVELOPER SHALL BE RESPONSIBLE FOR THE ADJUSTMENT OF THESE FACILITIES AS REQUIRED.
- CALL 244-7811 TO SCHEDULE INSPECTIONS TWENTY-FOUR HOURS IN ADVANCE. REQUESTS RECEIVED AFTER 11:00 AM MAY NOT BE SCHEDULED FOR THE FOLLOWING WORK DAY.
- ALL 2 1/2' X 4' AND 3' X 5' PULL BOXES MUST BE INTERCEPT TYPE BOXES. BASE PORTION MUST BE SET PRIOR TO CABLE PULL. UPPER PORTION WILL BE PLACED AFTER CABLE PULL AND PRIOR TO SPLICING.
- ALL STUB-OUTS FROM PULL BOXES TO BACK OF SIDEWALK FOR SERVICE DROP WILL BE AT DEVELOPER'S OPTION AND EXPENSE.
- ALL PEDESTALS WILL BE PLACED NO CLOSER THAN 18" TO THE SIDE OF POWER TRANSFORMERS.
- THE CONTRACTOR / DEVELOPER SHALL INSTALL A TAPERED POLYETHYLENE DUCT PLUG WITH PULL STRING TAB IN ALL CONDUIT. TERMINATED OR CAPPED ASSOCIATED WITH THIS PROJECT.

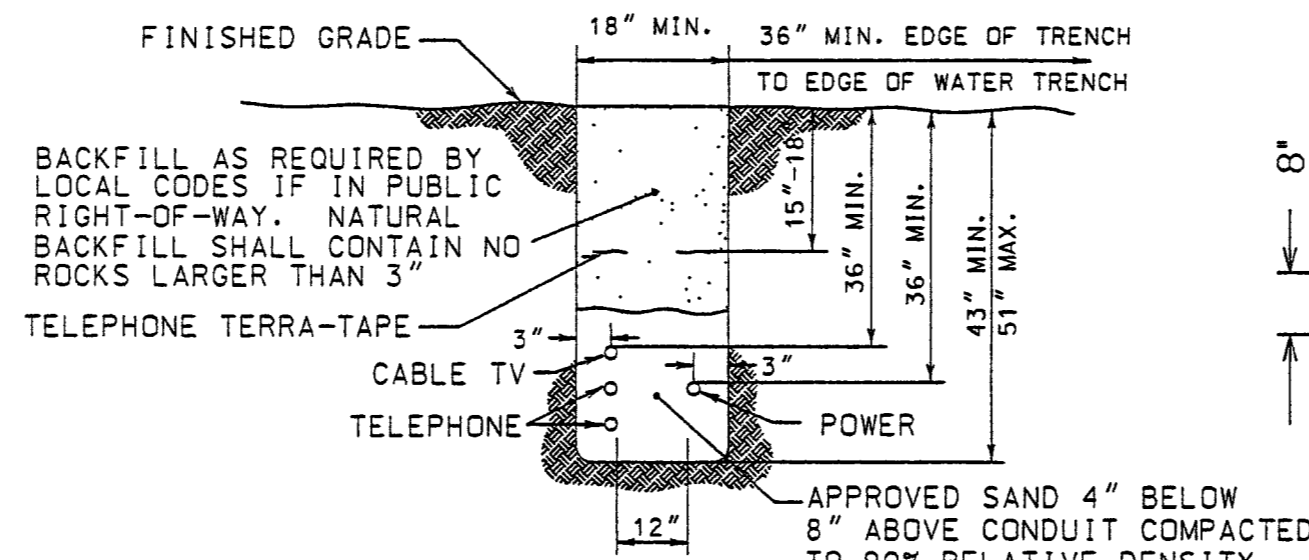

ONSITE TRENCH DETAIL WITHOUT SIDEWALK

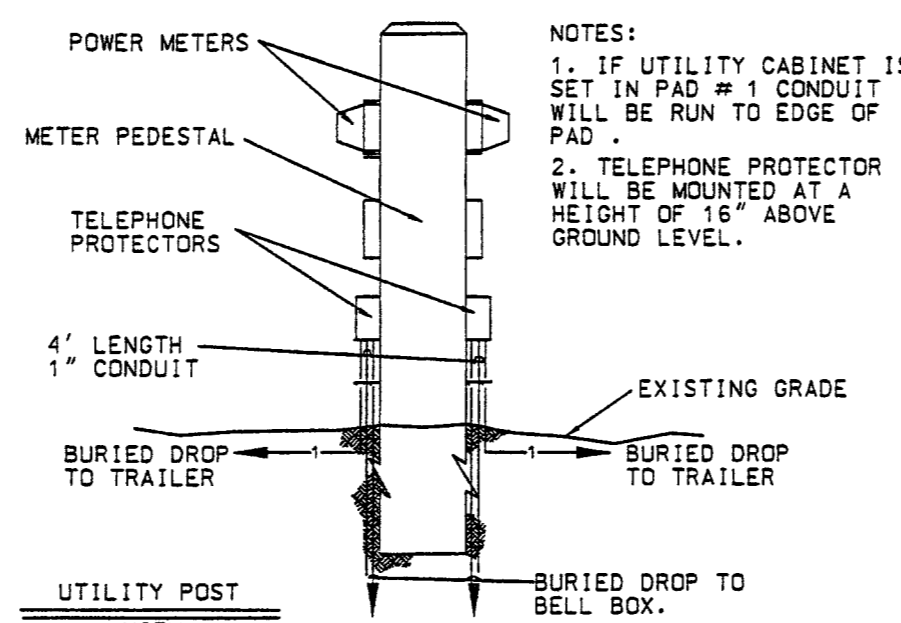

TRAILER PARK DETAIL (TYP.)

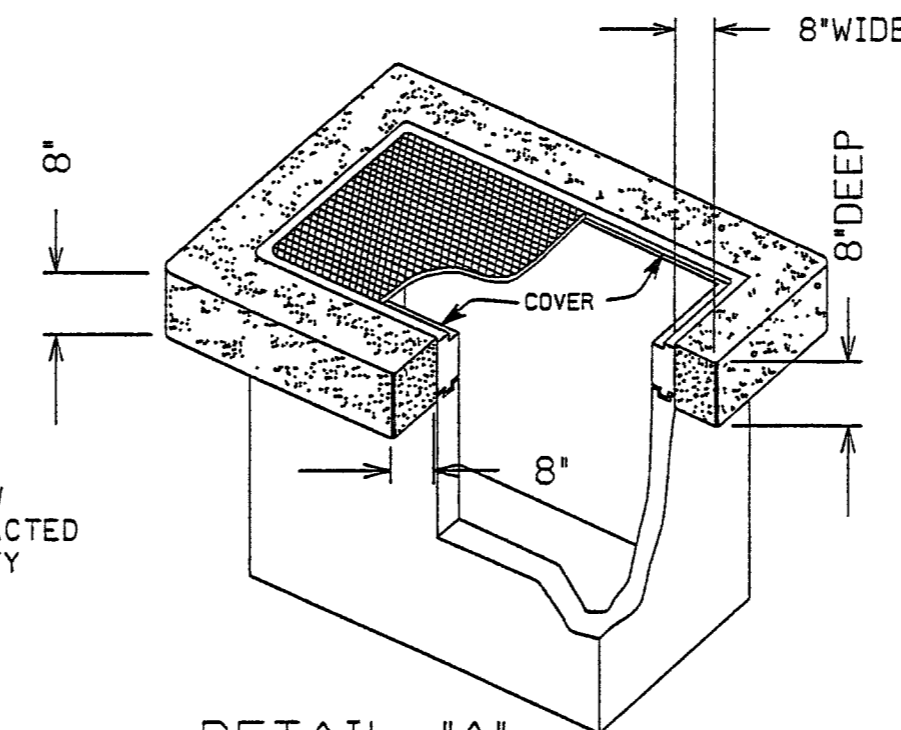

DETAIL "A"
6'X8' COLLAR EF-30 BOX
8'X8' COLLAR 200 BOX OR LARGER

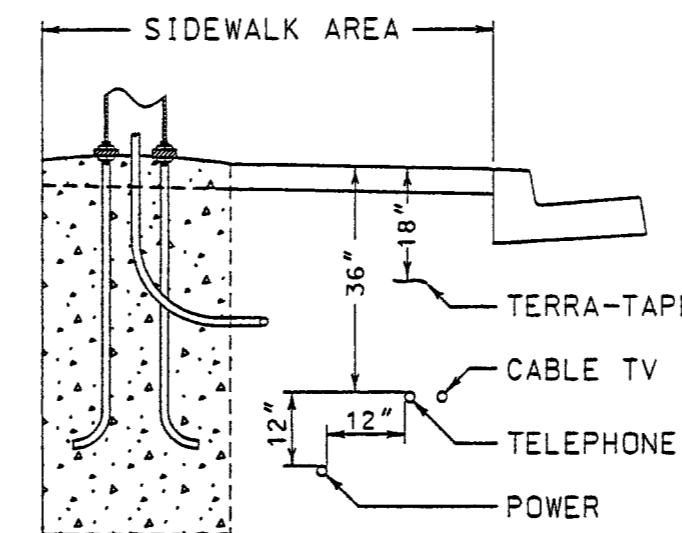

OFFSITE TRENCH DETAIL WITH SIDEWALK

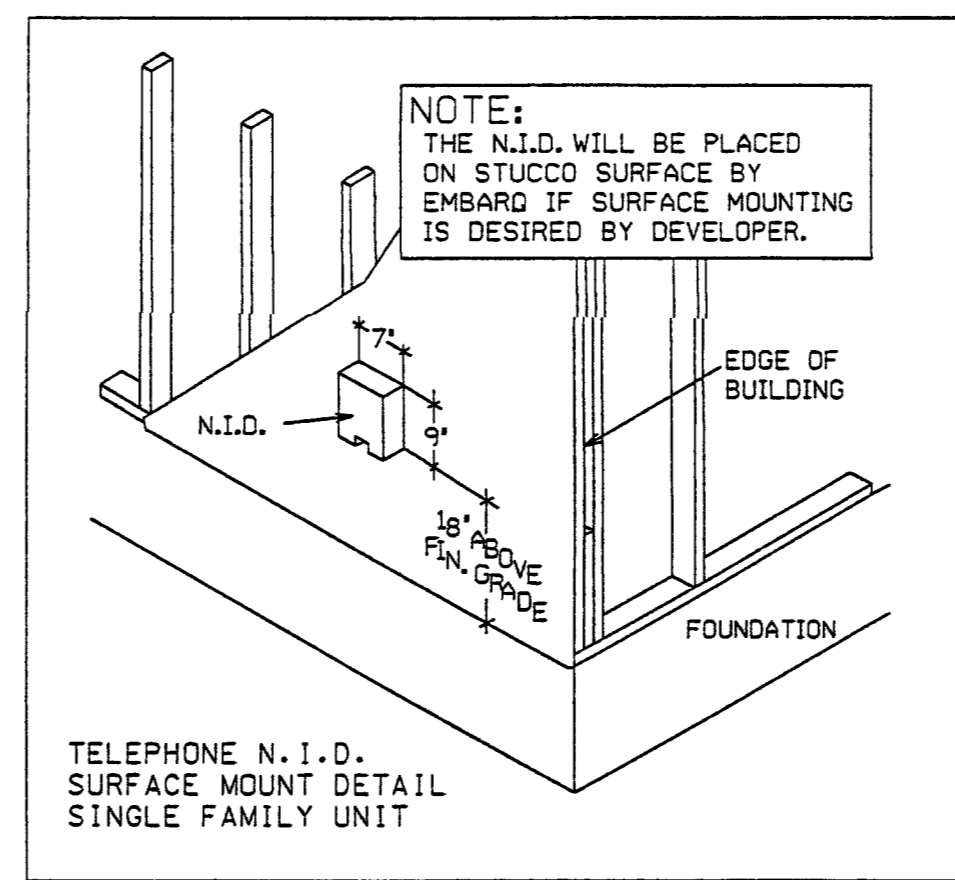
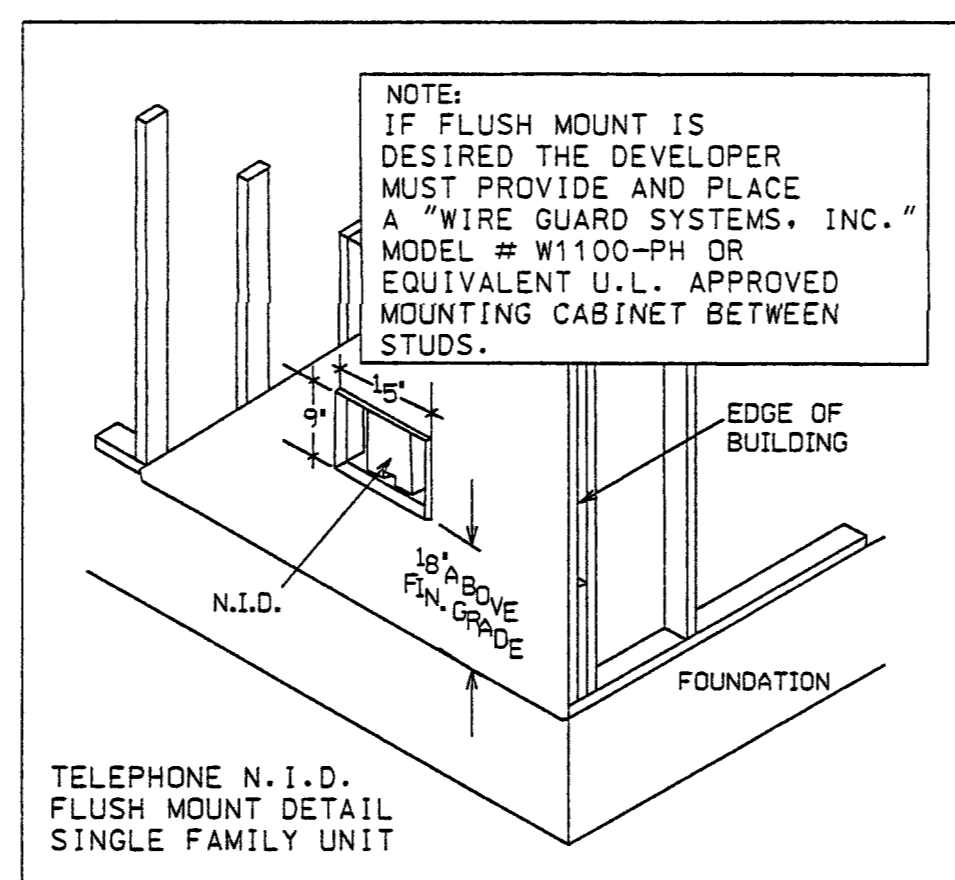

CONTRACTOR/DEVELOPER NOTE:

ALL WORK REQUIRED OF YOU (TRENCHING, BOXES, CONDUIT, GROUTING, GROUNDING, TERMINALS, ETC.) MUST BE COMPLETED AND INSPECTED A MINIMUM OF 45 DAYS PRIOR TO MOVE-IN IF OUR CUSTOMERS ARE TO HAVE TELEPHONE SERVICE WITHOUT DELAY.

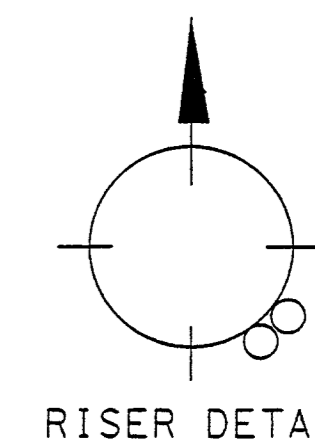

**CONSULT EMBARQ TELEPHONE COMPANY SPECIFICATION FOR 3'X5'X4' PULLBOX TO DETERMINE WHETHER "TORSION ASSIST" OR "BEAM AND PLATE" COVER WILL BE UTILIZED.

SPECIAL NOTE:

ANY MODIFICATIONS TO EMBARQ TELEPHONE'S DESIGN MUST BE APPROVED BY THE:

ENGINEER: *Randy Booth*

TEL#: 702 244-7675

CITY OF LAS VEGAS PERMIT REQUIRED*	
DEVELOPER/CONTRACTOR SHALL OBTAIN A CITY PERMIT BEFORE ANY EXCAVATION WORK WITHIN CITY OF LAS VEGAS RIGHT-OF-WAY	
* EMBARQ INSPECTOR WILL VERIFY CITY PERMIT FOR WORK DONE WITHIN CITY OF LAS VEGAS RIGHT-OF-WAY	
INSPECTOR:	DATE

AVAILABLE AT SPRING MTN. YARD CALL 244 4130

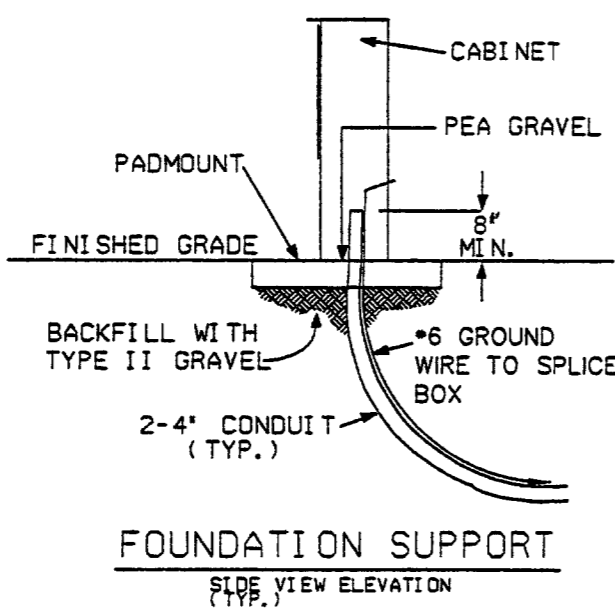

NOTE:

CALL 244-7811 BETWEEN 7 A.M. AND 11 A.M. 24 HOURS IN ADVANCE FOR INSPECTION

NOTE:

THESE PLANS WILL EXPIRE SIX MONTHS FROM DATE OF ISSUE

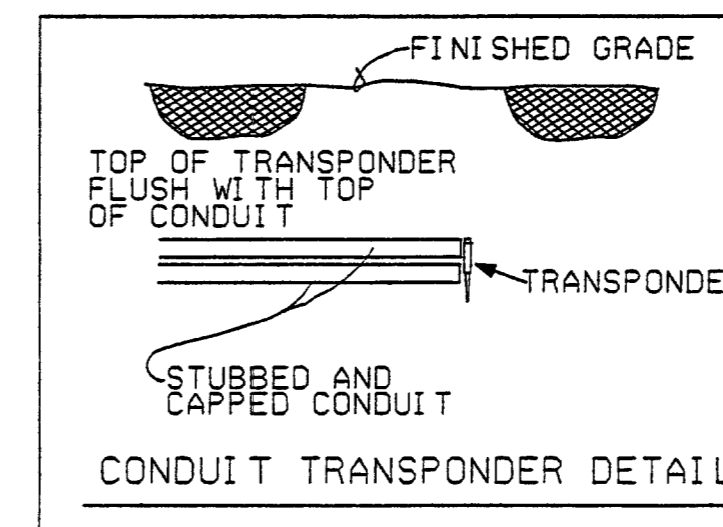
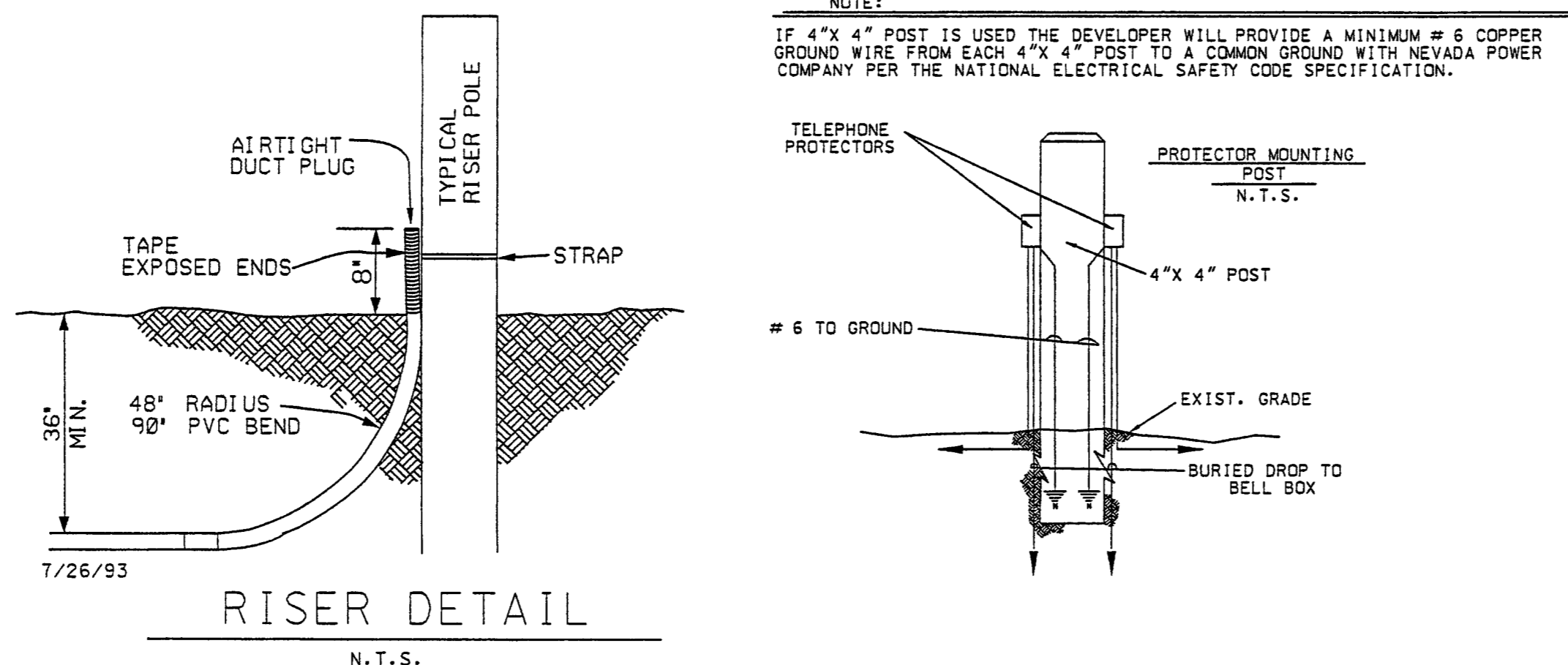

NO.	REVISION	ENGR.	MGR.	DATE	Avoid cutting underground utility lines. It's costly.
1					<p>Call before you Dig.</p> <p>1-800-227-2600</p> <p>UNDERGROUND SERVICE (USA)</p>
2					
3					
<p>TITLE: TRENCH & SUBSTRUCTURE REQUIREMENT for NORTHERN TERRACE UNIT 1</p> <p>ENGR. <i>Randy Booth</i> 24191447</p> <p>PHONE 702 244-7675</p> <p>LOC. NTS</p> <p>SCALE NTS</p> <p>EXCH. <i>NORTH5</i> C.D. <i>L.V.G.S</i></p>					<p>SH. 2 of 3</p>

96050

1074891-1-SPK