

NOTE: NEW SIDEWALK NOT INCLUDED IN THIS CONTRACT

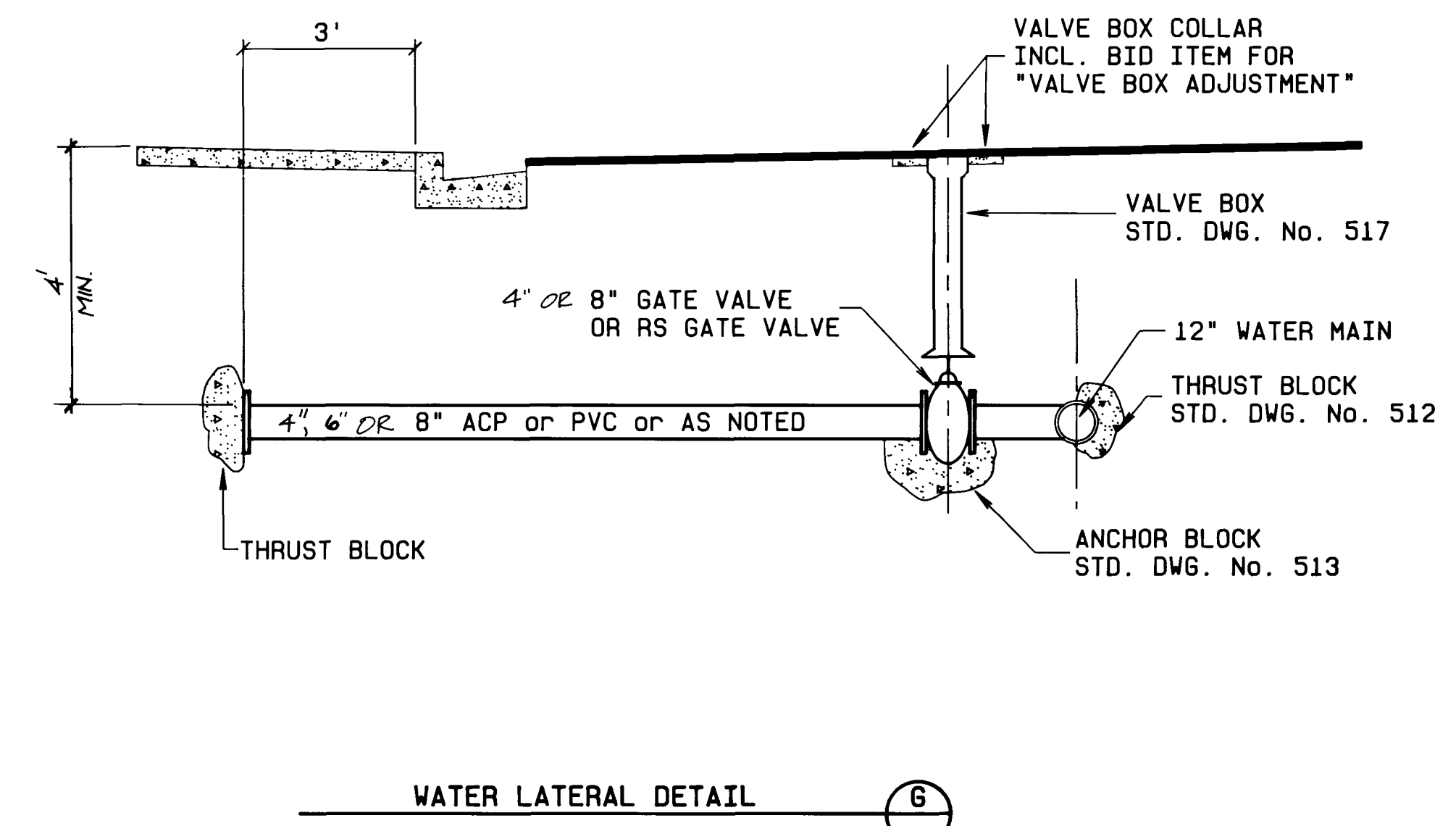
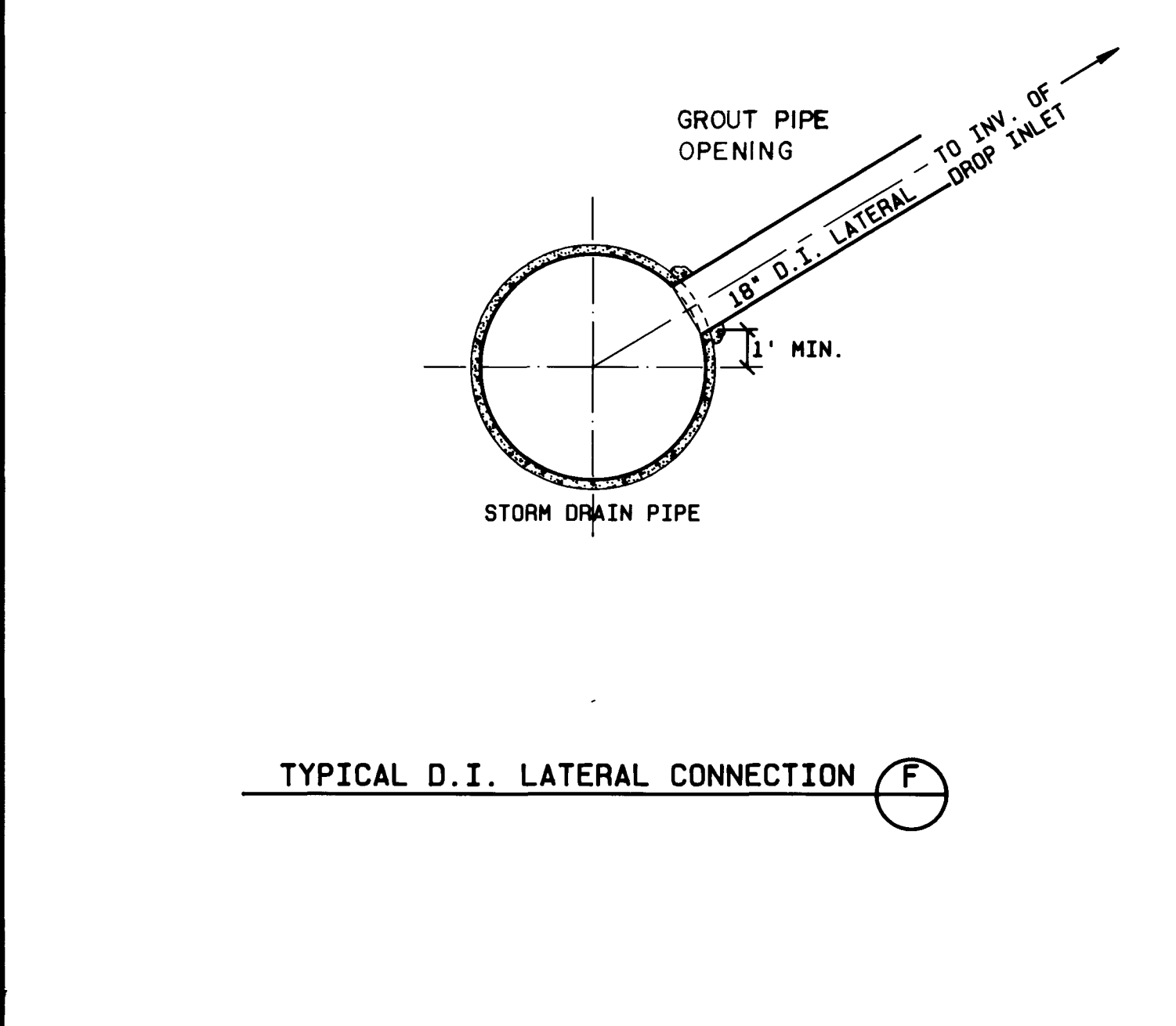
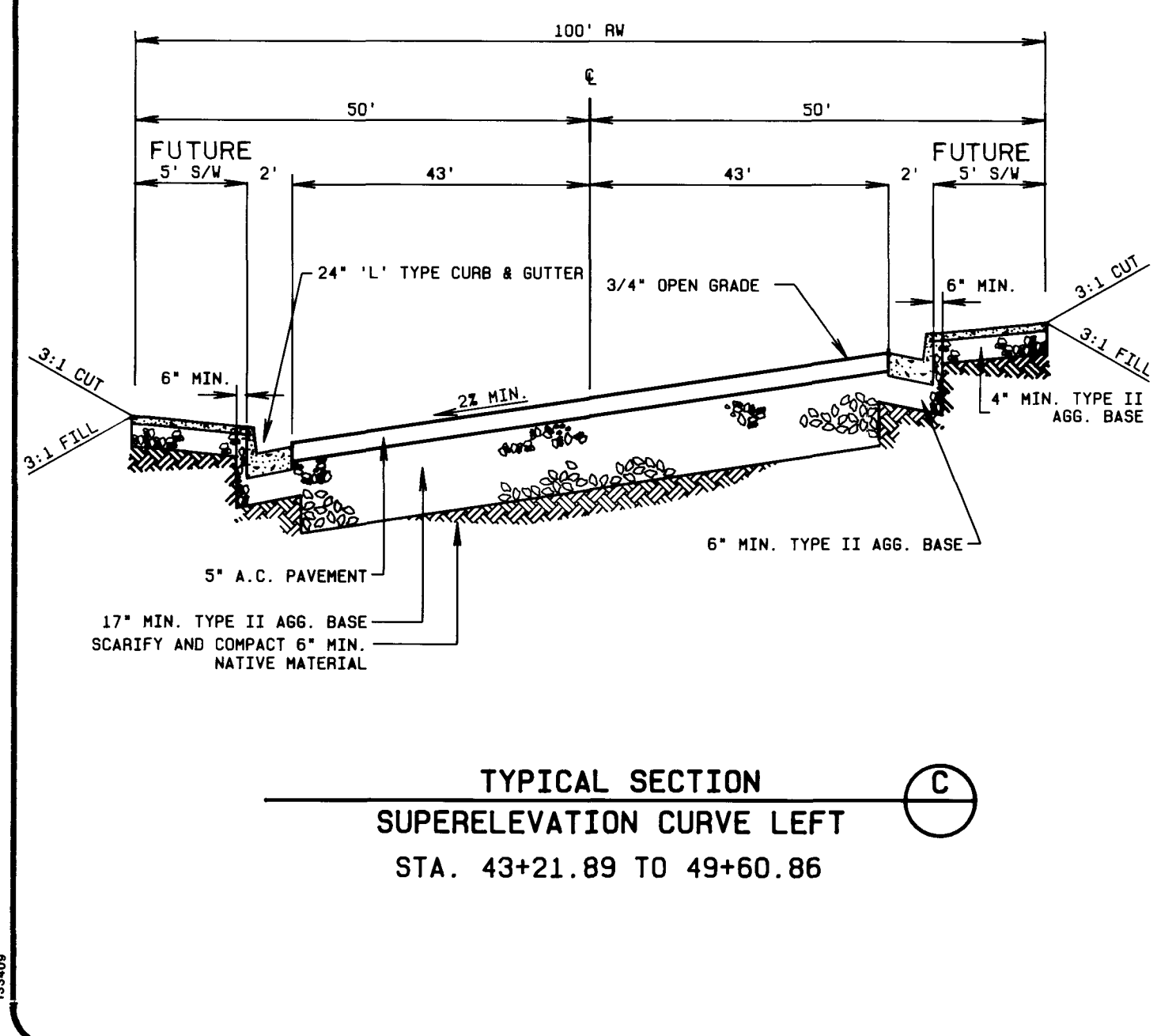
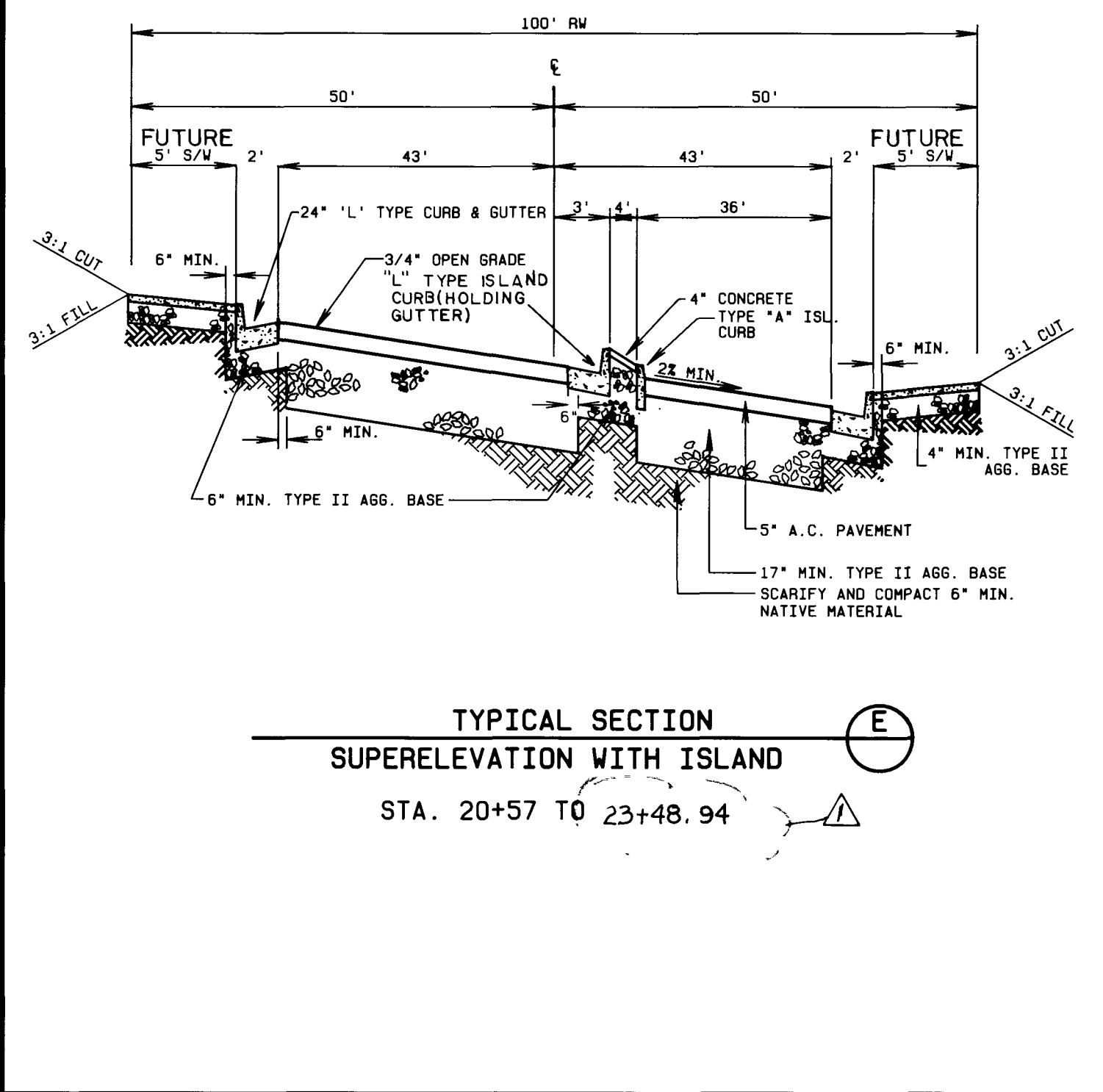
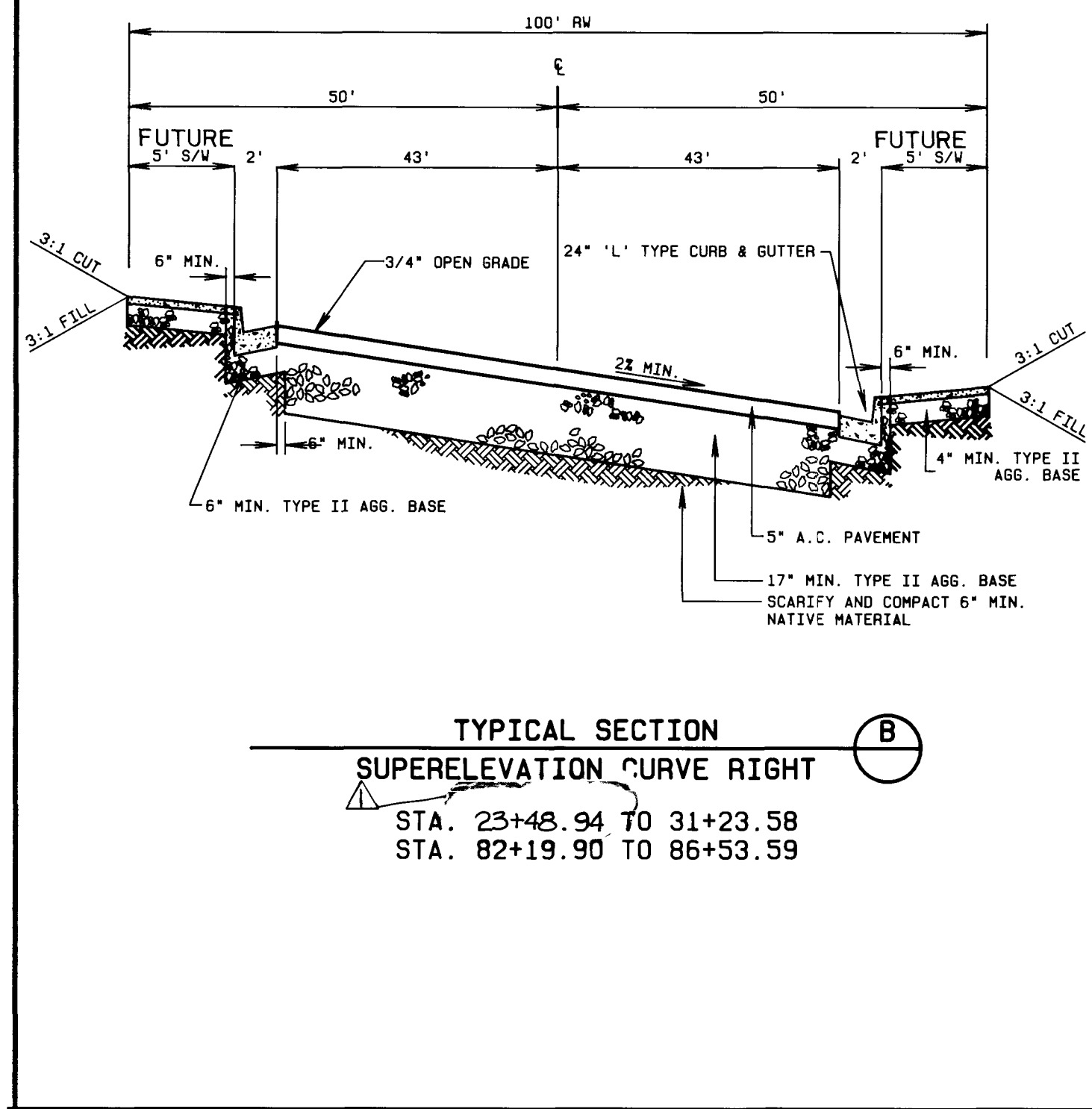

REV.	DATE	BY	REVISION

PROJECT: CITY OF LAS VEGAS, LAS VEGAS, NEVADA

PLANNERS - ENGINEERS CONSULTING  
2300 PASEO DEL PRADO, BUILDING A, SUITE 100  
LAS VEGAS, NEVADA 89102 PHONE (702) 873-7550

vtm nevada

TITLE: TYPICAL STREET SECTIONS AND DETAILS

PROJECT: LAKE MEAD BOULEVARD RANCHO TO TONOPAH

NO. NO. 3661  
BY D. L. A.  
DATE 9/10/90  
SCALE NONE

SHEET 3 OF 34 SHEETS

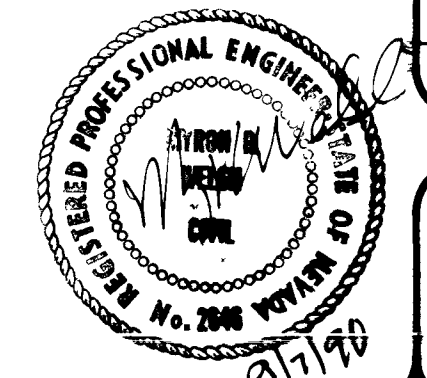

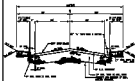

TYPICAL SECTION  
 SIDEWALK  
 10'-0" CURB  
 1'-0" GUTTER  
 1'-0" SIDEWALK

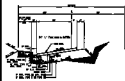

TYPICAL SECTION  
 10'-0" CURB - 1'-0" GUTTER

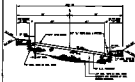

TYPICAL SECTION  
 SIDEWALK  
 10'-0" CURB  
 1'-0" GUTTER  
 1'-0" SIDEWALK

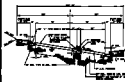

TYPICAL SECTION  
 SIDEWALK  
 10'-0" CURB  
 1'-0" GUTTER  
 1'-0" SIDEWALK

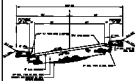

TYPICAL SECTION  
 SIDEWALK  
 10'-0" CURB  
 1'-0" GUTTER  
 1'-0" SIDEWALK



TYPICAL 3'-0" DIAM. MANHOLE

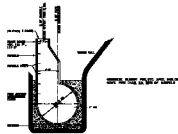

TYPICAL SECTION  
 SIDEWALK  
 10'-0" CURB  
 1'-0" GUTTER  
 1'-0" SIDEWALK

SEE SEE SHEETS FOR DETAILS OF THE CURBWAY

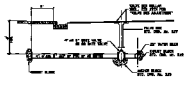

TYPICAL SECTION  
 SIDEWALK  
 10'-0" CURB  
 1'-0" GUTTER  
 1'-0" SIDEWALK

CITY OF LAKE MEAD  
 LAKE MEAD, ARIZONA  
 LAKE MEAD BOULEVARD  
 PROJECT NO. 100-100-100-100  
 SHEET NO. 100-100-100-100  
 DATE 10-10-10

TYPICAL STREET SECTIONS  
 AND DETAILS  
 LAKE MEAD BOULEVARD  
 PROJECT NO. 100-100-100-100

100-100-100-100  
 100-100-100-100  
 100-100-100-100  
 100-100-100-100

