

FED. RD. REG. NO.	STATE	PROJECT NO.	COUNTY	SHEET NO.
9	NEVADA	M-610(5)	CLARK	18

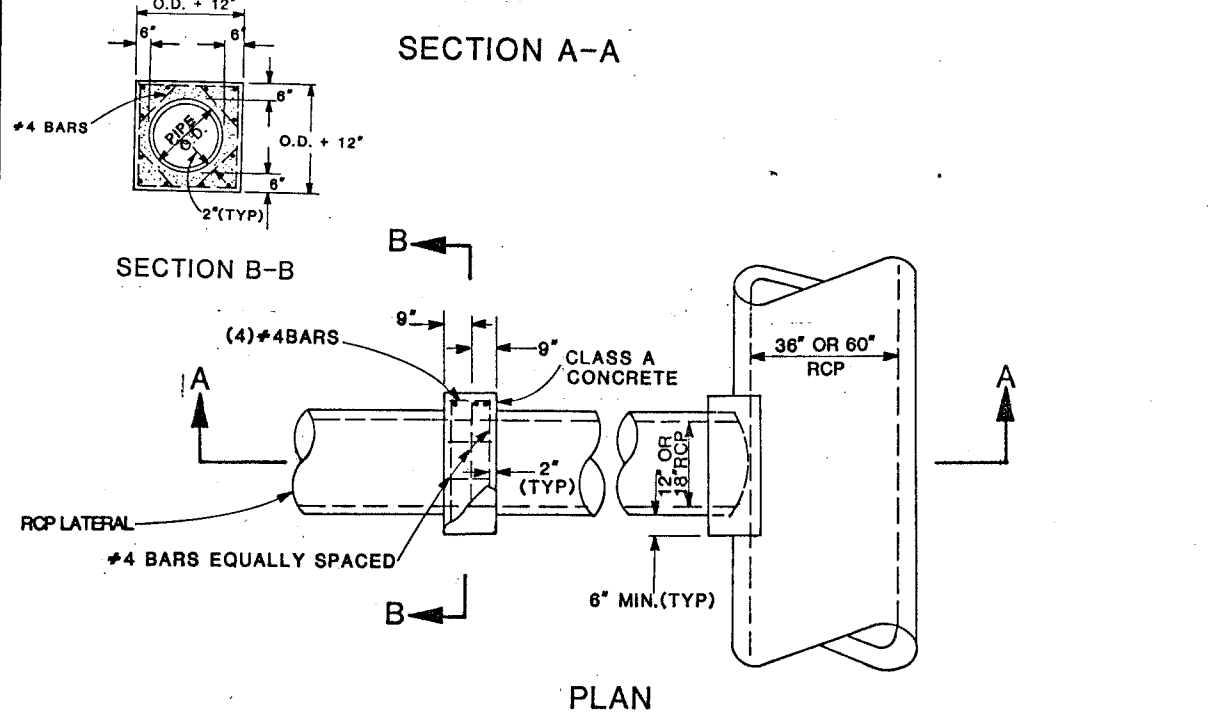
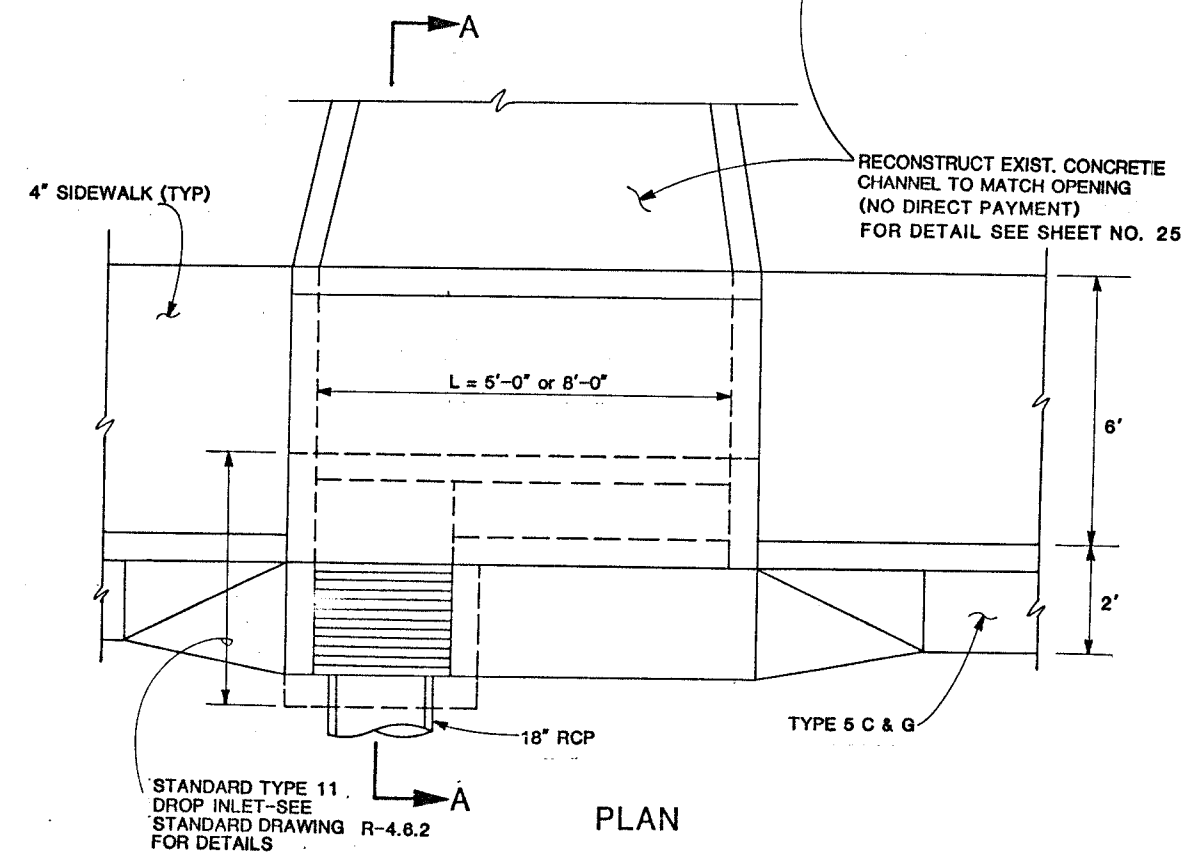
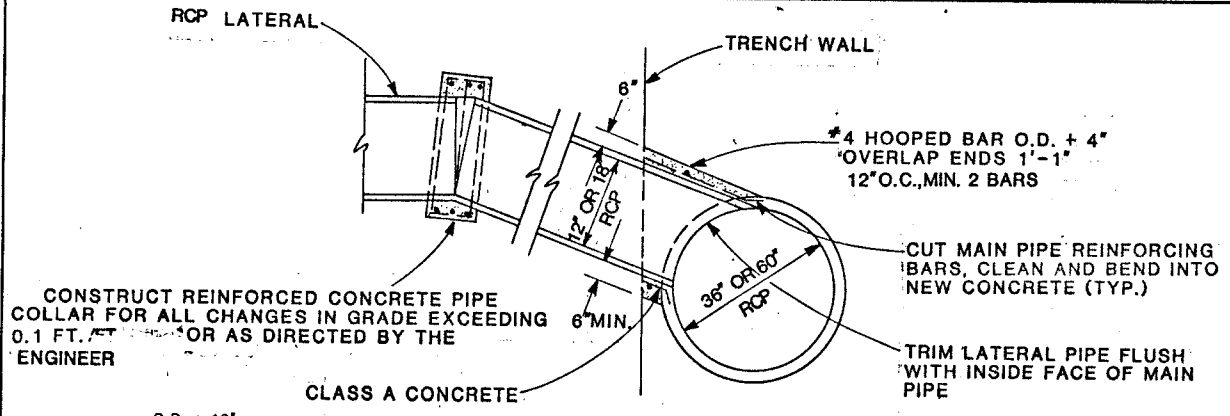
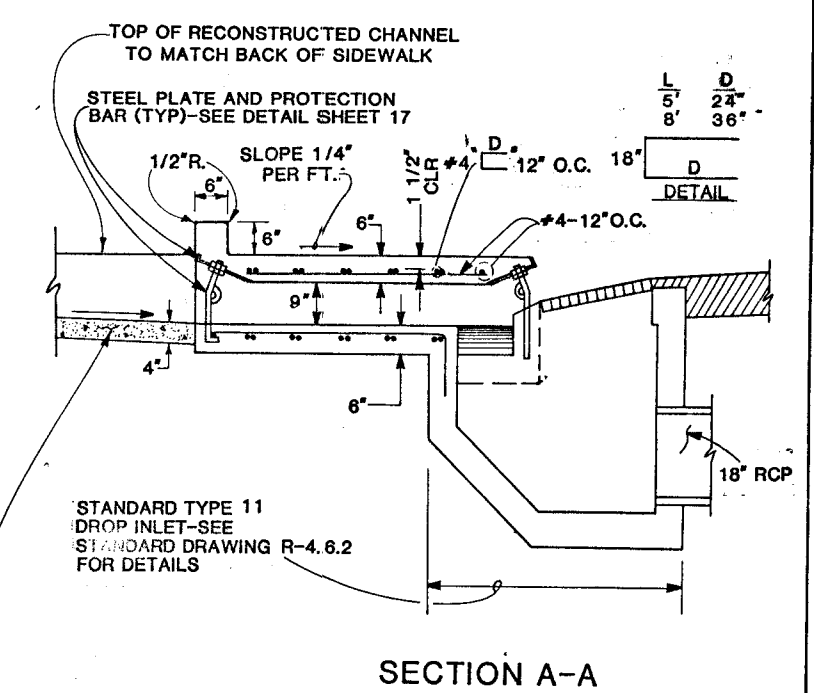
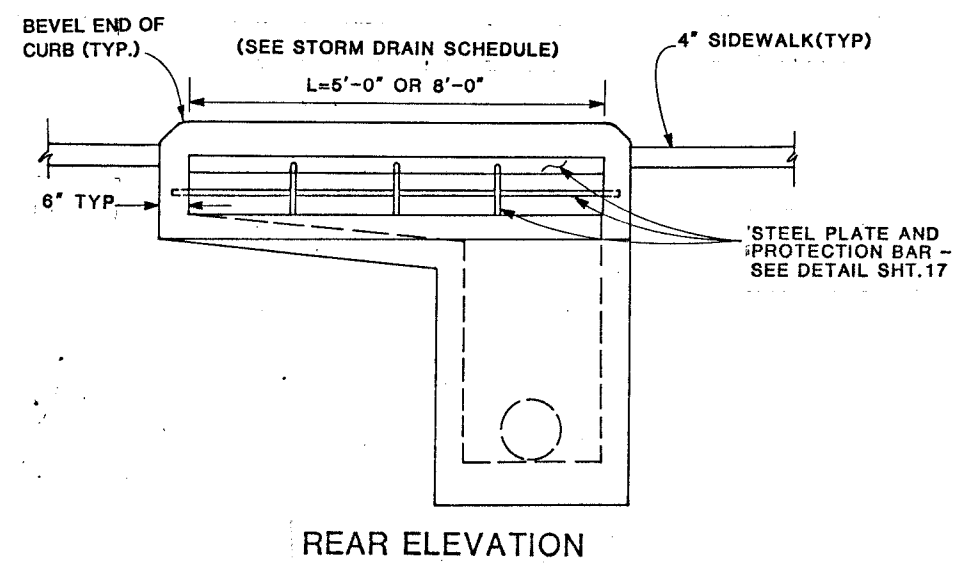
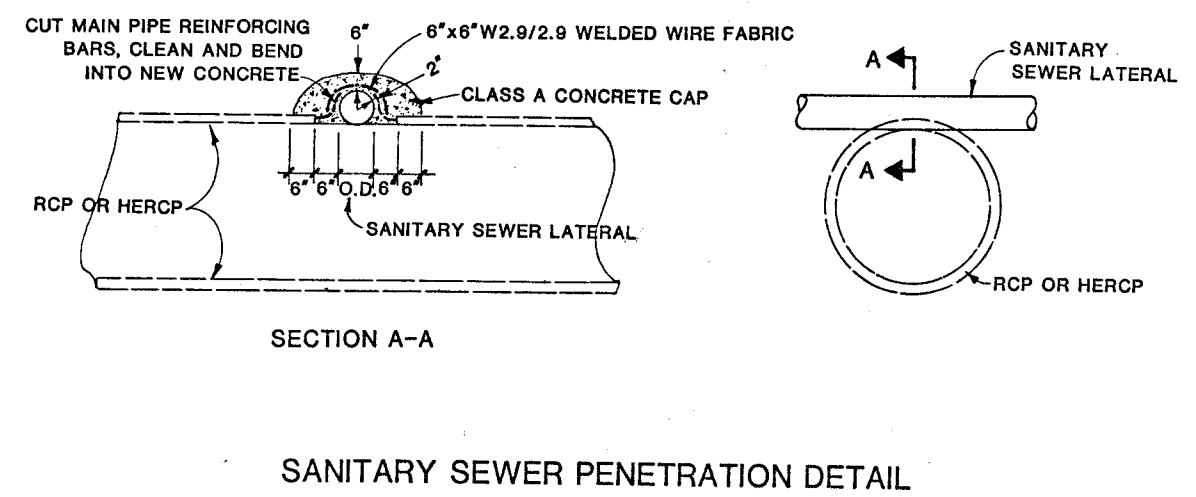

	JOB NO. 990-02-2
	DESIGNED GS
	DRAWN BMH
	CHECKED <i>[Signature]</i>
	DATE 3-30-90

STATE OF NEVADA
DEPARTMENT OF TRANSPORTATION

SPECIAL DETAILS

10743989

66926