

STREET LIGHT DETAIL N.T.S.

PER CLARK COUNTY AREA STANDARD DWG. NO. 320

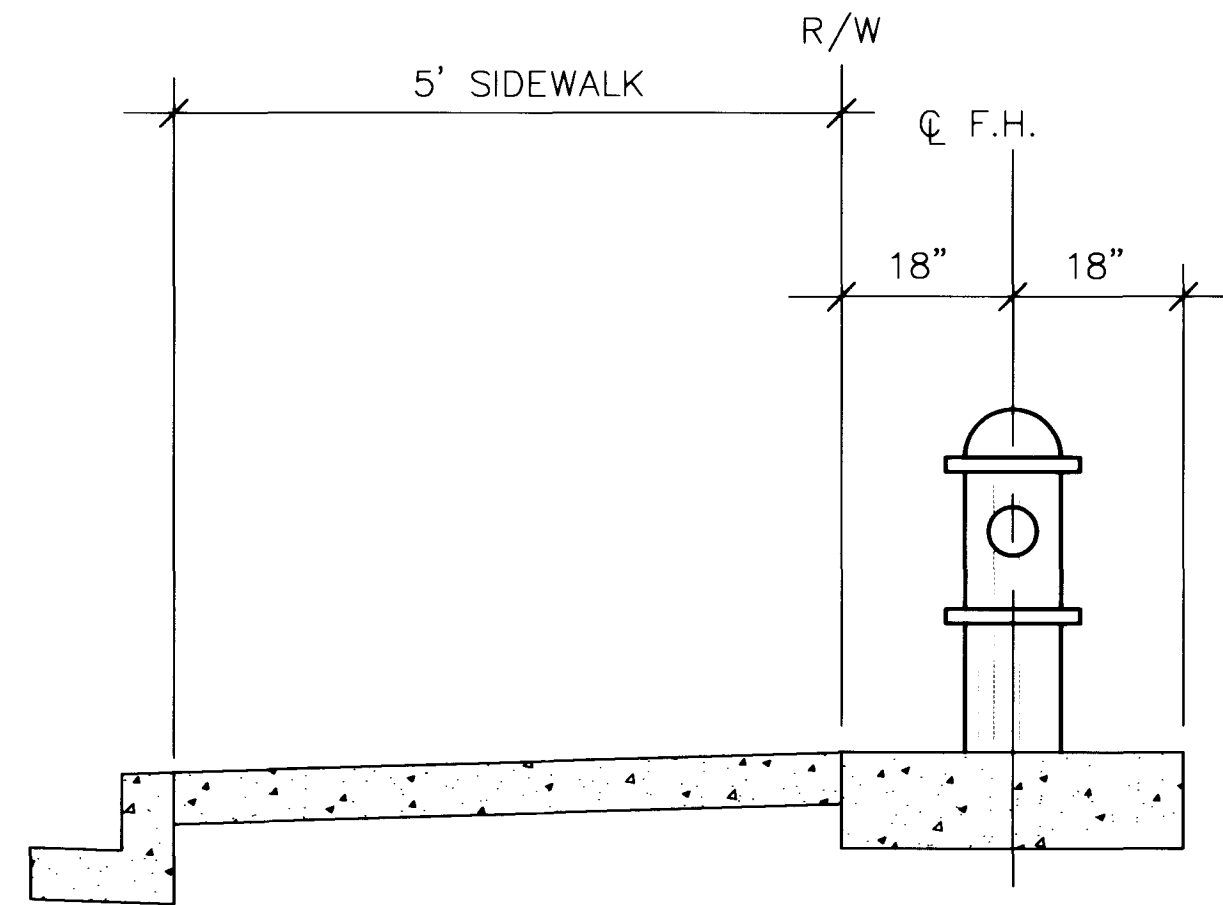

TYPICAL FIRE HYDRANT LOCATION

N.T.S. PER U.S.D. PLATE NO. 7

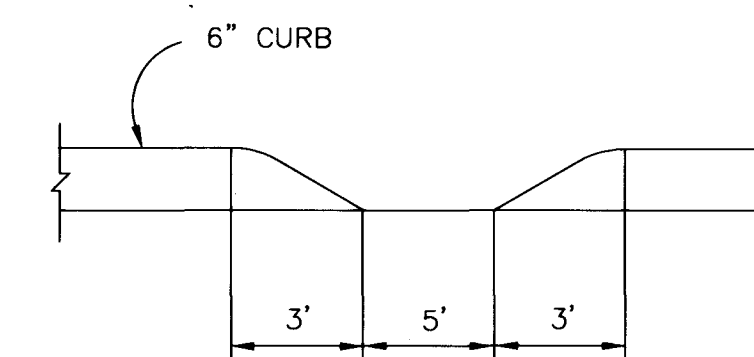

CURB TRANSITION

N.T.S.

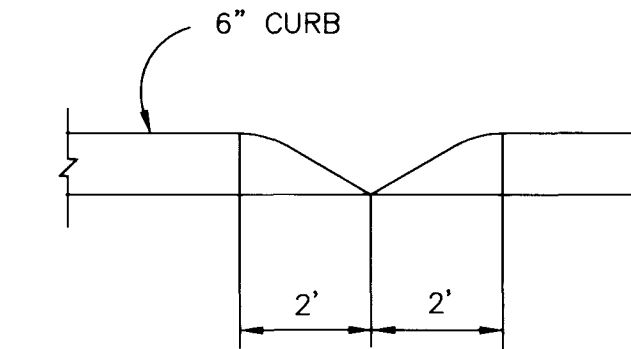

CURB OPENING

N.T.S.

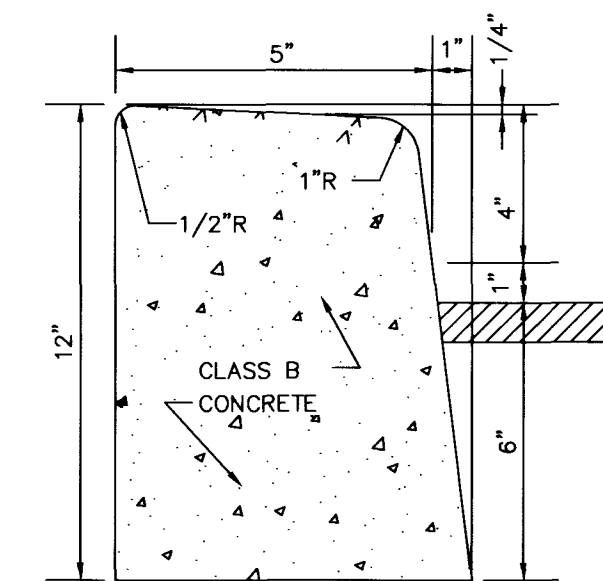

"A" CURB SECTION

N.T.S.

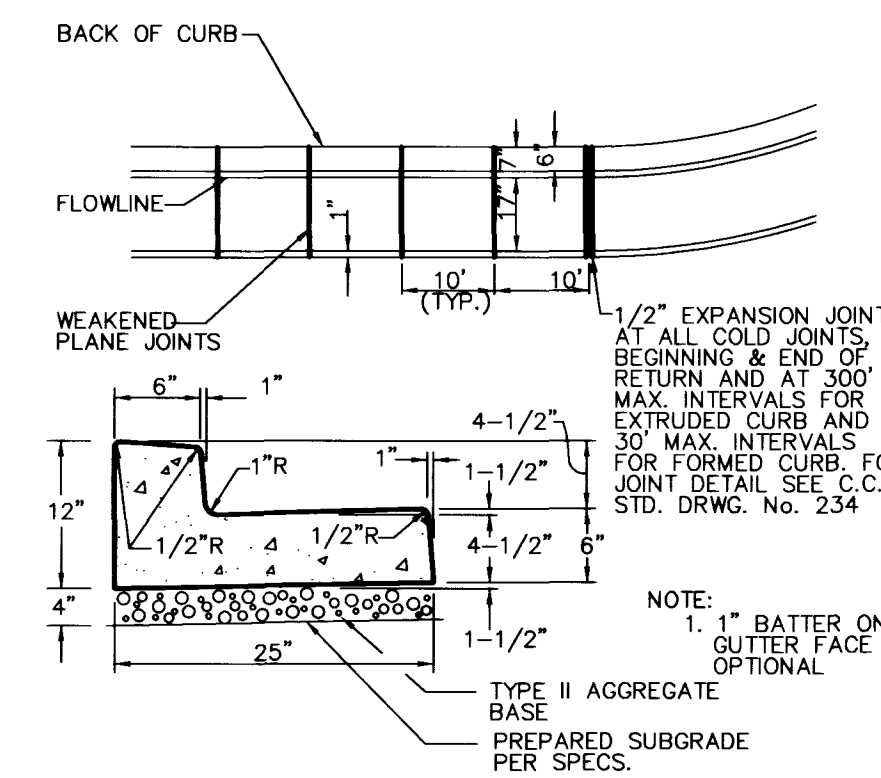

"L" TYPE CURB AND GUTTER

N.T.S.

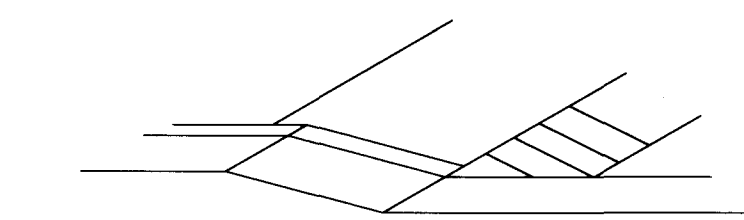

CURB RAMP

N.T.S.

REV	DATE	BY	REVISION

TRICON
5767 MOCKINGBIRD LANE
PARADISE VALLEY, ARIZONA
(602) 609-8745

CRS CONSULTING ENGINEERS OF NEVADA, INC.
CALVELL RICHARDS SORESEN

6700 S. PARADISE RD., # A-1
LAS VEGAS, NEVADA 89119
PHONE (702) 897-2825
FAX (702) 897-2826

DETAIL SHEET
SHEET

TITLE
KFC AT MARYLAND/SAHARA

DRAWN BY: S.S.	9-98
DESIGNED BY: KS	9-98
CHECKED BY: D.D.W. / JETZU	10-98
PROJECT NO: 30-22871	SCALE: 1" = NTS 1" = NTS VERT.

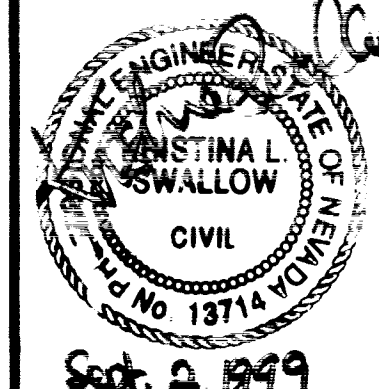

SHEET
C6

06 OF 06 SHEETS

DRAWING NO.
107-V3013

F:\2871\DRAWING\NCS\PH1\2871011.dwg Mon Jan 25 11:14:56 1999 CRS - RIM

17931 18245

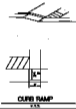
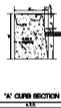
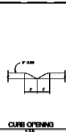
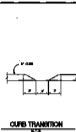
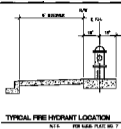
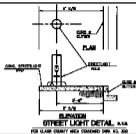

DETAIL OF SHEET STREET 1" = 12" AT BAYVIEW/BRANDEN	
DATE: _____ DRAWN BY: _____ CHECKED BY: _____ SCALE: _____	

