

UPPER RIGHT CORNER

SEE SHEET T-1

MATCHLINE STA 43+50.00

MATCHLINE STA 32+00.00

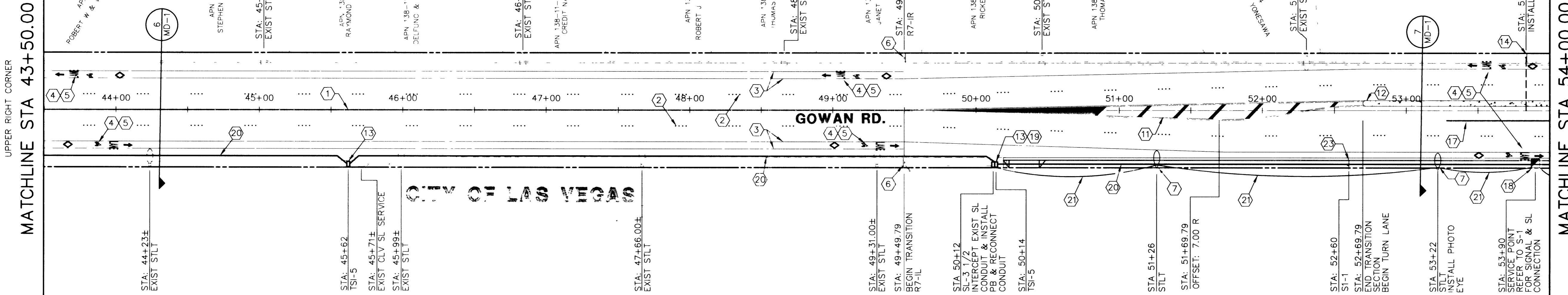

### PLAN - GOWAN ROAD

- TRAFFIC & STREET LIGHTING NOTES**
- 1 INSTALL TYPE 1 CENTERLINE IN ACCORDANCE WITH STANDARD DRAWING NO 244
  - 2 INSTALL TYPE 5 LANE LINE IN ACCORDANCE WITH STANDARD DRAWING NO 244A
  - 3 PAINT 6" SOLID WHITE LINE BIKE LANE IN ACCORDANCE WITH STANDARD DRAWING NO 244.2A
  - 4 TAPE PREFERENTIAL LANE SYMBOL IN CENTER OF BIKE LANE SIZE IN ACCORDANCE WITH FHA STANDARD ALPHABET FOR HIGHWAY SIGNS AND PAVEMENT MARKINGS
  - 5 TAPE DESIGNATED BICYCLE LANE SYMBOL IN CENTER OF BIKE LANE SIZE IN ACCORDANCE WITH FHA STANDARD ALPHABET FOR HIGHWAY SIGNS AND PAVEMENT MARKINGS
  - 6 INSTALL R7-IL, R7-IR "NO PARKING ANYTIME" SIGN SEE ABOVE PLAN FOR LEFT OR RIGHT SIGN DESIGNATION. SIGN TO BE POST MOUNTED UNLESS NOTED AS POLE MOUNT, APPLY INDUSTRIAL GRADE PAINT (SAFETY RED) TO CURB IN NO PARKING AREA
  - 7 INSTALL STREET LIGHT IN ACCORDANCE WITH UNIFORM STANDARD DRAWING NO. 313, 8" MAST ARM, WITH SAFETY BASE AND ADAPTER PLATE UNIFORM STANDARD NO.322, TYPE "H" FOUNDATION UNIFORM STANDARD DRAWING NO 404 208 AND 200W HIGH PRESSURE SODIUM LUMINAIRE
  - 8 INSTALL STREET LIGHT IN ACCORDANCE WITH UNIFORM STANDARD DRAWING NO. 313, 8" MAST ARM, WITH SAFETY BASE AND ADAPTER PLATE UNIFORM STANDARD NO.322, TYPE "H" FOUNDATION UNIFORM STANDARD DRAWING NO 404 208 AND 200W HIGH PRESSURE SODIUM LUMINAIRE
  - 9 INSTALL 10' LONG X 24" WIDE COLD POLYMER FILM CROSSWALK STRIPE (ALIGN STRIPING WITH LANE LINES AND MIDPOINT OF LANE LINES)

- 9A INSTALL 10' CROSS WALK PER USD NO. 254
- 10 INSTALL 24" COLD POLYMER FILM STOP BAR
- 11 INSTALL LANE DELINEATION IN TRANSITION SECTIONS IN ACCORDANCE WITH STANDARD DRAWING NO 245, LENGTH PER PLAN
- 12 INSTALL MEDIAN NOSE MARKINGS IN ACCORDANCE WITH STANDARD DRAWING NO 248 (W=3')
- 13 INSTALL NO. 5 PULLBOX IN ACCORDANCE WITH UNIFORM STANDARD DRAWING NO.404.120
- 14 INSTALL R2-1 SPEED LIMIT SIGN 24"x30" (25 MPH)
- 15 INSTALL TYPE 2 CENTERLINE IN ACCORDANCE W/ STANDARD DRAWING NO 244
- 16 INSTALL R1-1 STOP SIGN
- 16A INSTALL STREET NAME SIGN PER STANDARD DRAWING NO 249
- 17 INSTALL STANDARD PAVEMENT MARKERS FOR TURN LANE IN ACCORDANCE WITH STANDARD DRAWING NO 246
- 18 INSTALL SINGLE METER PADMOUNT SERVICE (200 A) IN ACCORDANCE WITH UNIFORM STANDARD DRAWING NO. 404.1412 (2 DWGS.)
- 19 INSTALL NO. 3-1/2 PULL BOX IN ACCORDANCE WITH UNIFORM STANDARD DRAWING NO. 404.110

- 20 INSTALL 2" INTERCONNECT CONDUIT IN ACCORDANCE WITH SPECIFICATION 623G.02.01 (WITH 12 PAIR #22 AWG WIRES TYP)
- 21 INSTALL 1-1/4" STREET LIGHT CONDUIT, UNLESS OTHERWISE SHOWN, IN ACCORDANCE WITH SPECIFICATION 623G.02.01 (WITH 2-#4, 1-#8 WIRES TYP)
- 22 **STREET LIGHT REMOVAL:**  
CHIP FOUNDATION DOWN 18" BELOW FINISH GRADE. CUT ANCHOR RODS FLUSH AND RECONNECT WIRE  
SAWCUT SIDEWALK AT THE EXISTING JOINTS, REMOVE AND REPLACE EXISTING SIDEWALK IN FULL SECTION  
ALL EXISTING STREET LIGHTS REMOVED WHICH ARE NOT ACCEPTABLE TO BE REUSED WITHIN THE PROJECT SHALL BE RETURNED TO THE CITY OF LAS VEGAS YARD AT 3104 E. BONANZA ROAD (CALL 229-6331 BEFORE RETURNING)  
AFTER STREET LIGHT BASE REMOVAL CONNECT EXISTING STREET LIGHT CONDUIT TOGETHER PAST BASE FOR FUTURE USE, (INSTALL 3 1/2 PULLBOX AS NEEDED TO REPUW WIRE)
- 23 INSTALL S1-1 SCHOOL ADVANCE SIGN
- 24 INSTALL S2-1 SCHOOL CROSSING SIGN
- 25 MODIFY EXISTING STREET LIGHT FOUNDATION IN ACCORDANCE WITH UNIFORM STANDARD DWG NO 325
- 26 INSTALL MODIFIED CRASH CAP IN ACCORDANCE WITH DETAIL 7 SHEET MD-2

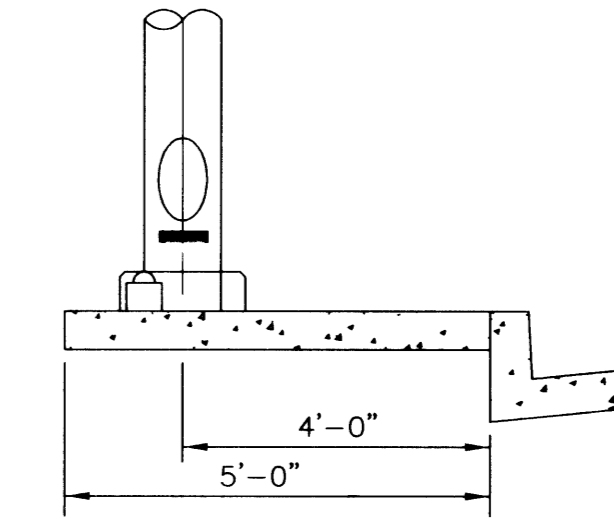

**STREET LIGHT NOTE:**  
ALL HAND HOLE COVERS MUST BE INSTALLED, POLE CAPS POURED, & PULL BOX LIDS BOLTED DOWN PRIOR TO ENERGIZING CIRCUIT. ALL WIRE MUST HAVE THW INSULATION

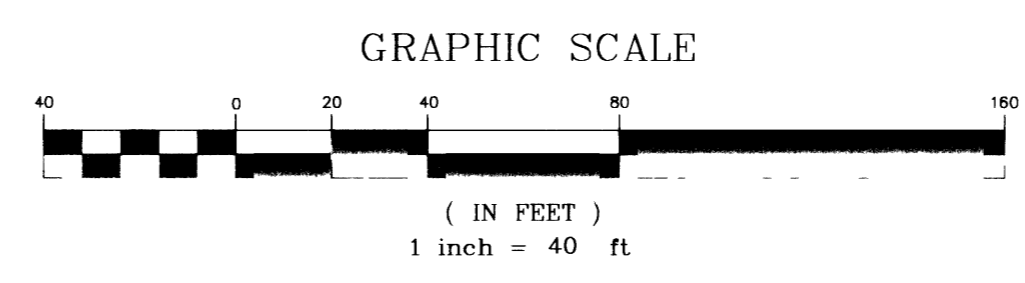

### PLAN - GOWAN ROAD

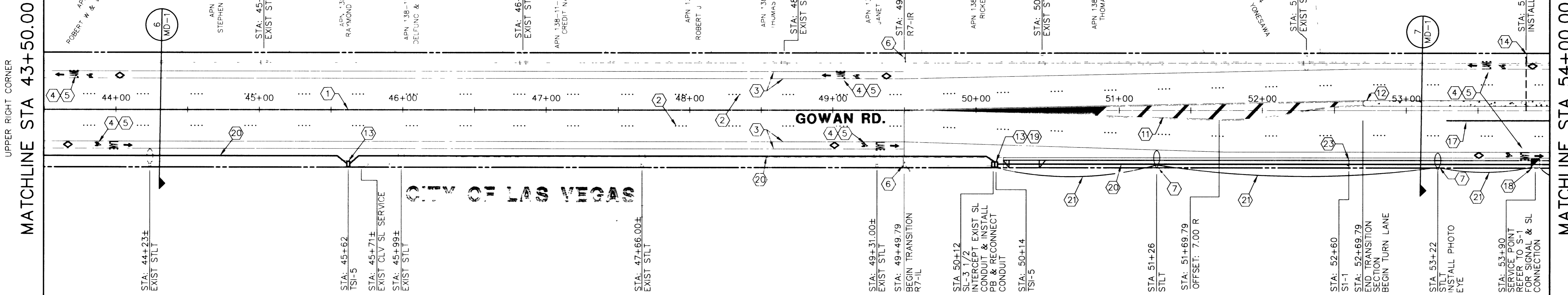

### PLAN - GOWAN ROAD

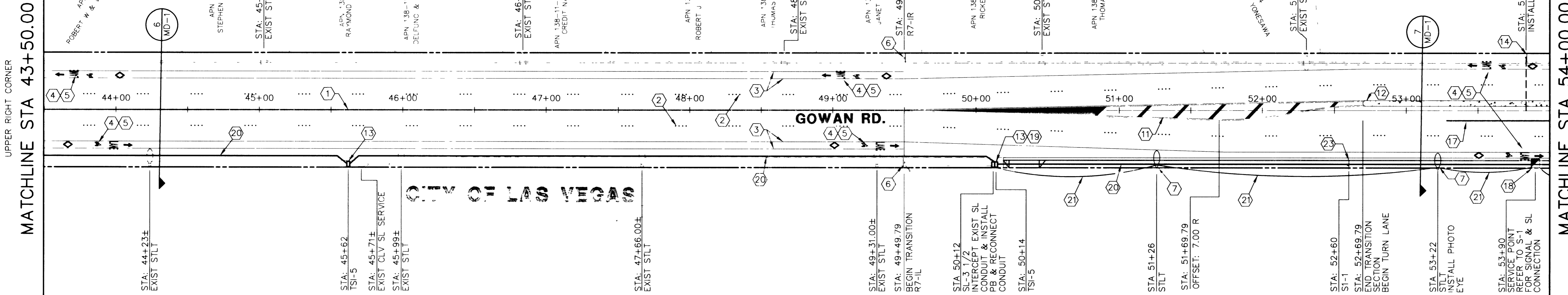

UPPER RIGHT CORNER

SEE SHEET T-1

MATCHLINE STA 43+50.00

MATCHLINE STA 32+00.00

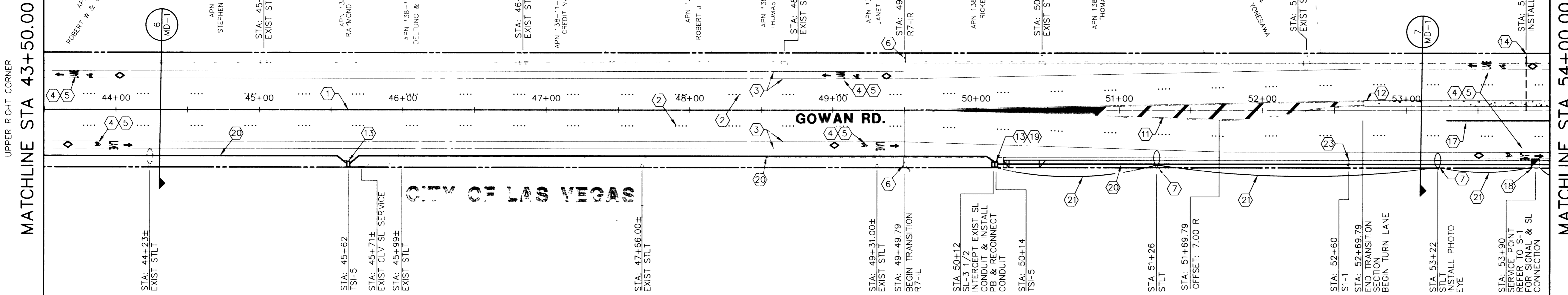

### PLAN - GOWAN ROAD

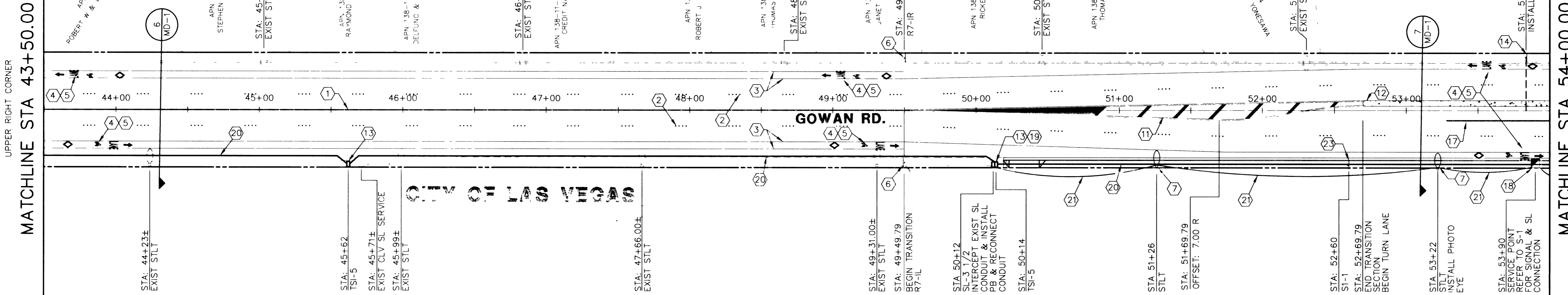

UPPER RIGHT CORNER

SEE SHEET T-1

MATCHLINE STA 43+50.00

MATCHLINE STA 32+00.00

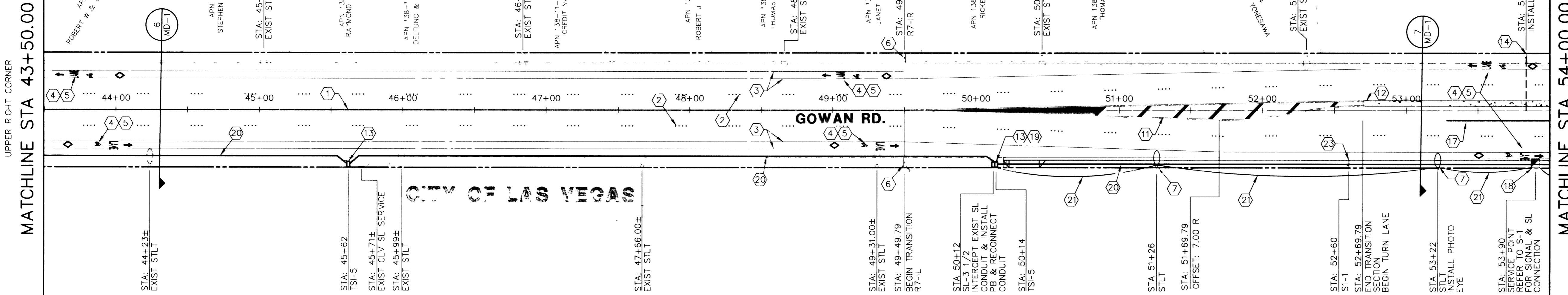

### PLAN - GOWAN ROAD

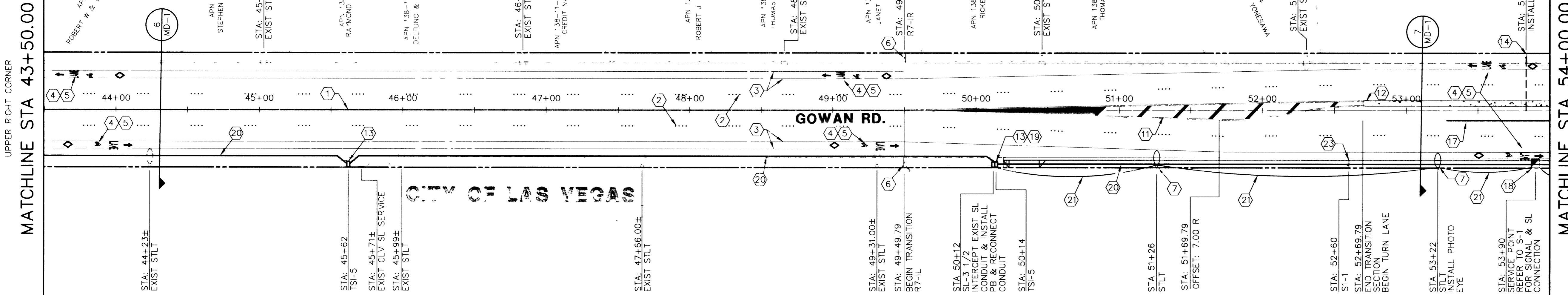

UPPER RIGHT CORNER

SEE SHEET T-1

MATCHLINE STA 43+50.00

MATCHLINE STA 32+00.00

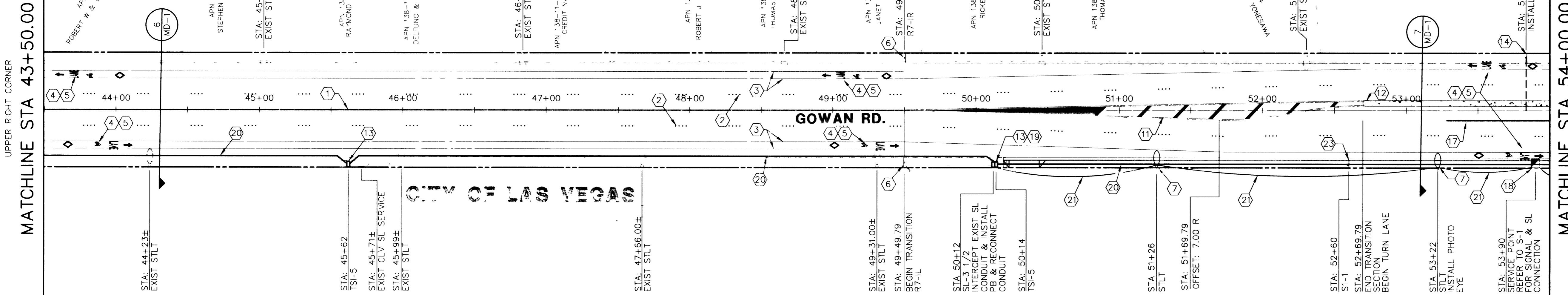

### PLAN - GOWAN ROAD

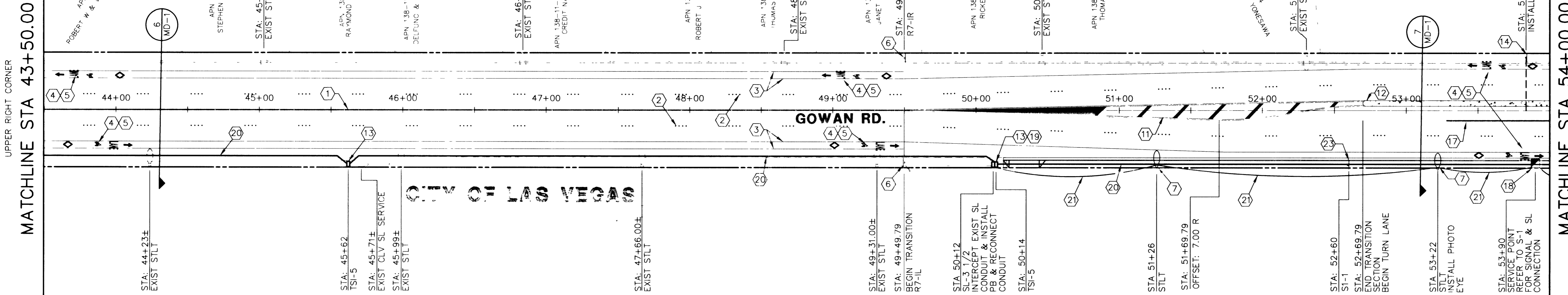

UPPER RIGHT CORNER

SEE SHEET T-1

MATCHLINE STA 43+50.00

MATCHLINE STA 32+00.00

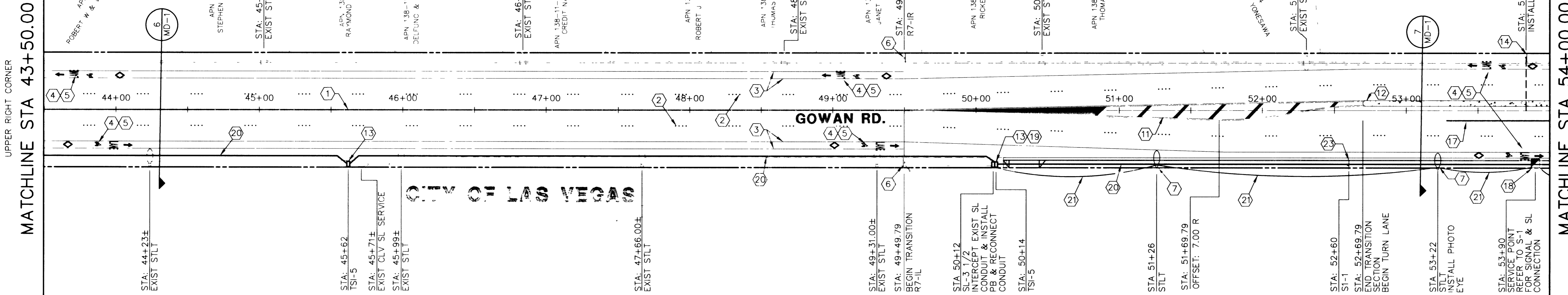

### PLAN - GOWAN ROAD

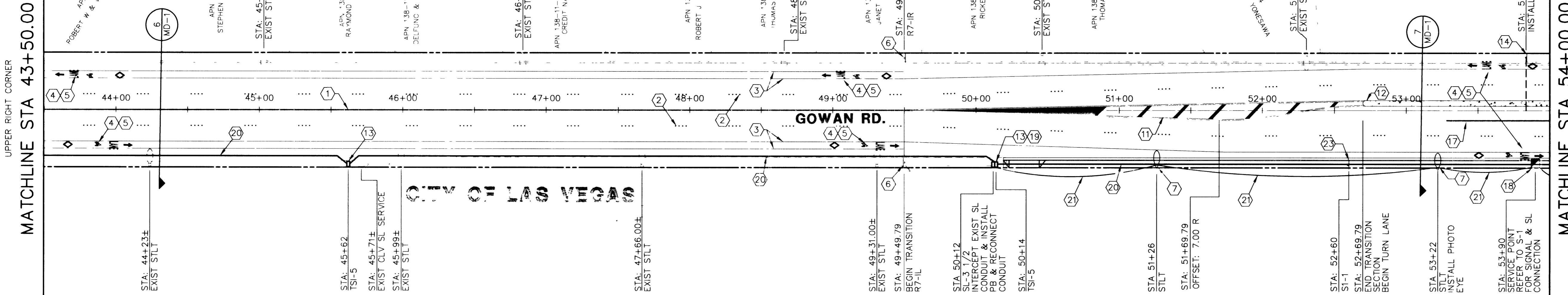

UPPER RIGHT CORNER

SEE SHEET T-1

MATCHLINE STA 43+50.00

MATCHLINE STA 32+00.00

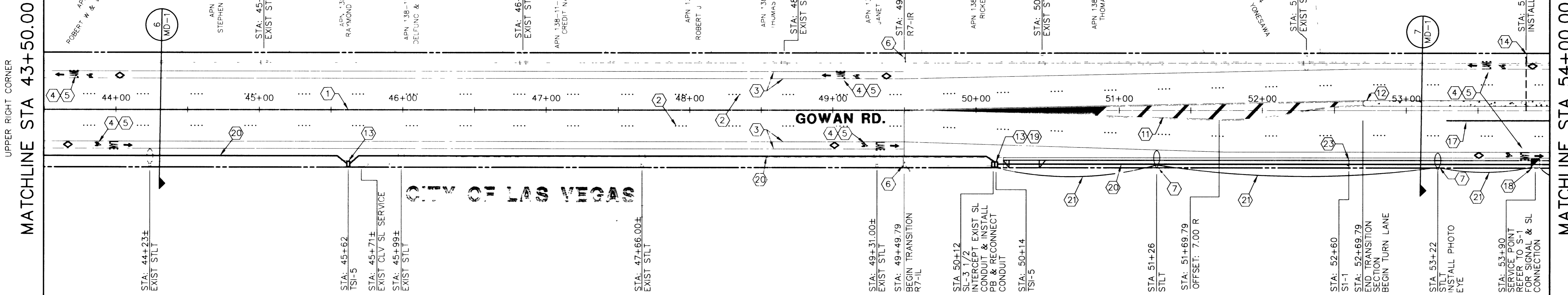

### PLAN - GOWAN ROAD

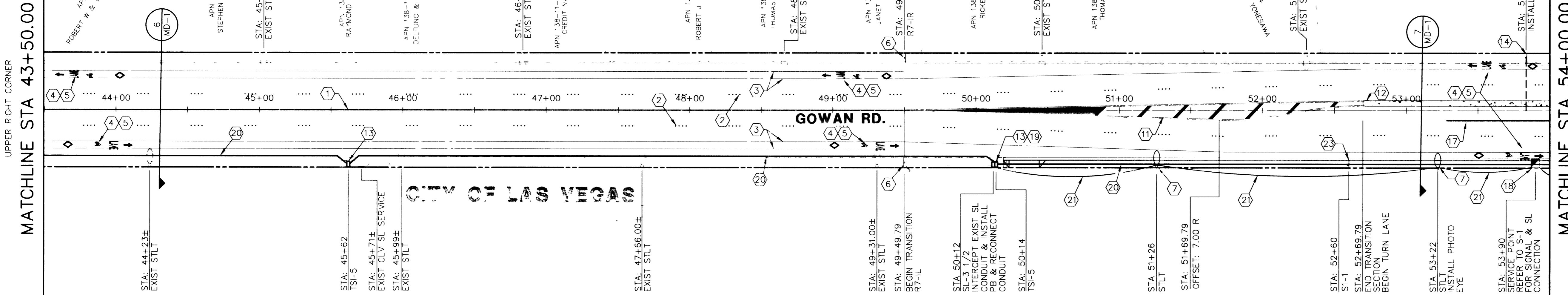

UPPER RIGHT CORNER

SEE SHEET T-1

MATCHLINE STA 43+50.00

MATCHLINE STA 32+00.00

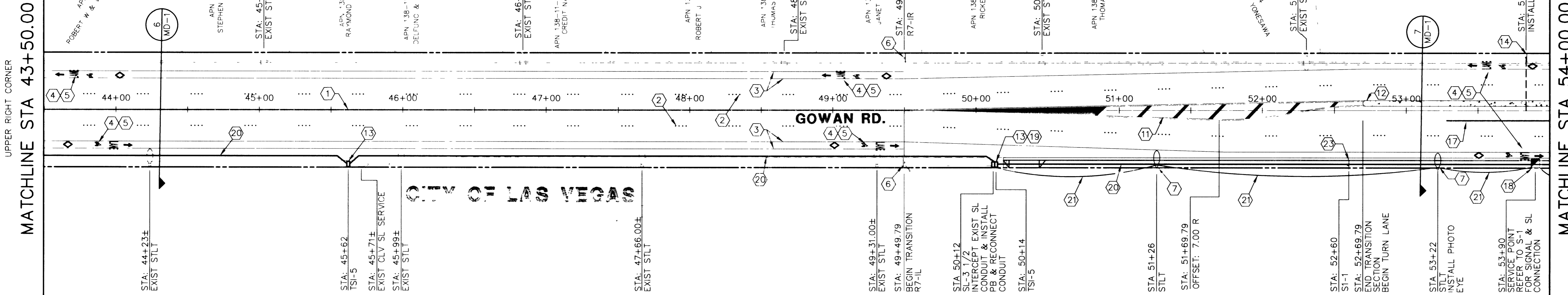

### PLAN - GOWAN ROAD

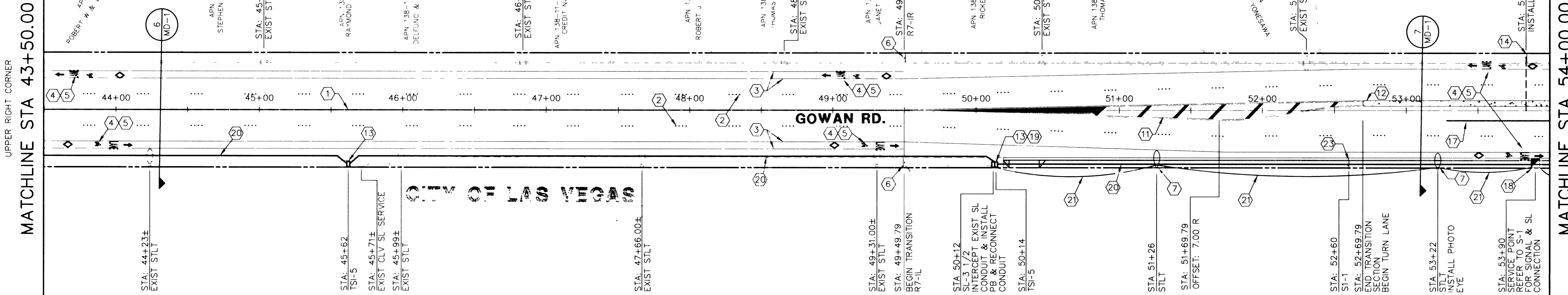

UPPER RIGHT CORNER

SEE SHEET T-1

MATCHLINE STA 43+50.00

MATCHLINE STA 32+00.00

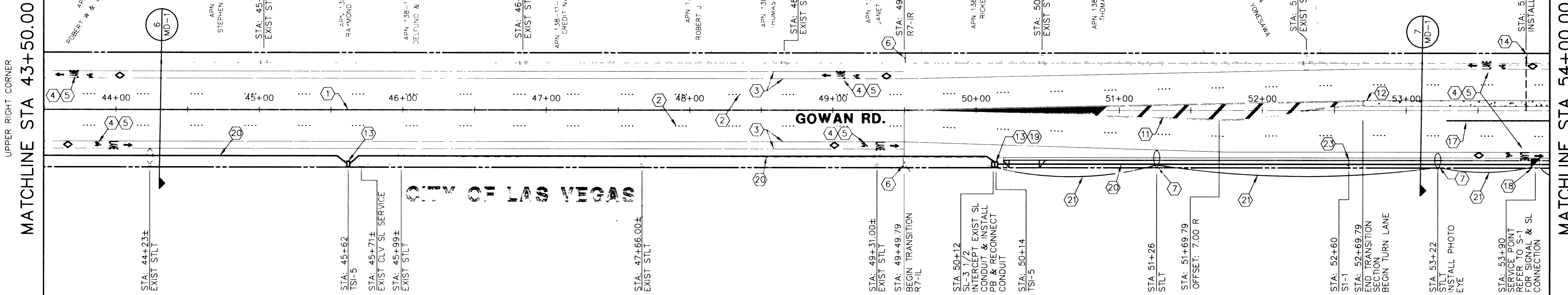

### PLAN - GOWAN ROAD

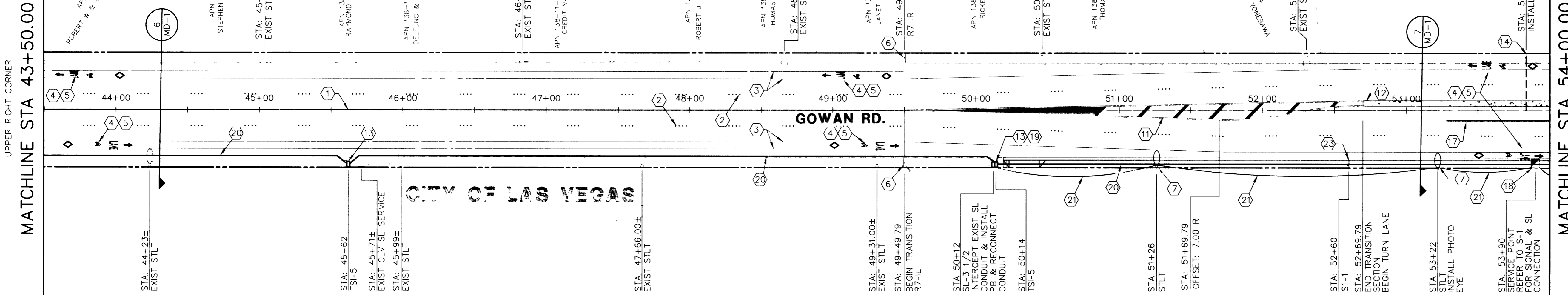

UPPER RIGHT CORNER

SEE SHEET T-1

MATCHLINE STA 43+50.00

MATCHLINE STA 32+00.00

