

**NOTE:**  
CONTRACTOR TO VERIFY ALL ELECTRICAL & TELEPHONE UTILITIES COMPANIES PRIOR TO TRENCHING ALONG FENCE LINE.

**NOTE:**  
CONTRACTOR TO PROVIDE 2" P.V.C. SLEEVE ACROSS ROAD. W/WIRES FOR 3 IRRIG. VALVES AND COLLECTED TO EXISTING CONTROL VALVE BOX. ALL MALE VALVES, GUYE COUPLERS, CAPS, COLLECTIONS, ETC.

**NOTE**

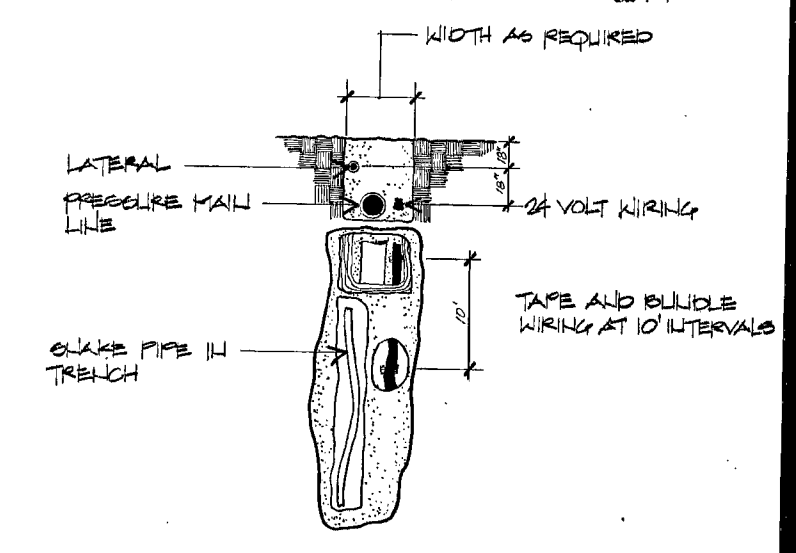
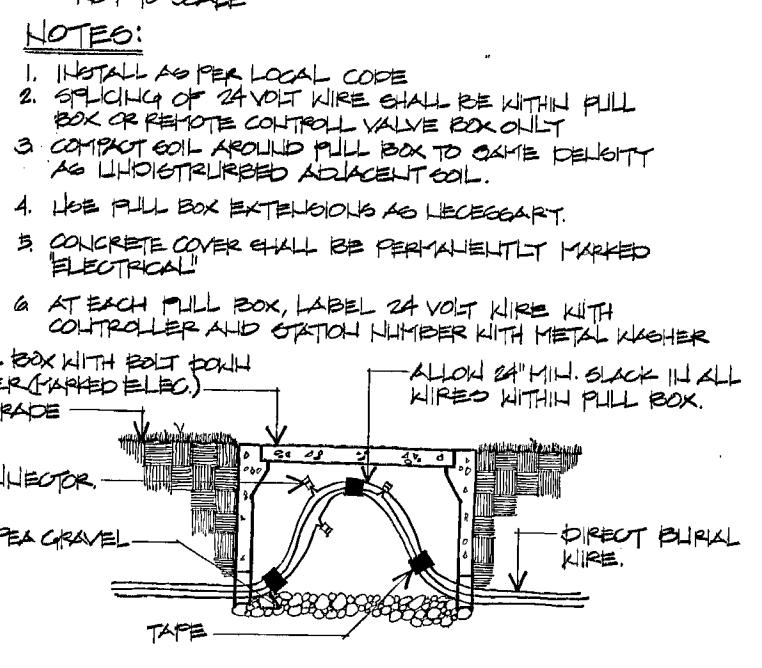
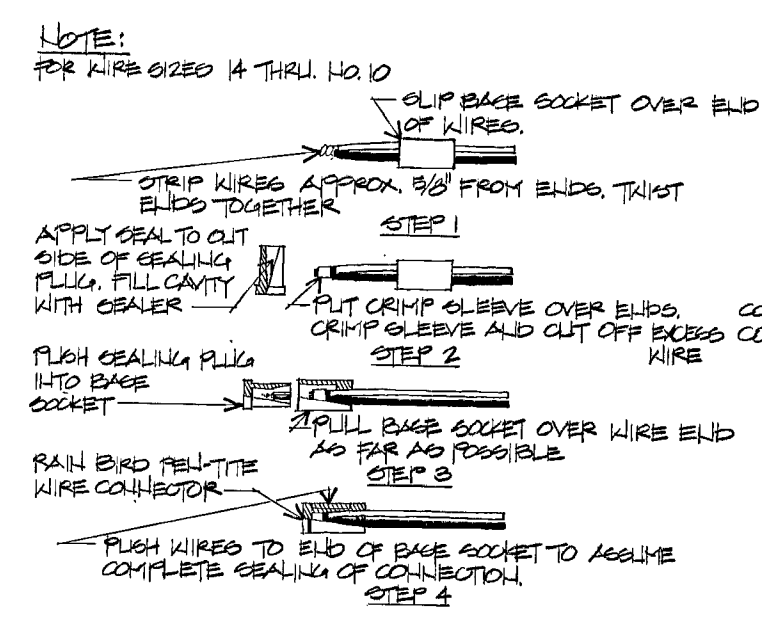
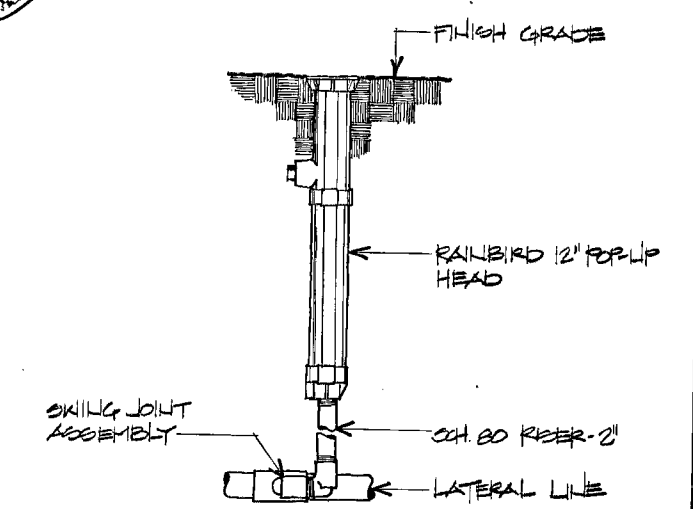
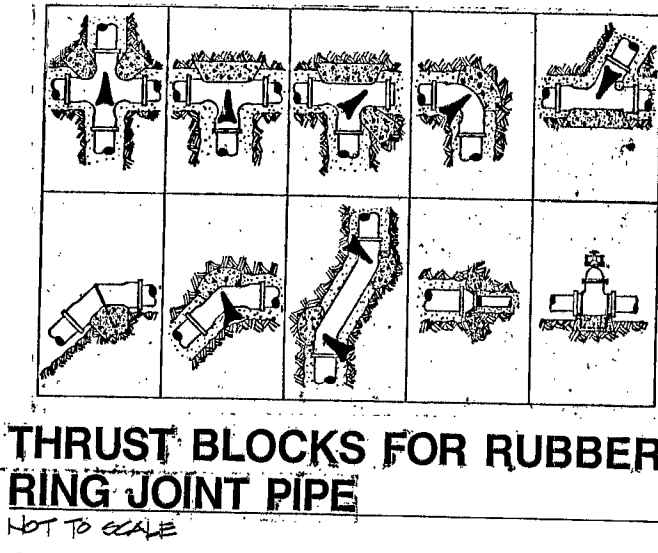
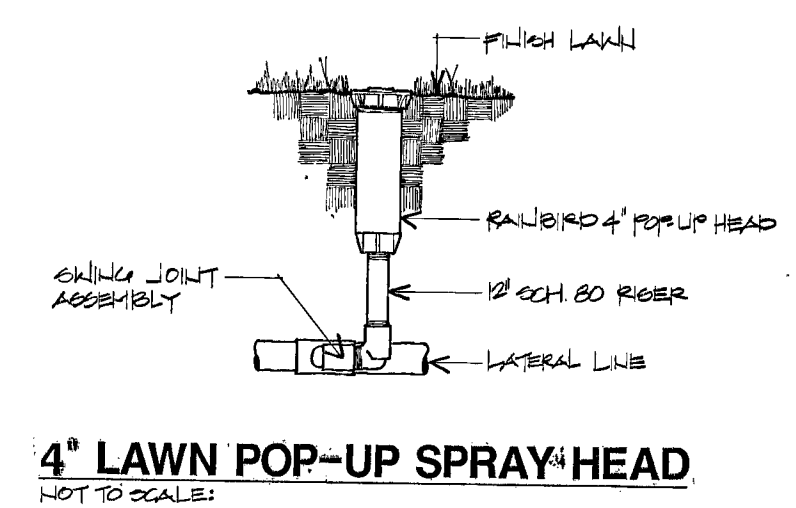

date  
revisions

FILE NO. 4/25/87  
PROJ. NO. 82-00-0015  
UNIT COORD. JAY 4/87  
ASST. ADM. P&D  
ASST. ADM. O&M  
CITY ADMIN.

**FLOYD LAMB STATE PARK**  
**IRRIGATION PLAN AND DETAILS**

DEPARTMENT OF CONSERVATION and NATURAL RESOURCES  
**NEVADA DIVISION OF STATE PARKS**  
CAPITOL COMPLEX CARSON CITY NEVADA 89710

