

16 NOT USED

12 NOT USED

8 NOT USED

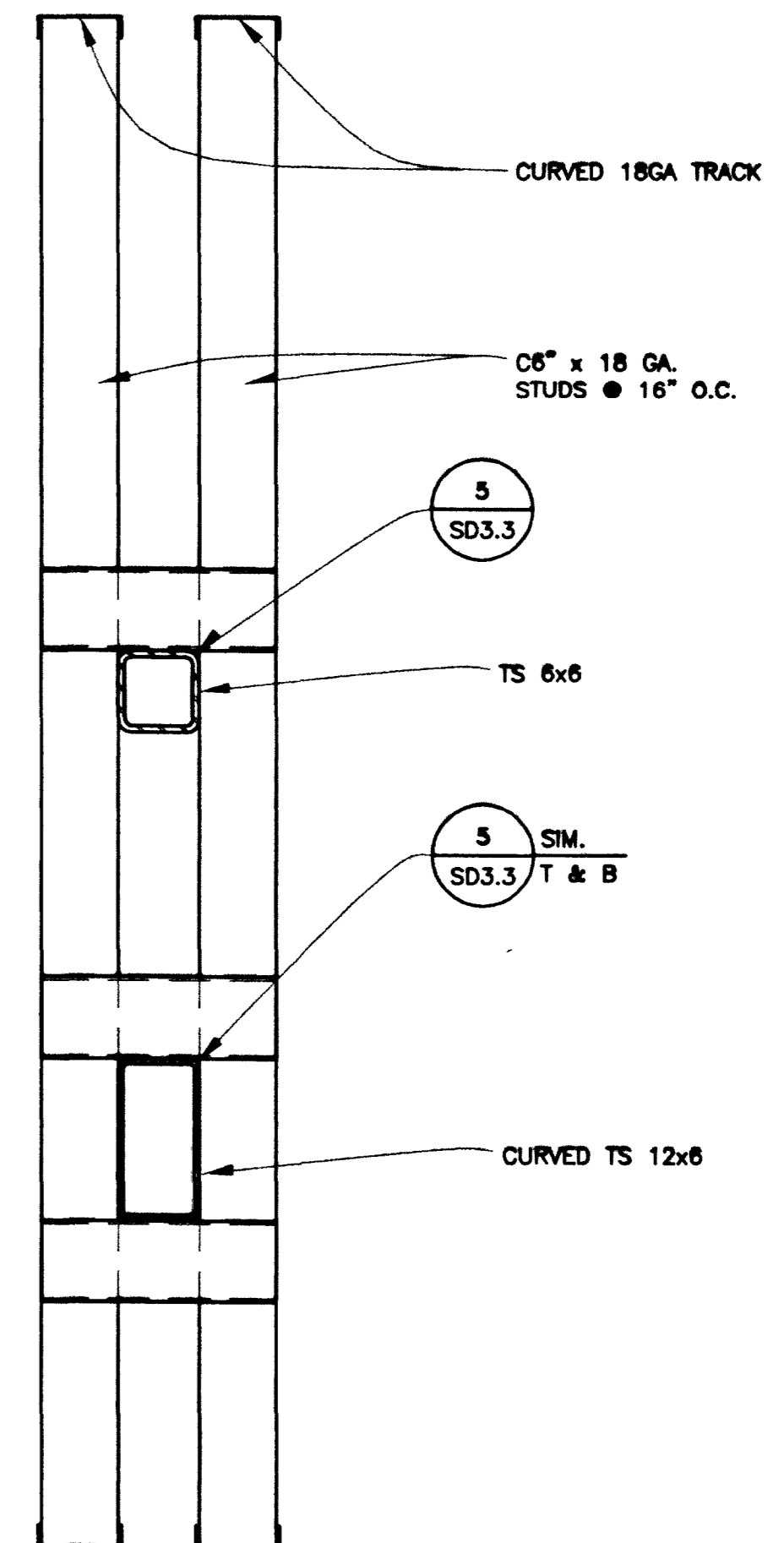
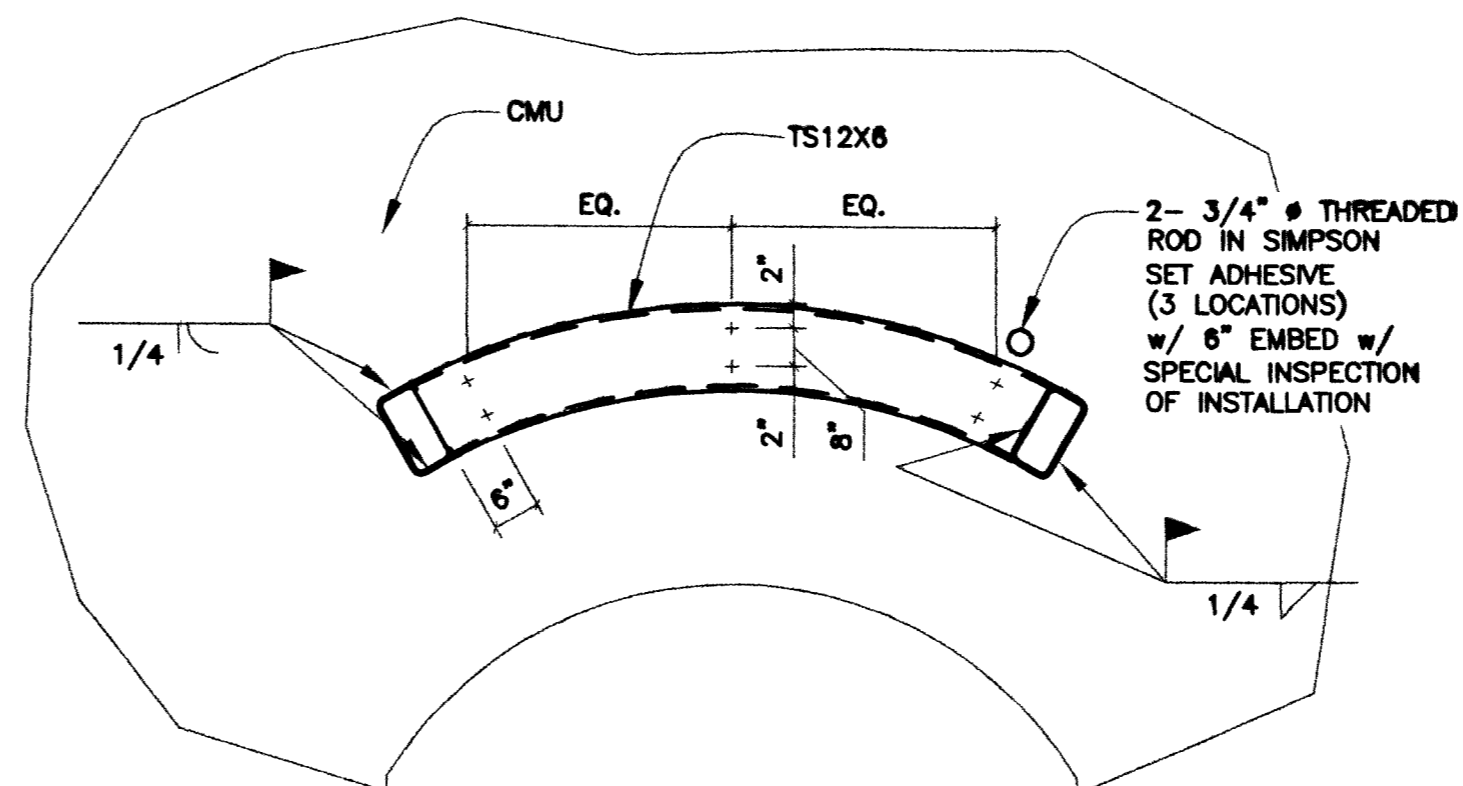
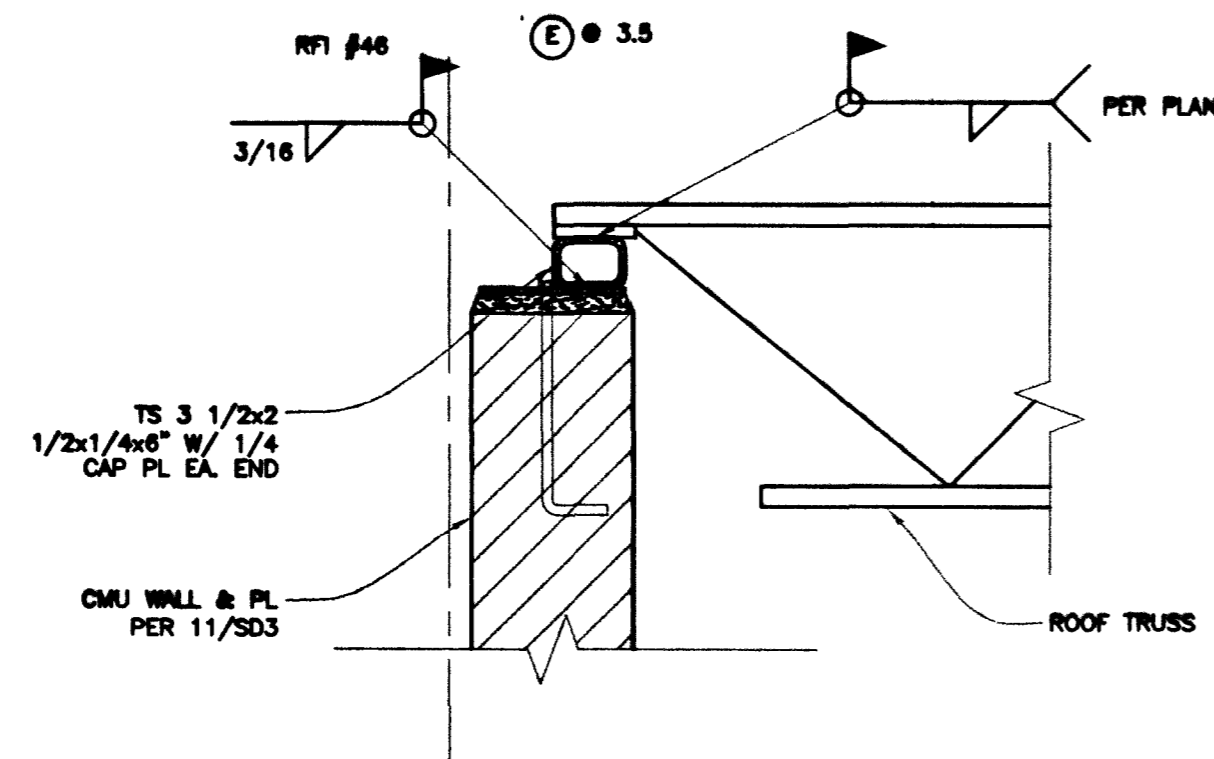

15 NOT USED

11 ROOF TRUSS BRG. DETAIL E-3.5

7 NOT USED

3 SECTION
1 1/2\"/>

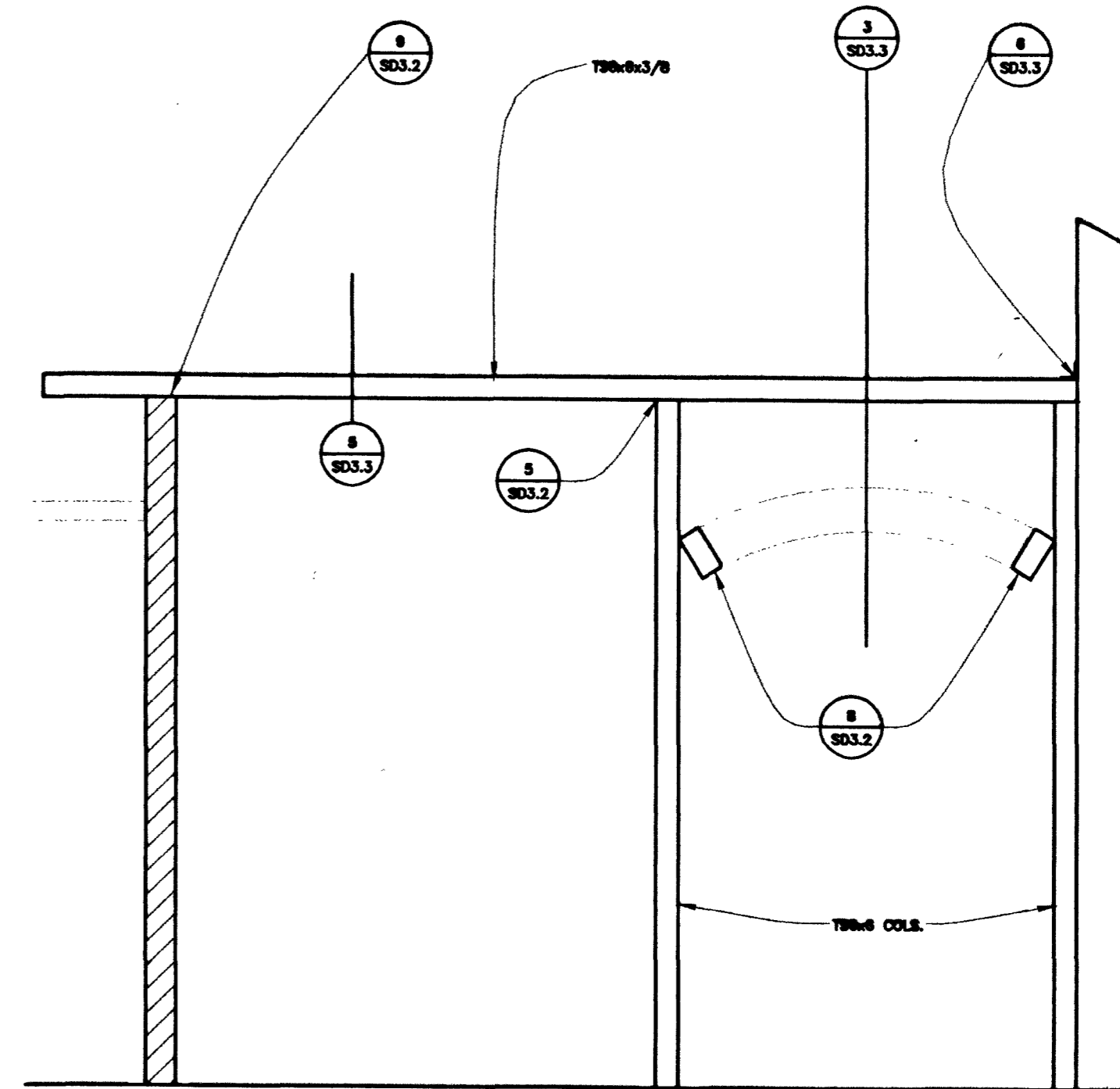
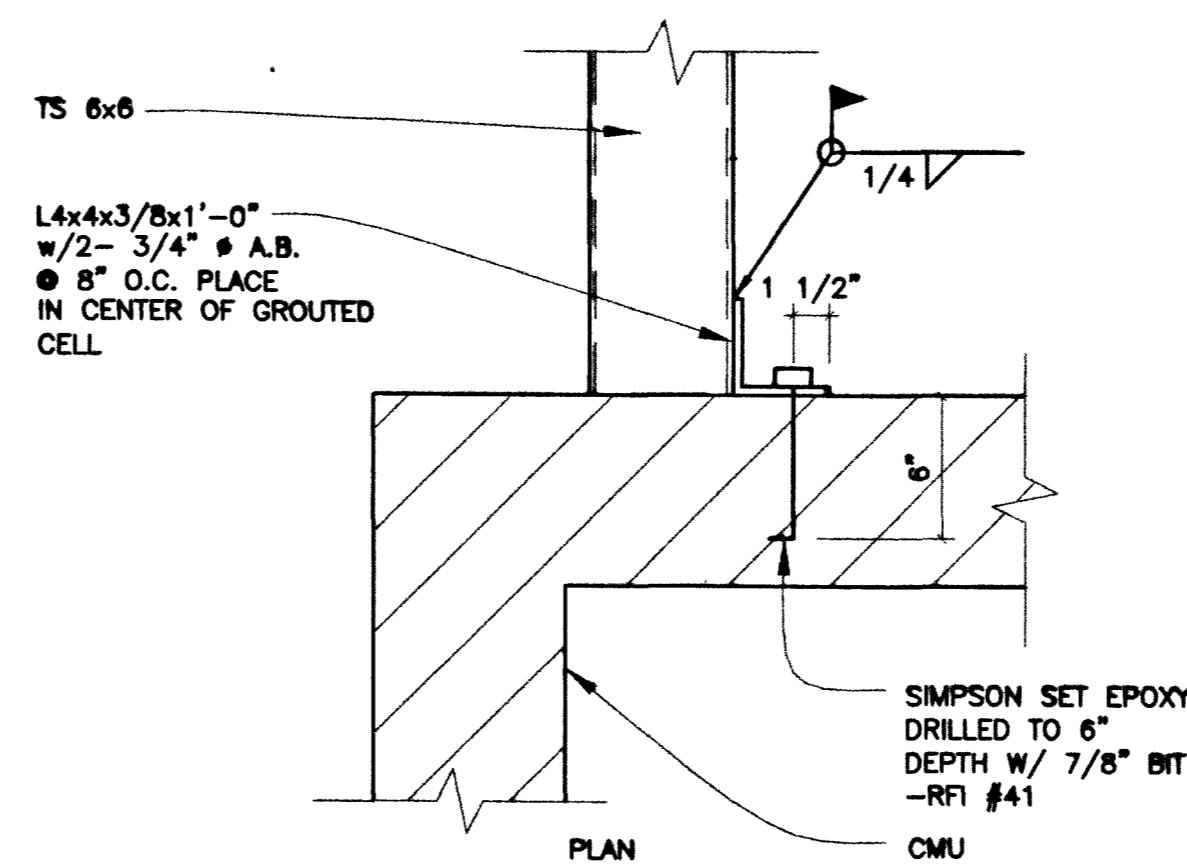
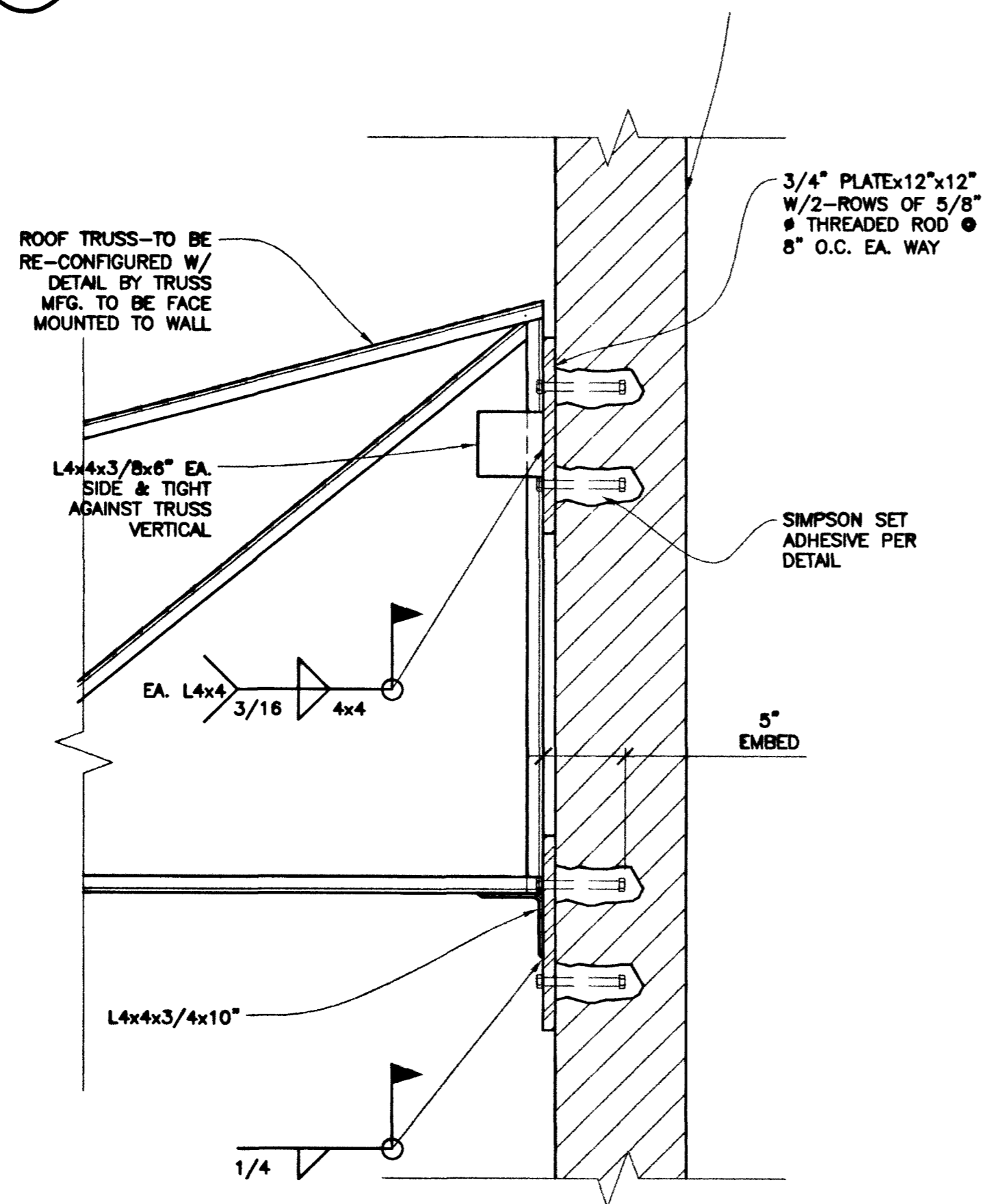

14 NOT USED

6 SECTION
1 1/2\"/>

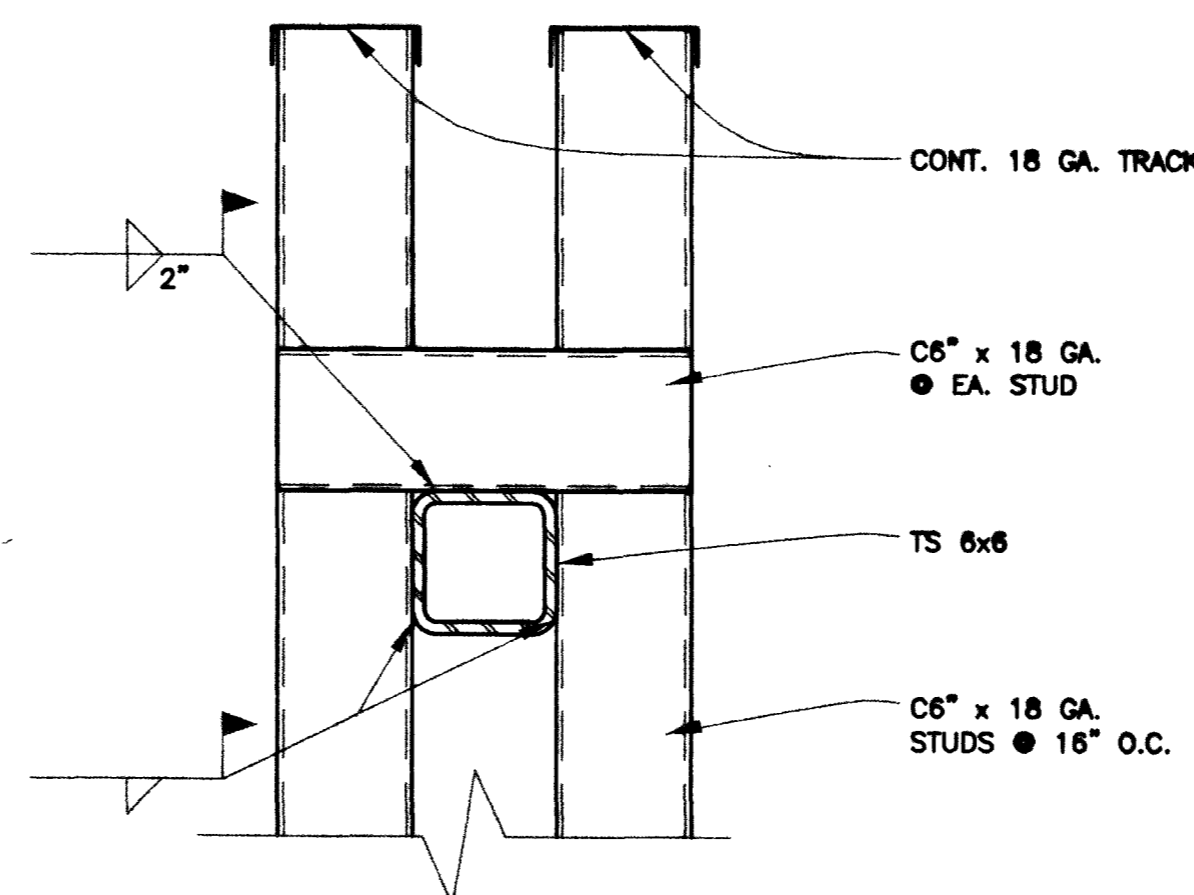

13 NOT USED 57296

9 DETAIL C

5 SECTION
1 1/2\"/>

1 SECTION
1\"/>



REVISIONS

NO.	DATE	DESCRIPTION
1		

B-6-01 BLDG DEPT RESUBMITAL

DEC INC.

2900 SO. RANCHO RD.
LAS VEGAS, NEVADA 89102
(702) 871-5154

CITY OF LAS VEGAS, NEVADA
FIRE STATION #44
FRAMING DETAILS

DEPARTMENT OF PUBLIC WORKS
ARCHITECTURAL SERVICES

400 EAST STEWART AVENUE
LAS VEGAS, NEVADA 89101
PHONE: (702) 225-6338
FAX: (702) 382-3223
TDD: (702) 388-9106

DESIGN ENGINEERING CONSULTANTS

DESIGNER	JUB
FILE	
DATE	7/1/06
SCALE	AS NOTED
PROJECT	630.97
SHEET NO.	740F106

SD3.3

THE CITY OF LAS VEGAS, NEVADA, IS THE PROPRIETOR OF THIS PROJECT. THE CITY OF LAS VEGAS, NEVADA, IS NOT RESPONSIBLE FOR THE DESIGN OR CONSTRUCTION OF THIS PROJECT. THE CITY OF LAS VEGAS, NEVADA, IS NOT RESPONSIBLE FOR THE DESIGN OR CONSTRUCTION OF THIS PROJECT. THE CITY OF LAS VEGAS, NEVADA, IS NOT RESPONSIBLE FOR THE DESIGN OR CONSTRUCTION OF THIS PROJECT.