

PLAN

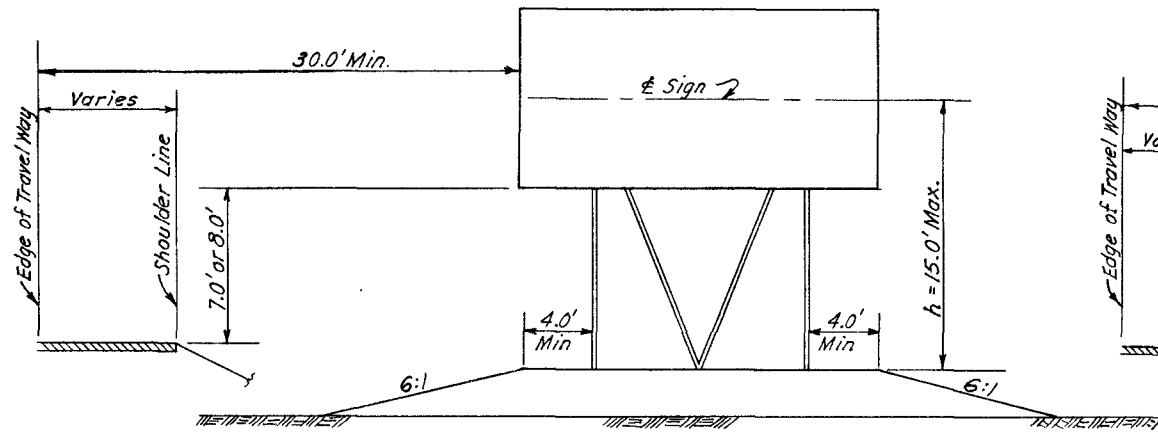

LEVEL

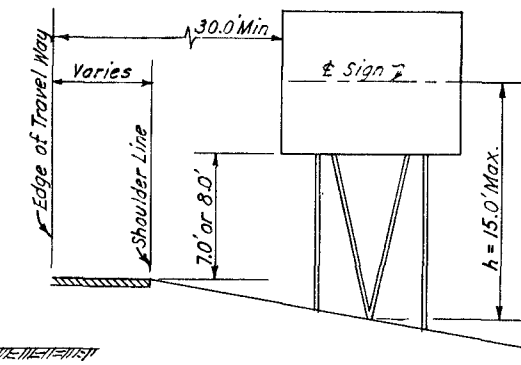

BRACED

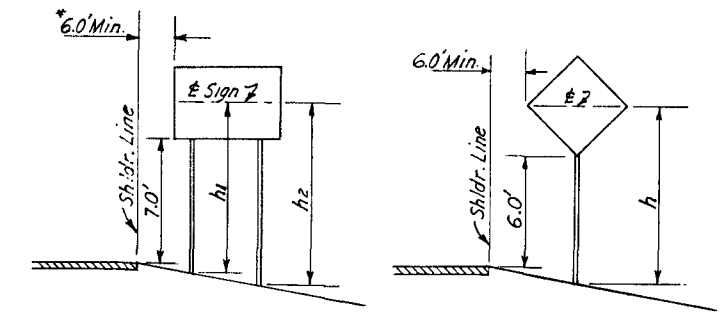

UNBRACED
*2.0' Min. when sign placed in gore.

SINGLE

EMBANKMENT
(WITHOUT SIGN ISLAND)

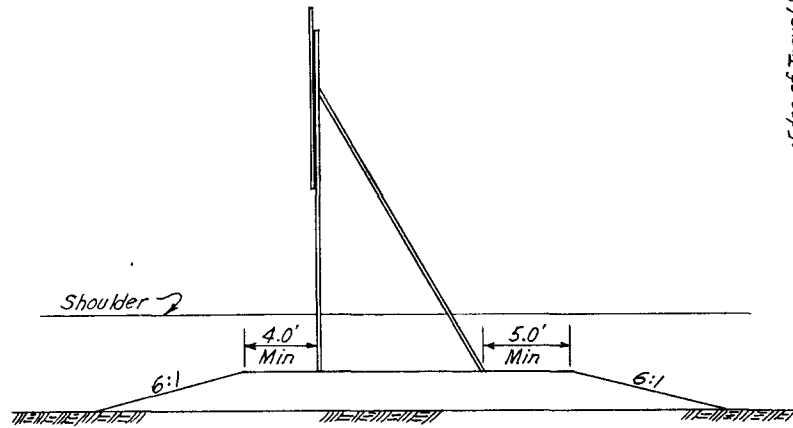

ELEVATION

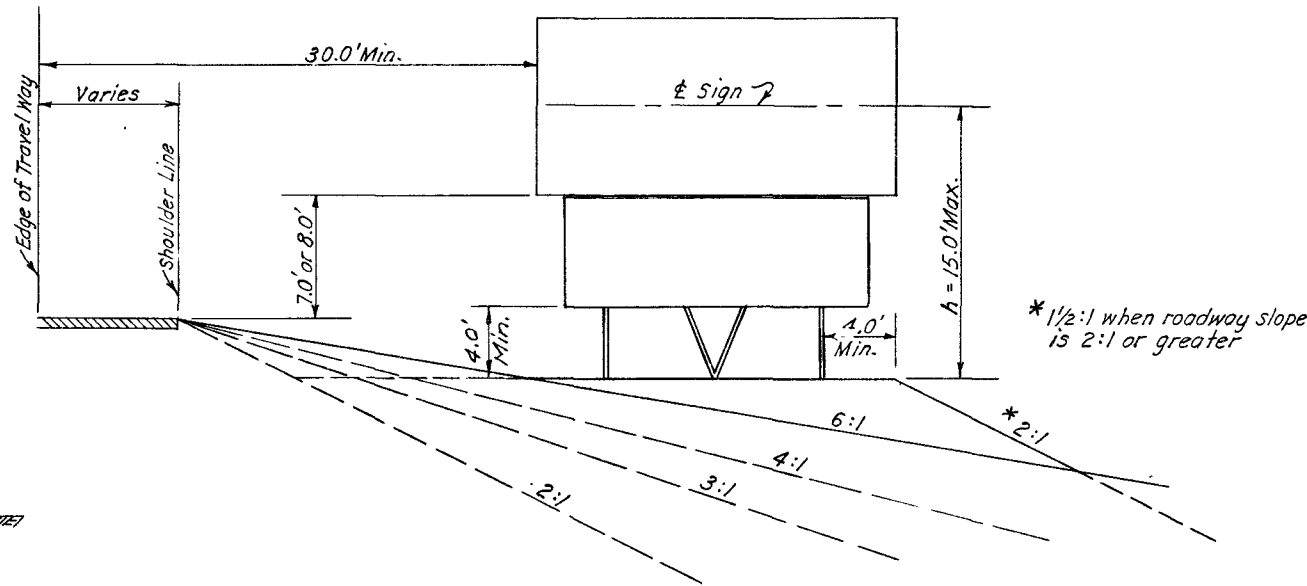

EMBANKMENT

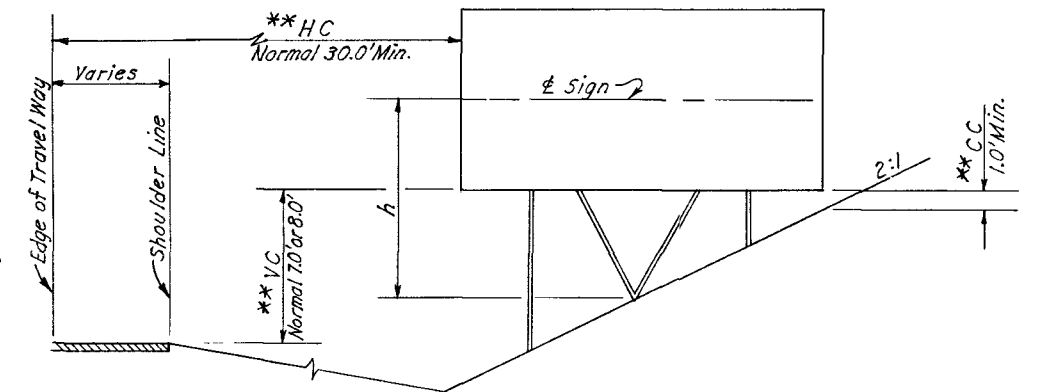

****NOTE:**
If CC is less than 1.0' Minimum
(1) Raise sign until CC = 1.0' or VC = 10.0' Max. for single sign, VC = 11.0' Max for double sign, or h = 15.0' Max.
(2) Maintain VC = 10.0' or 11.0' and move sign toward shoulder until CC = 1.0', HC = 6.0' Min, or h = 15.0' Max.
(3) Special consideration is necessary if given limits are exceeded.

EXCAVATION

SIGN ISLANDS

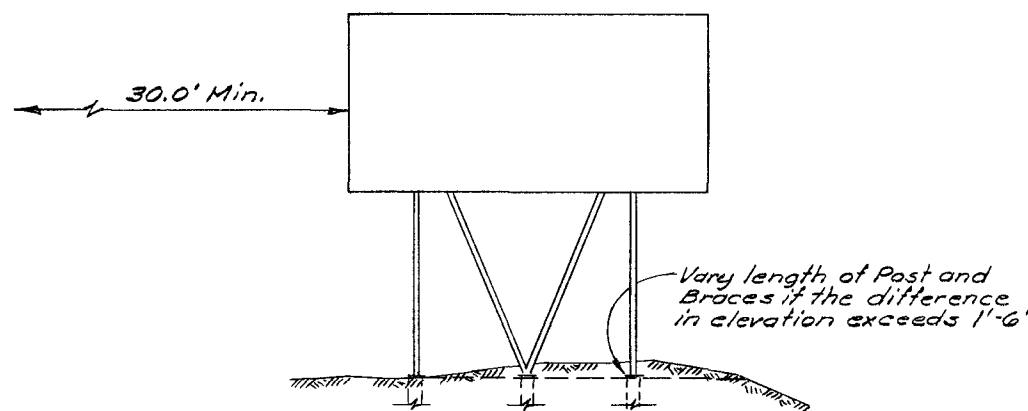

When the sign location is in original ground, the area between the supports and the braces should be leveled to maintain identical post lengths. (No Direct Payment For The Leveling)

GENERAL NOTES

1. Sign Island required only when h exceeds 15.0' without island. Island to be compacted to 95%.
2. Footing and Sign Details shown on Sheets No 1, 2 and 3.
3. 30'-0" minimum distance from edge of travel way to edge of sign panel may be reduced to 16'-0" minimum in areas where guard rail is to be installed.

168 107V3833

STATE OF NEVADA
DEPARTMENT OF HIGHWAYS

**STANDARD
GROUND MOUNTED
SIGN SUPPORTS**

57020 59068