

H	"Y" BARS
2'-0"	#4 @ 48"
2'-8"	#4 @ 48"
3'-4"	#4 @ 48"
4'-0"	#5 @ 16"

LOT 151 AND 152 RETAINING WALL DETAIL AND SCHEDULE

SCALE: 1/2" = 1'-0"

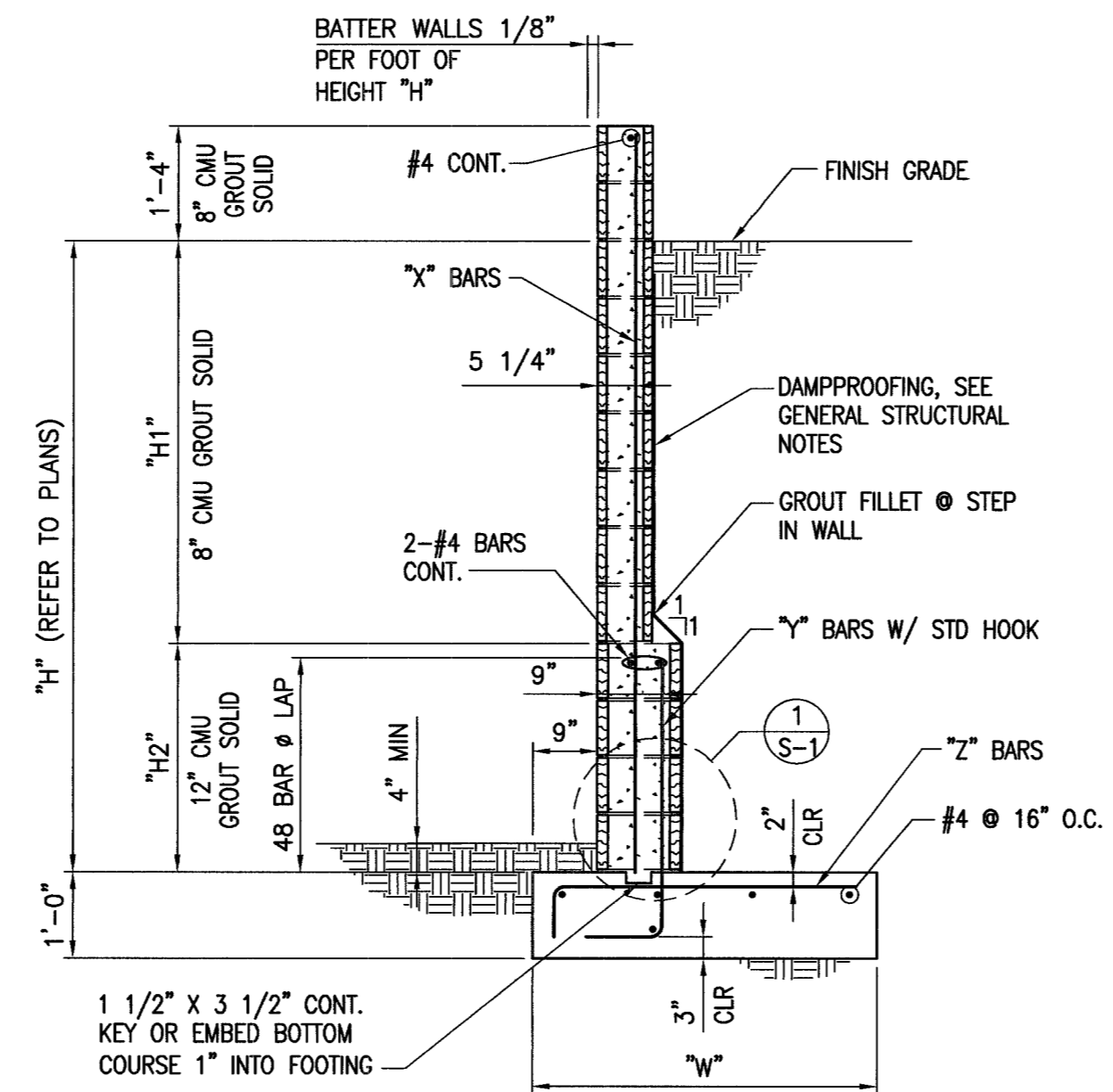

DIMENSIONS				"X" BARS	"Y" BARS	"Z" BARS
H	H1	H2	W	BARS	BARS	BARS
2'-0"	2'-0"	-	2'-0"	#4 @ 48"	#4 @ 48"	#4 @ 24"
2'-8"	2'-8"	-	2'-0"	#4 @ 48"	#4 @ 48"	#4 @ 24"
3'-4"	3'-4"	-	2'-3"	#4 @ 48"	#5 @ 48"	#4 @ 24"
4'-0"	4'-0"	-	2'-3"	#4 @ 48"	#5 @ 24"	#4 @ 24"
4'-8"	4'-8"	-	2'-9"	#4 @ 48"	#5 @ 24"	#4 @ 24"
5'-4"	5'-4"	-	3'-0"	#4 @ 48"	#5 @ 16"	#4 @ 24"
6'-0"	3'-4"	2'-8"	3'-6"	#5 @ 48"	#5 @ 24"	#4 @ 24"
6'-8"	4'-0"	2'-8"	3'-9"	#5 @ 32"	#5 @ 16"	#4 @ 16"
7'-4"	4'-8"	2'-8"	4'-0"	#5 @ 24"	#5 @ 16"	#4 @ 16"

* FOR THIS HEIGHT WALL THE "X" BARS MAY BE ELIMINATED BY EXTENDING THE "Y" BARS TO THE TOP OF THE WALL.

** WHEN "H2" DOES NOT EXIST, LOCATE THE "Y" BARS IN THE SAME POSITION AS THE "X" BARS. EXTEND THE "Y" BARS INTO THE MASONRY WALL 2'-0" MINIMUM FOR A #4 BAR AND 2'-6" MINIMUM FOR A #5 BAR. WHEN "H" IS LESS THAN 2'-0" CENTER "Y" BARS IN CENTER OF WALL.

RETAINING WALL W/WATER SURCHARGE DETAIL AND SCHEDULE

SCALE: 1/2" = 1'-0"

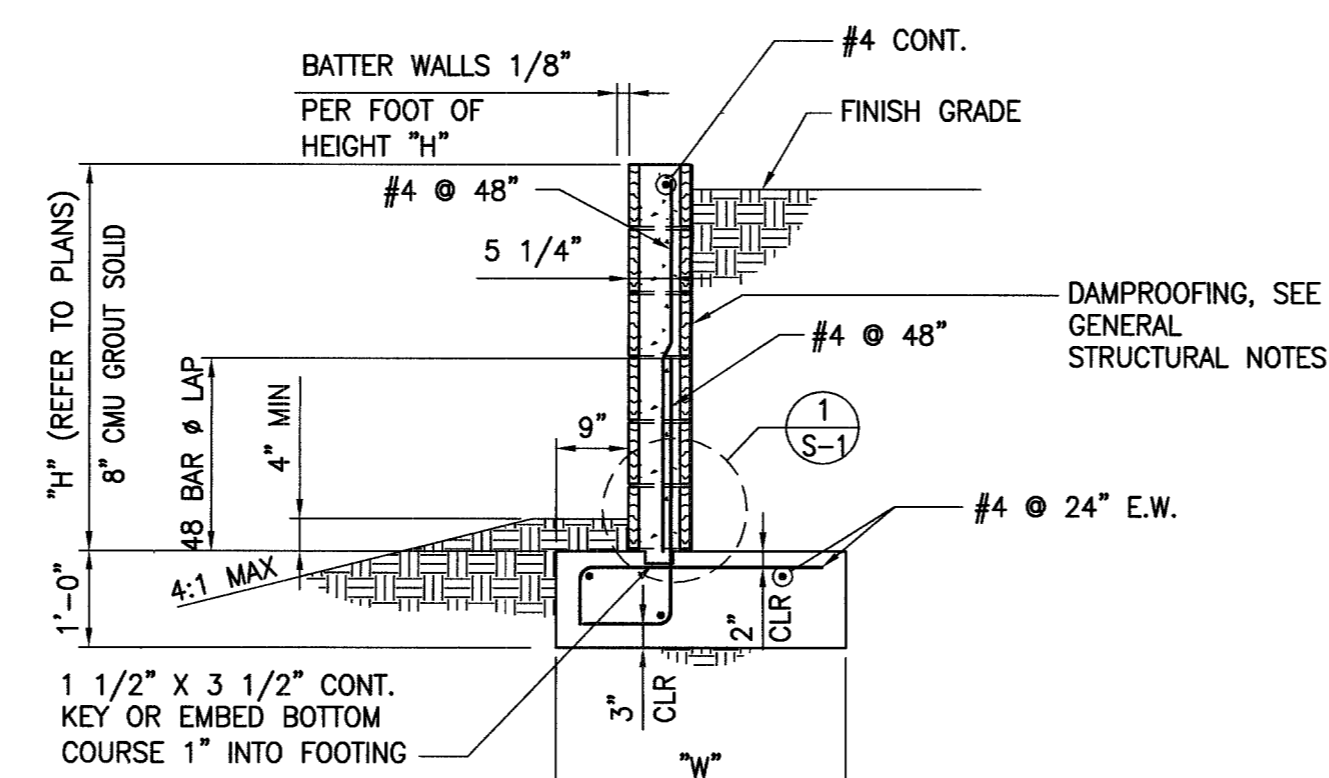

DIMENSIONS	
H	W
2'-0"	2'-0"
2'-8"	2'-3"
3'-4"	2'-6"
4'-0"	3'-0"

RETAINING WALL DETAIL AND SCHEDULE

SCALE: 1/2" = 1'-0"

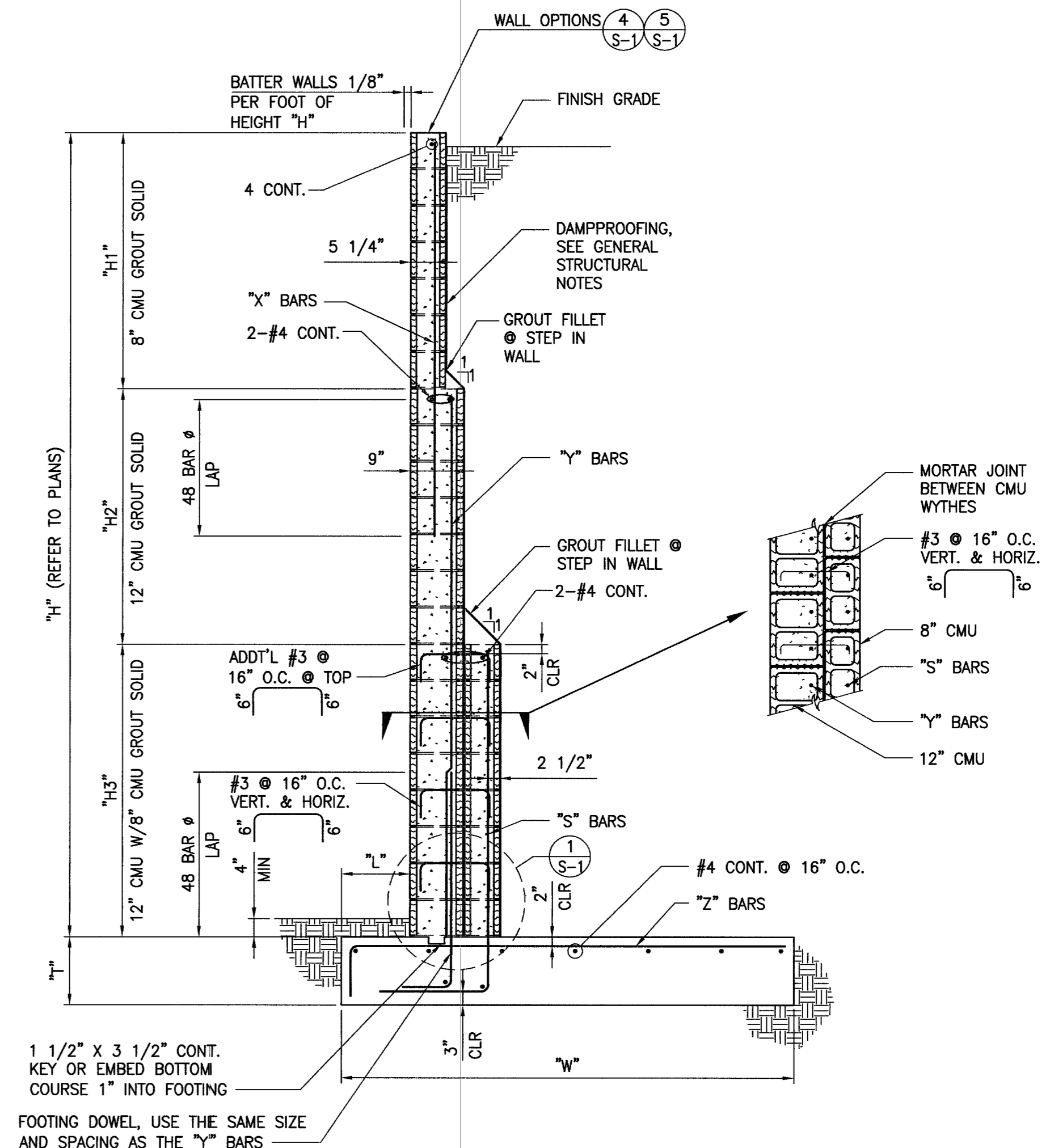

DIMENSIONS							"X" BARS	"Y" BARS	"S" BARS	"Z" BARS
H	H1	H2	H3	W	T	L	BARS	BARS	BARS	BARS
2'-0"	2'-0"	-	-	2'-0"	12"	9"	#4 @ 48"	#4 @ 48"	-	#4 @ 24"
2'-8"	2'-8"	-	-	2'-0"	12"	9"	#4 @ 48"	#4 @ 48"	-	#4 @ 24"
3'-4"	3'-4"	-	-	2'-0"	12"	9"	#4 @ 48"	#5 @ 48"	-	#4 @ 24"
4'-0"	4'-0"	-	-	2'-3"	12"	9"	#4 @ 48"	#5 @ 24"	-	#4 @ 24"
4'-8"	4'-8"	-	-	2'-3"	12"	9"	#4 @ 48"	#5 @ 24"	-	#4 @ 24"
5'-4"	5'-4"	-	-	2'-9"	12"	9"	#4 @ 48"	#5 @ 16"	-	#4 @ 24"
6'-0"	6'-0"	-	-	3'-3"	12"	9"	#5 @ 48"	#5 @ 16"	-	#4 @ 24"
6'-8"	4'-0"	2'-8"	-	3'-6"	12"	9"	#5 @ 32"	#5 @ 16"	-	#4 @ 24"
7'-4"	4'-8"	2'-8"	-	4'-0"	12"	9"	#5 @ 32"	#5 @ 16"	-	#4 @ 16"
8'-0"	4'-8"	3'-4"	-	4'-6"	12"	9"	#5 @ 32"	#5 @ 16"	-	#5 @ 16"
8'-8"	4'-8"	4'-0"	-	4'-9"	14"	9"	#5 @ 32"	#6 @ 16"	-	#5 @ 16"
9'-4"	4'-8"	4'-8"	-	5'-0"	15"	9"	#5 @ 32"	#6 @ 16"	-	#5 @ 16"
10'-0"	4'-8"	5'-4"	-	5'-3"	15"	9"	#5 @ 32"	#6 @ 8"	-	#6 @ 16"
10'-8"	4'-8"	6'-0"	-	5'-9"	15"	9"	#5 @ 32"	#6 @ 8"	-	#6 @ 16"
11'-4"	4'-8"	3'-4"	3'-4"	6'-3"	15"	9"	#5 @ 32"	#5 @ 16"	#6 @ 16"	#5 @ 8"
12'-0"	4'-8"	4'-0"	3'-4"	6'-6"	15"	9"	#5 @ 32"	#6 @ 16"	#6 @ 16"	#5 @ 8"
12'-8"	4'-8"	4'-8"	3'-4"	7'-0"	15"	9"	#5 @ 32"	#6 @ 16"	#6 @ 8"	#6 @ 8"
13'-4"	4'-8"	4'-8"	4'-0"	7'-6"	15"	12"	#5 @ 32"	#6 @ 16"	#6 @ 8"	#6 @ 8"
14'-0"	4'-8"	4'-8"	4'-8"	8'-0"	15"	15"	#5 @ 32"	#6 @ 16"	#6 @ 8"	#6 @ 8"
14'-8"	4'-8"	4'-8"	5'-4"	8'-3"	15"	15"	#5 @ 32"	#6 @ 16"	#6 @ 8"	#6 @ 8"

* FOR THIS HEIGHT WALL THE "X" BARS MAY BE ELIMINATED BY EXTENDING THE "Y" BARS TO THE TOP OF THE WALL.

** WHEN "H3" AND "H2" DO NOT EXIST, LOCATE THE "Y" BARS IN THE SAME POSITION AS THE "X" BARS. EXTEND THE "Y" BARS INTO THE MASONRY WALL 2'-0" MINIMUM FOR A #4 BAR, 2'-6" MINIMUM FOR A #5 BAR, AND 3'-0" FOR A #6 BAR. WHEN "H" IS LESS THAN 2'-0" CENTER "Y" BARS IN CENTER OF WALL.

RETAINING WALL W/LEVEL SLOPE DETAIL AND SCHEDULE

SCALE: 1/2" = 1'-0"

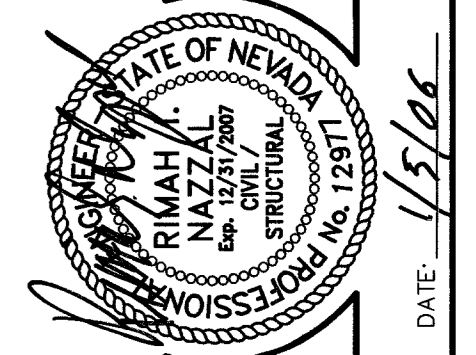

DESIGN	MJM	DATE
DRAWN	MJM/AN	
CHECK	RIN	
ISSUE DATE		
ISSUE DATE		
PLOT DATE	01-08-06	
PLOT TIME	10:25:05	
REV	DATE	DESCRIPTION

G. C. WALLACE, INC.
 Engineers/Planners/Surveyors
 100 SOUTH PARKWAY, SUITE 100, WASHINGTON, DC 20004
 TELEPHONE: (703) 804-2000 • FAX: (703) 804-2299
 G:\764-094-001\Draw\Imprev\094-001_S002.dwg YC09esi

PULTE HOMES, INC.
 EASTON PLACE AT PROVIDENCE - PHASE 2
 RETAINING WALL DETAILS