

**GENERAL NOTES**

1. ALL DESIGN ELEVATIONS ARE TO THE ROUGH GRADE ELEVATION, AND ARE 0.30' LOW TO ALLOW FOR LANDSCAPING.
2. ALL FINAL GRADE ELEVATIONS ON THE OUTSIDE OF BUILDINGS SHALL BE A MINIMUM OF 6" LOWER THAN THE ESTABLISHED FINISH FLOOR ELEVATION, EXCEPT AT THE ENTRANCE OF THE BUILDING.
3. THE CONTRACTOR SHALL VERIFY ALL ASPECTS OF THESE PLANS AND REPORT ANY DISCREPANCIES TO THE ENGINEER PRIOR TO COMMENCEMENT OF ANY WORK.
4. ANY QUANTITIES SHOWN HEREON ARE FOR ESTIMATING ONLY AND ARE NOT TO BE USED FOR BIDDING.
5. THE CONTRACTOR SHALL FURNISH TO THE ENGINEER AS-BUILT DRAWINGS FOR UTILITY SERVICES AND HOOK-UPS.
6. REFER TO THE IMPROVEMENT PLANS FOR STREET SECTIONS, DETAILS AND NEW UTILITY LOCATIONS.
7. ALL GRADING SHALL CONFORM TO THE SOILS REPORT BY WESTERN TECHNOLOGIES INC. PROJ NO. 412K268 DATED: NOV 19, 1991
8. ALL WORK PERFORMED OUTSIDE THE PROJECT BOUNDARY AND ON PRIVATE PROPERTY SHALL NOT BE PERFORMED UNTIL WRITTEN PERMISSION AND EASEMENT HAS BEEN OBTAINED FROM THE PROPERTY OWNER.
9. PROVIDE 6" THICK CONCRETE SIDEWALK WHERE DRIVEWAYS ARE TO BE LOCATED.

NOTE: THE SPECIFIED RETAINING WALLS ARE A NON-STANDARD CITY OF LAS VEGAS RETAINING WALL DESIGN. STRUCTURAL CALCULATIONS AND SOILS REPORT SHALL BE SUBMITTED TO THE CITY OF LAS VEGAS BUILDING DEPT. FOR REVIEW AND APPROVAL PRIOR TO WALL CONSTRUCTION PERMIT ISSUANCE.

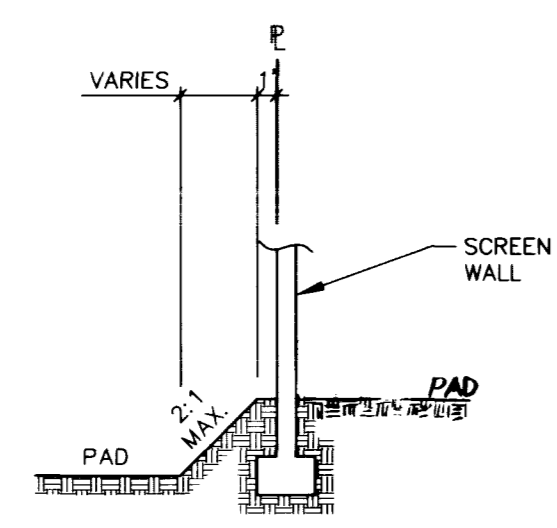

SECTION A  
NOT TO SCALE

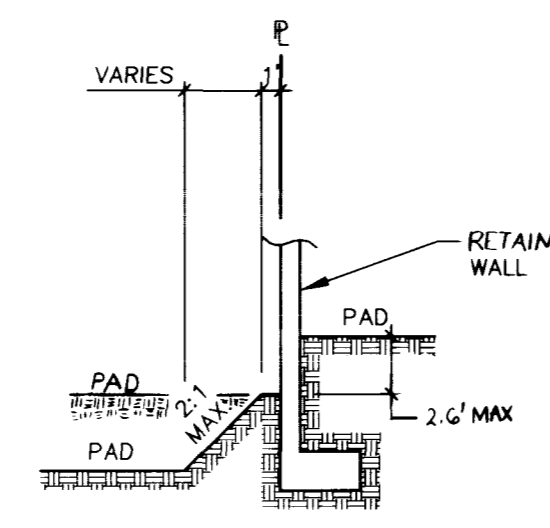

SECTION B  
NOT TO SCALE

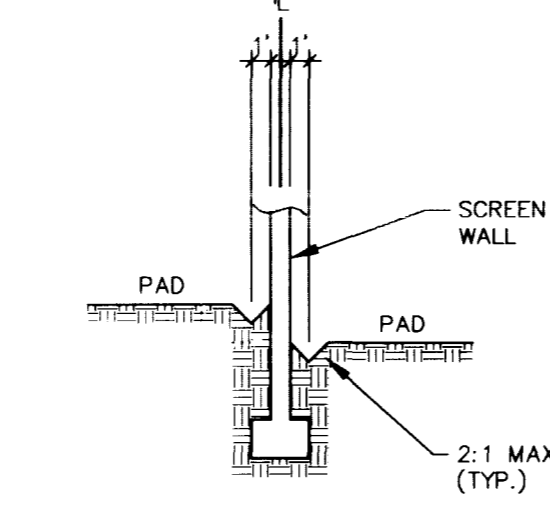

SECTION C  
NOT TO SCALE

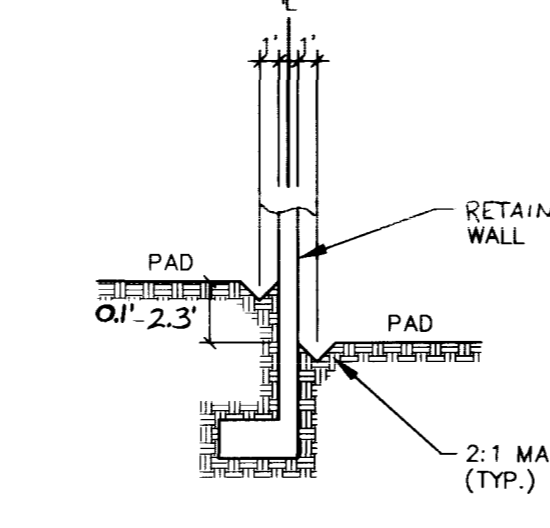

SECTION D  
NOT TO SCALE

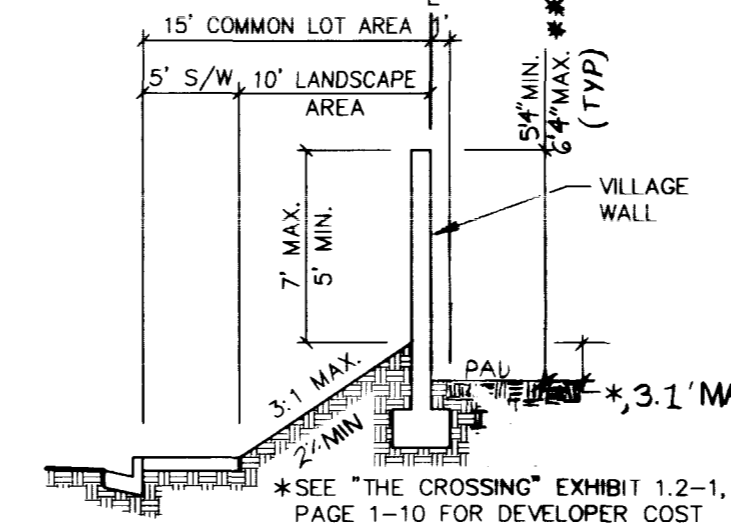

SECTION E  
NOT TO SCALE

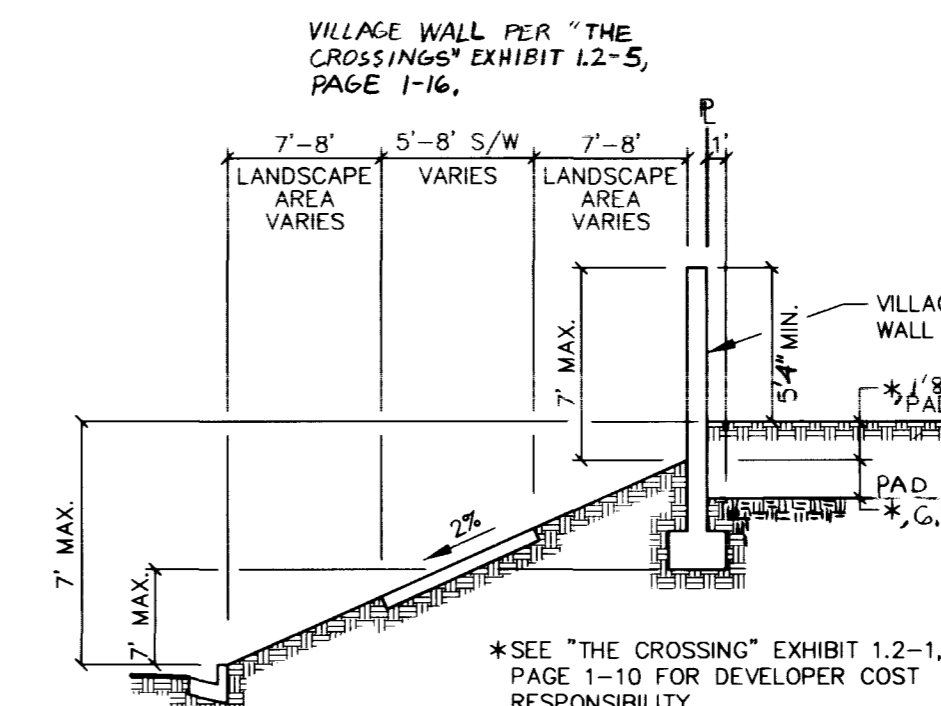

SECTION F  
NOT TO SCALE

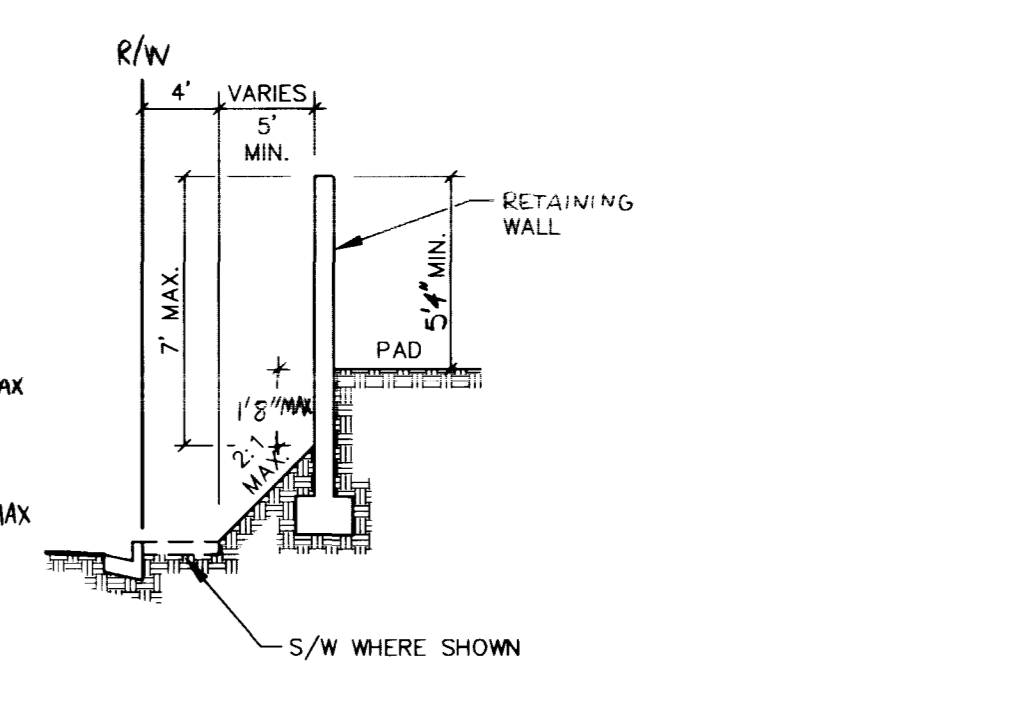

SECTION G  
NOT TO SCALE

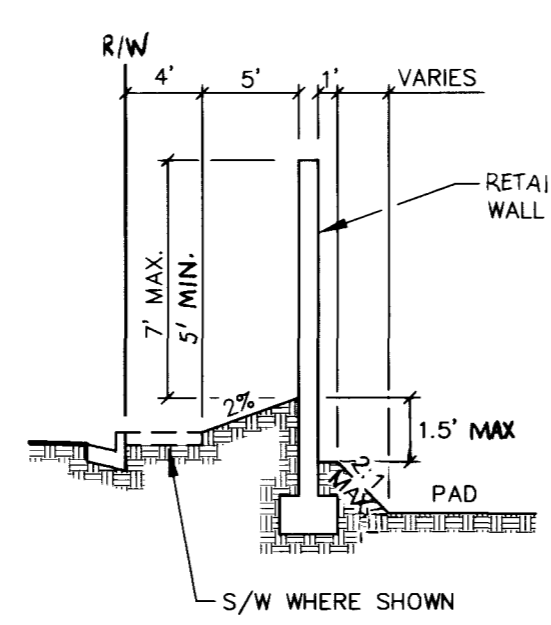

SECTION H  
NOT TO SCALE

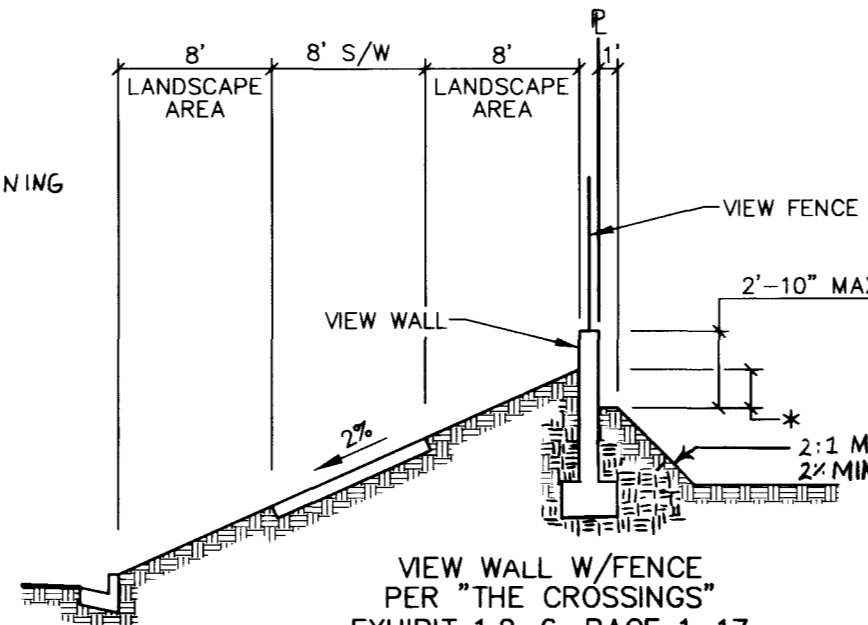

SECTION J  
NOT TO SCALE

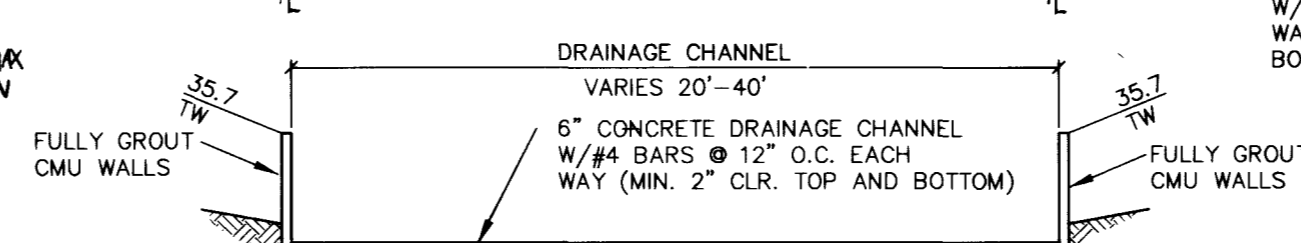

SECTION L  
NOT TO SCALE

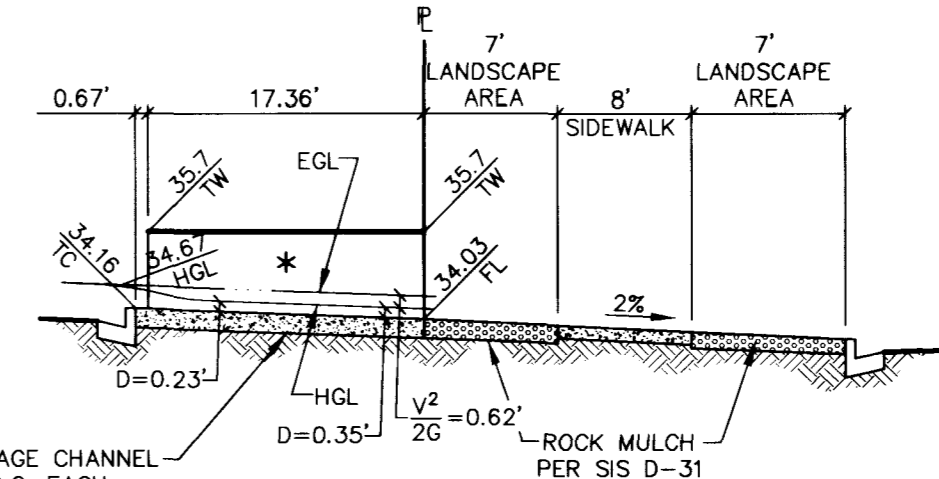

SECTION M  
NOT TO SCALE

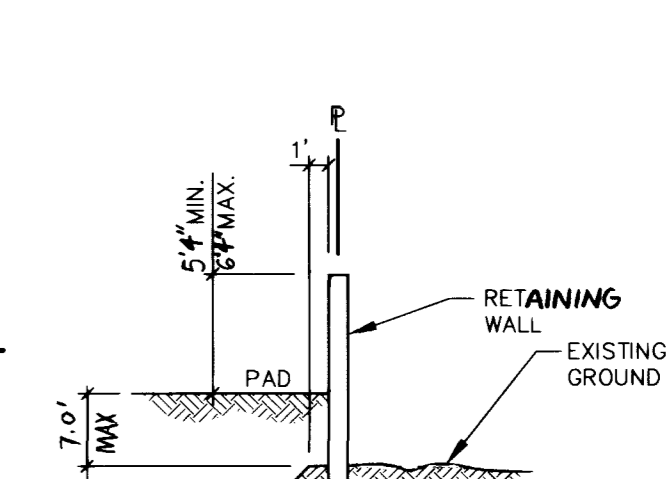

SECTION N  
NOT TO SCALE

NOTE FOR DETAIL "Q"  
MAXIMUM RAMP SLOPE = 1:12  
MAXIMUM SIDE SLOPE = 2%  
SIDEWALK RAMP PER ADA 4.8 & SIS #S-72  
HANDRAILS PER ADA 4.8.5  
LANDING

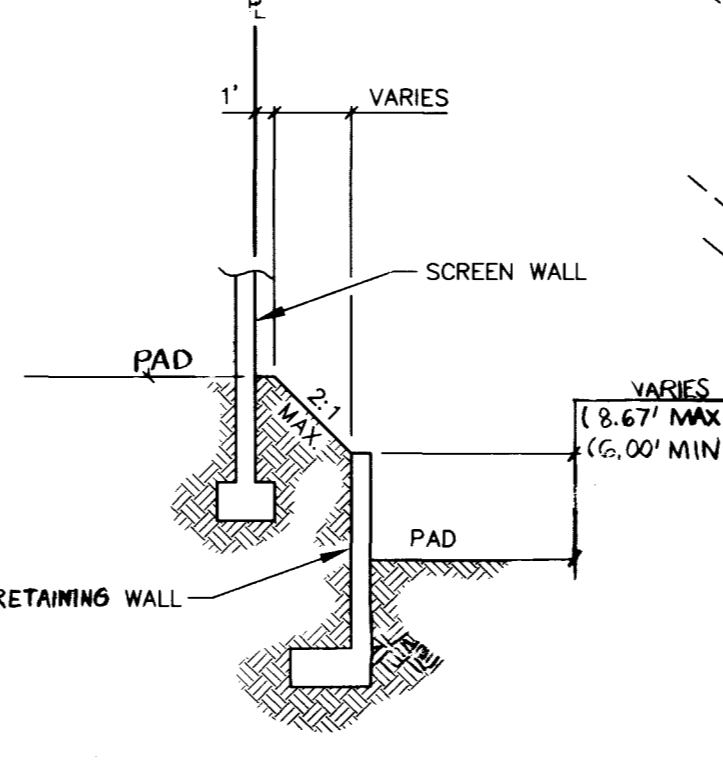

SECTION O  
NOT TO SCALE

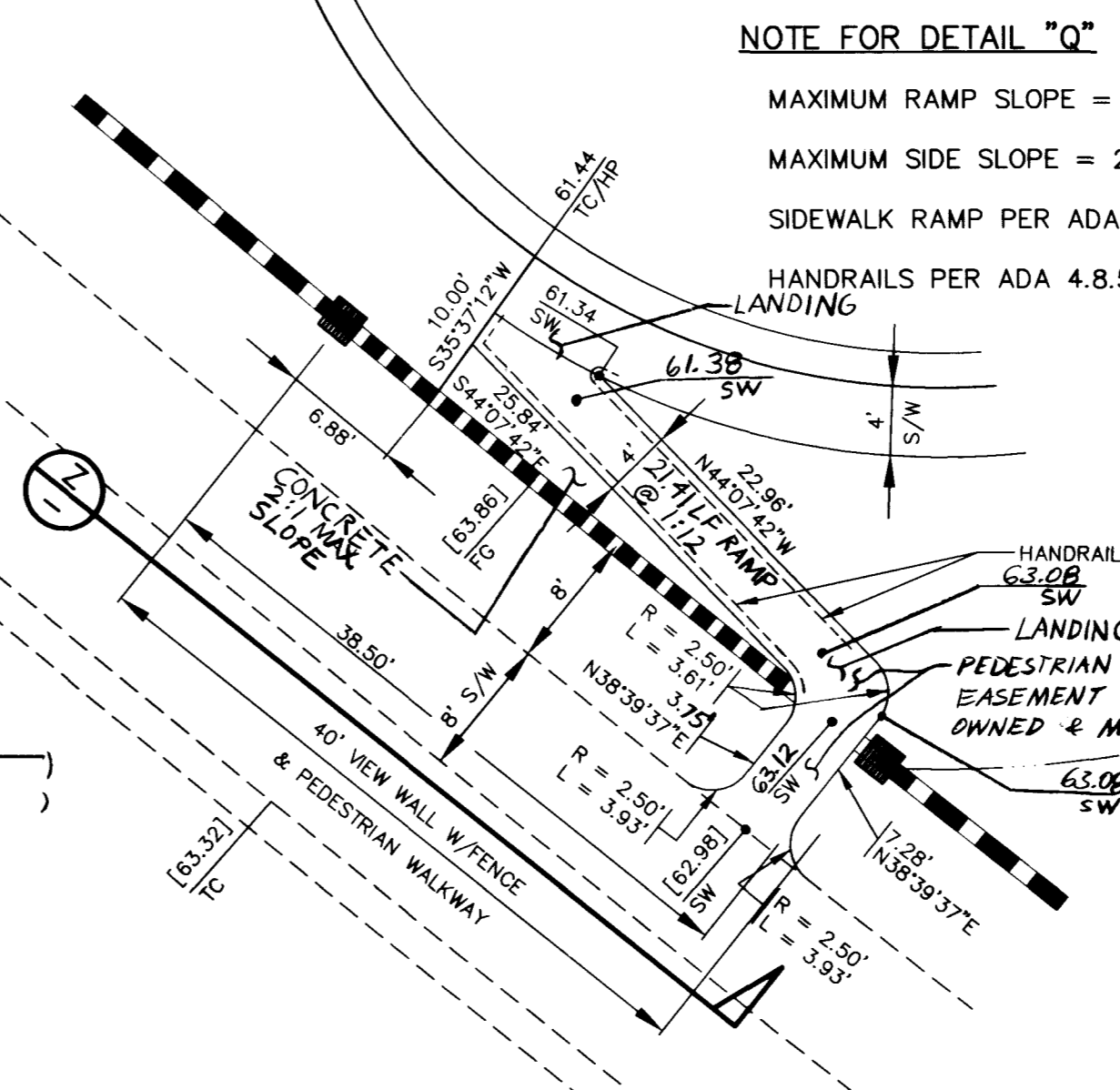

SECTION Q  
1" = 10"

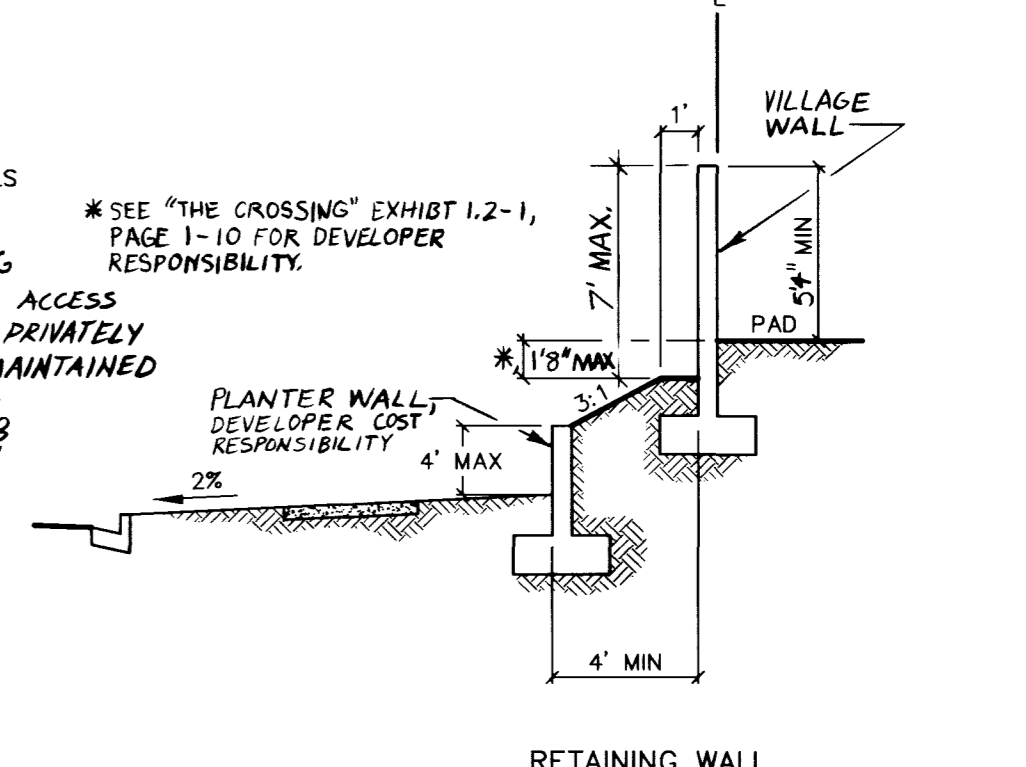

SECTION R  
NOT TO SCALE

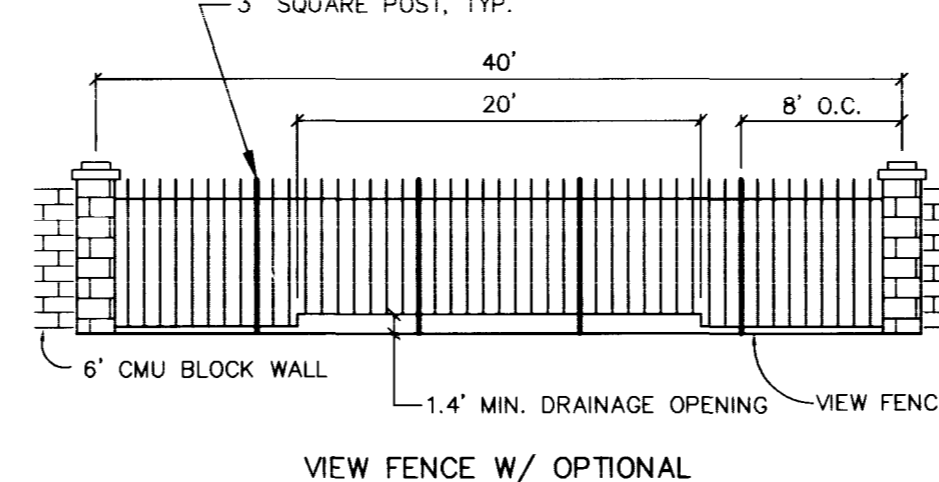

SECTION S  
NOT TO SCALE

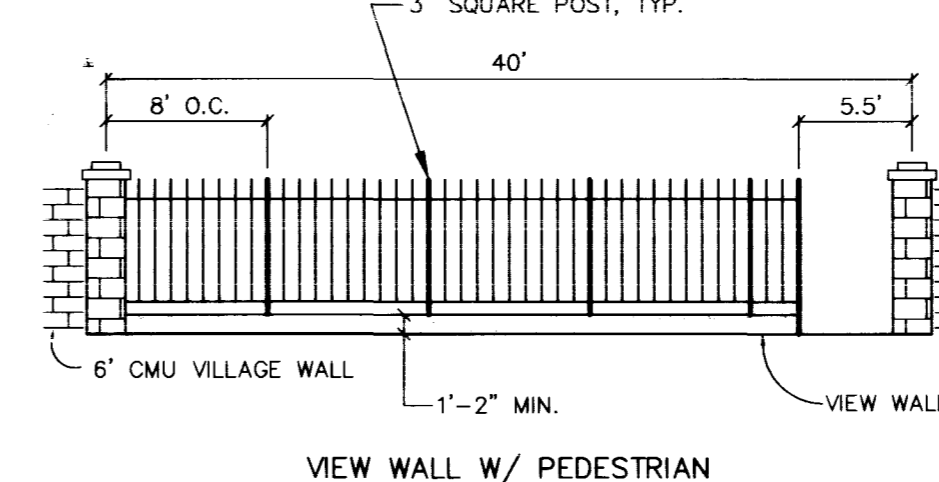

SECTION Z  
NOT TO SCALE

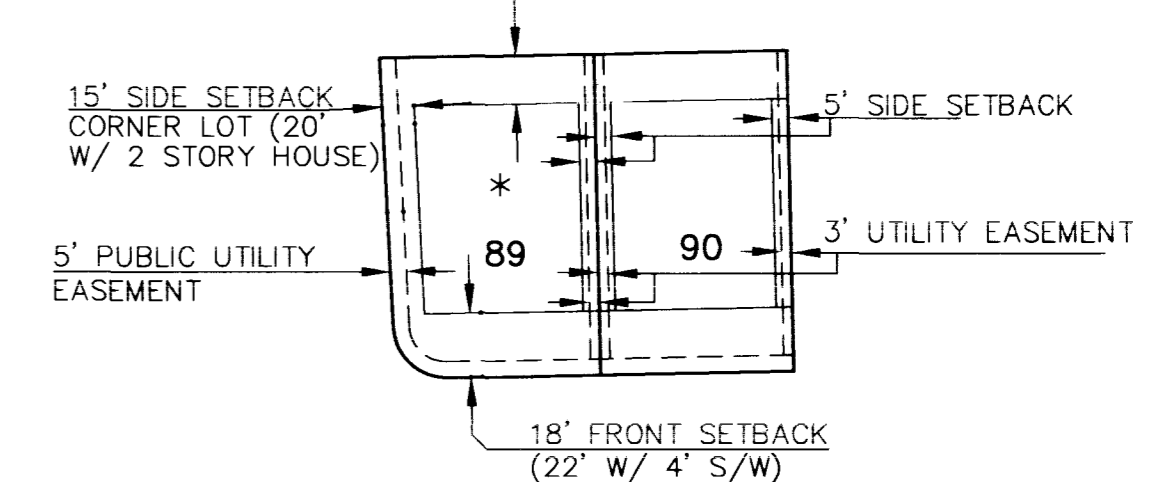

TYPICAL LOT SETBACK DETAIL  
NOT TO SCALE

**TYPICAL LOT DRAINAGE**

N.T.S.  
THE SLOPE FROM THE FOUNDATION TO THE SWALE AT 2% MIN. - 2% MAX.  
THE SLOPE FROM THE PROPERTY LINE TO THE SWALE AT 2% MIN. - 2% MAX.

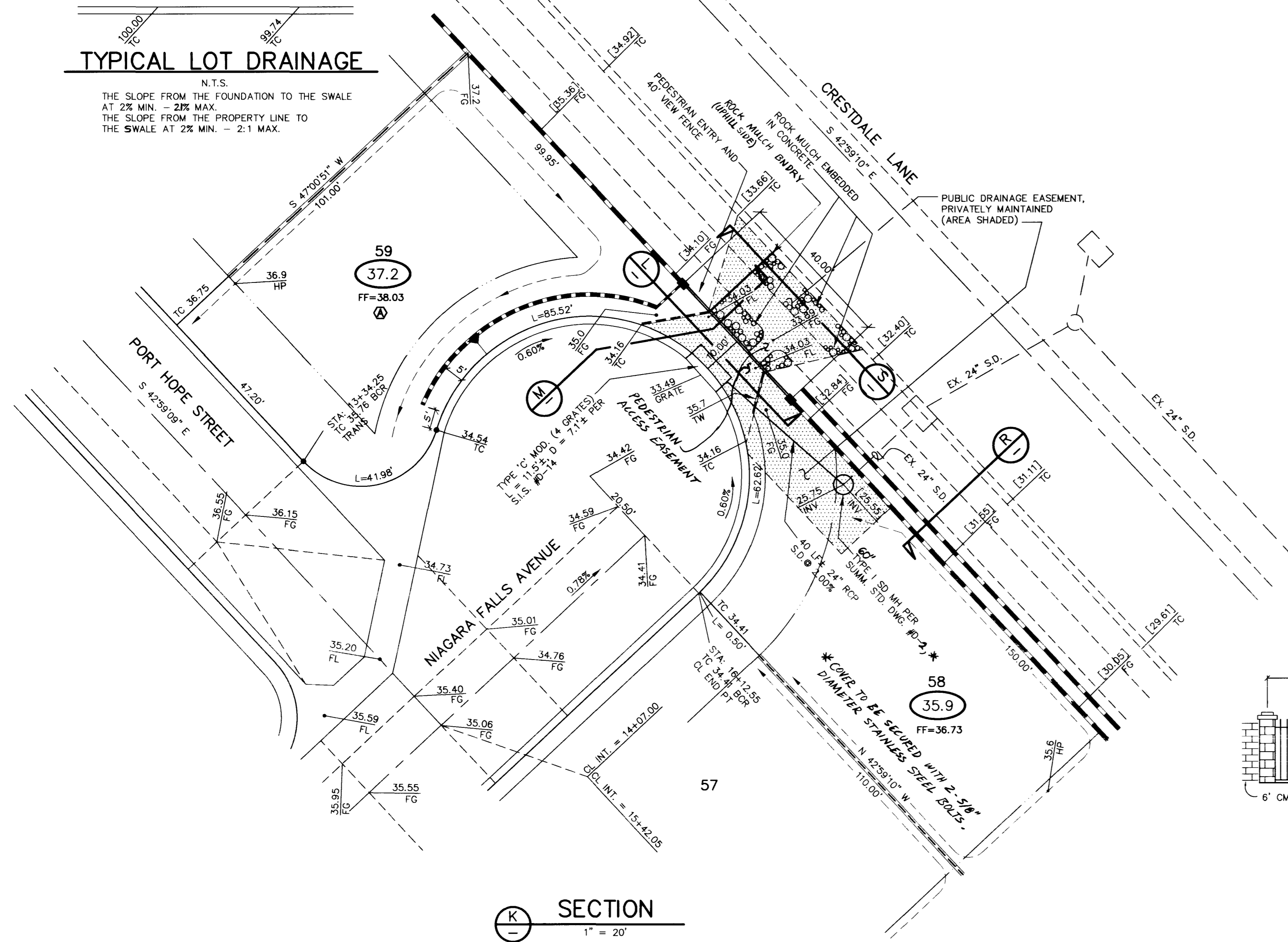

NO.	DATE	BY	APP'D	REVISION DESCRIPTION

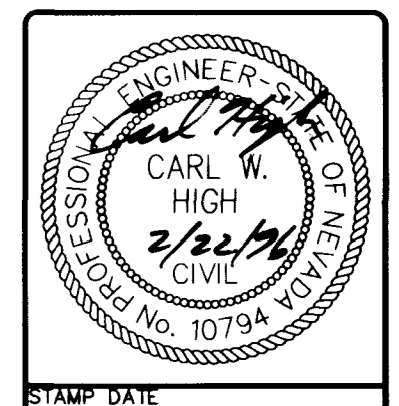

SOUTHWEST ENGINEERING  
LAND PLANNING • MAPING • DEVELOPMENT  
506 W. VEGAS DRIVE  
LAS VEGAS, NEVADA 89108  
(702) 648-9700

GRADING DETAILS & NOTES  
**DISCOVERY POINTE**  
UNIT 1  
PROJECT  
WORK ORDER NO. 950303  
DESIGN BY: C.H.  
DATE: 05/06/96  
SCALE: NONE  
CADD FILE: DP1GDETS.DWG  
SHEET 5 OF 14 SHEETS  
1074-4471-1

