

161726

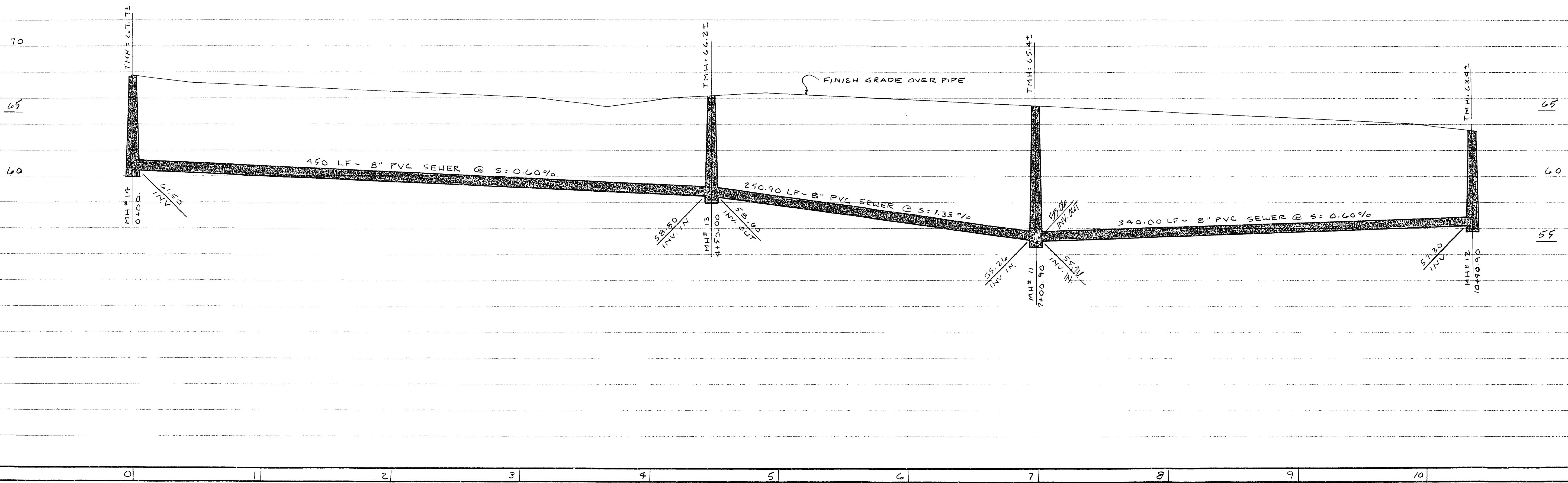

0 1 2 3 4 5 6 7 8 9 10

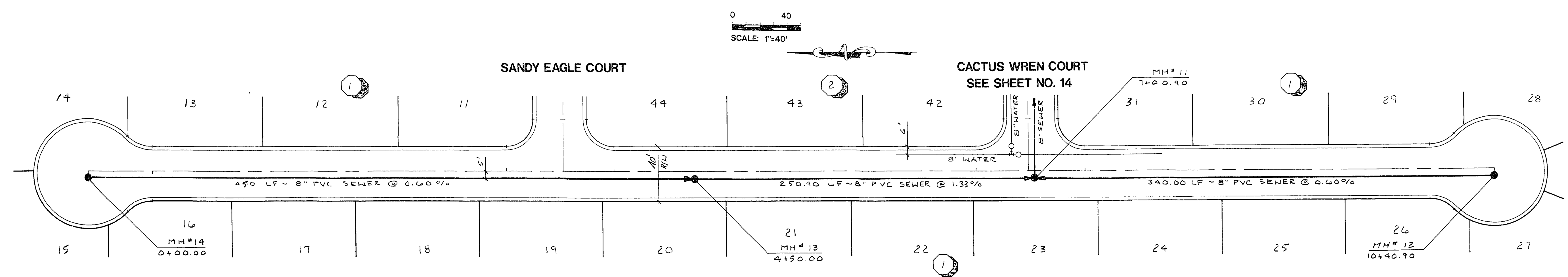

**DREAM CATCHER AVENUE**  
CV. PUBLIC SEWER FACILITY

**BENCHMARK**  
BM # 1C90-32SES  
RIVET AND PLATE IN CONC. MON. 3 FT.  
NORTHWEST OF STOP SIGN, 60 FT. NORTH  
AND 30 FT. WEST OF DURANGO DR. AND  
LONE MOUNTAIN ROAD.  
ELEVATION = 2411.56

2 working days  
**Call before you Dig**  
1-800-227-2800

**DAILY HOMES**  
CLARK COUNTY, NEVADA

CONSULTING ENGINEERS • PLANNERS • LAND SURVEYORS  
2727 SOUTH RAINBOW BOULEVARD  
LAS VEGAS, NEVADA 89102-5148 PHONE (702) 873-7550 FAX (702) 362-2597

**vtm** nevada

REV	DATE	BY	REVISION
1	4/10/02	WJR	REMOVE DATE SH. PER CLIENT

**SEWER PLAN - PROFILE**  
DREAM CATCHER AVENUE  
EAGLE RIDGE

TITLE PROJECT

NO. 4717  
BY R5 WJR  
DATE 11/94  
SCALE HORIZ. 1"=40'  
VERT. 1"=2'

SHEET **16** OF 18 SHEETS

11-21-13/ 330079 3074-4395