

TYPICAL BUILDING PAD PLAN VIEW - TOWN HOMES
NO SCALE

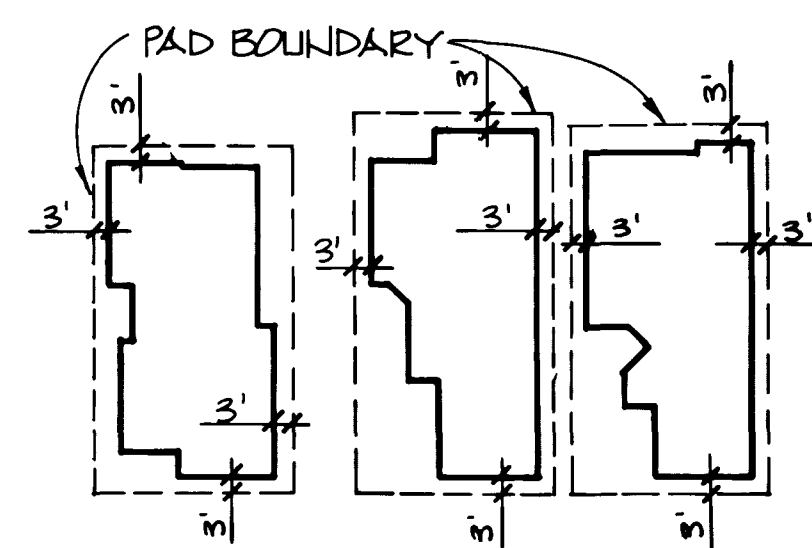

TYPICAL BUILDING PAD PLAN VIEW - PATIO HOMES
NO SCALE

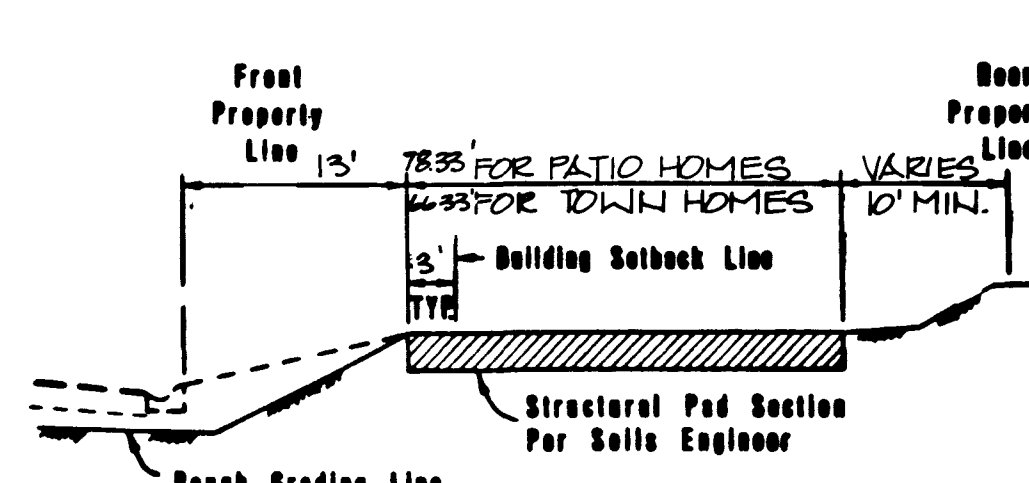

TYPICAL GRADING SECTION
NO SCALE

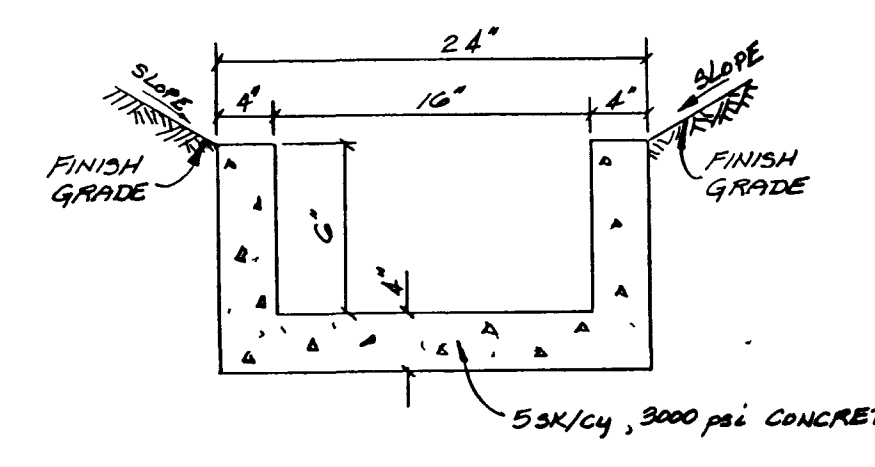

2' CONCRETE SWALE
NO SCALE

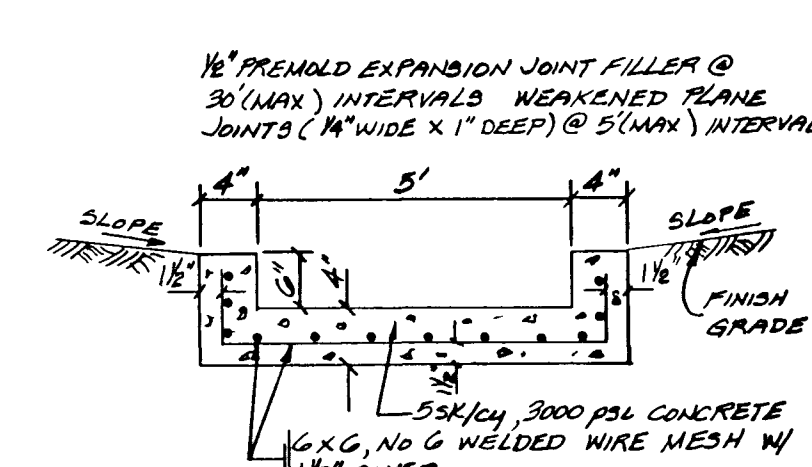

5' CONC. SW. W/0.5' CURB
NO SCALE

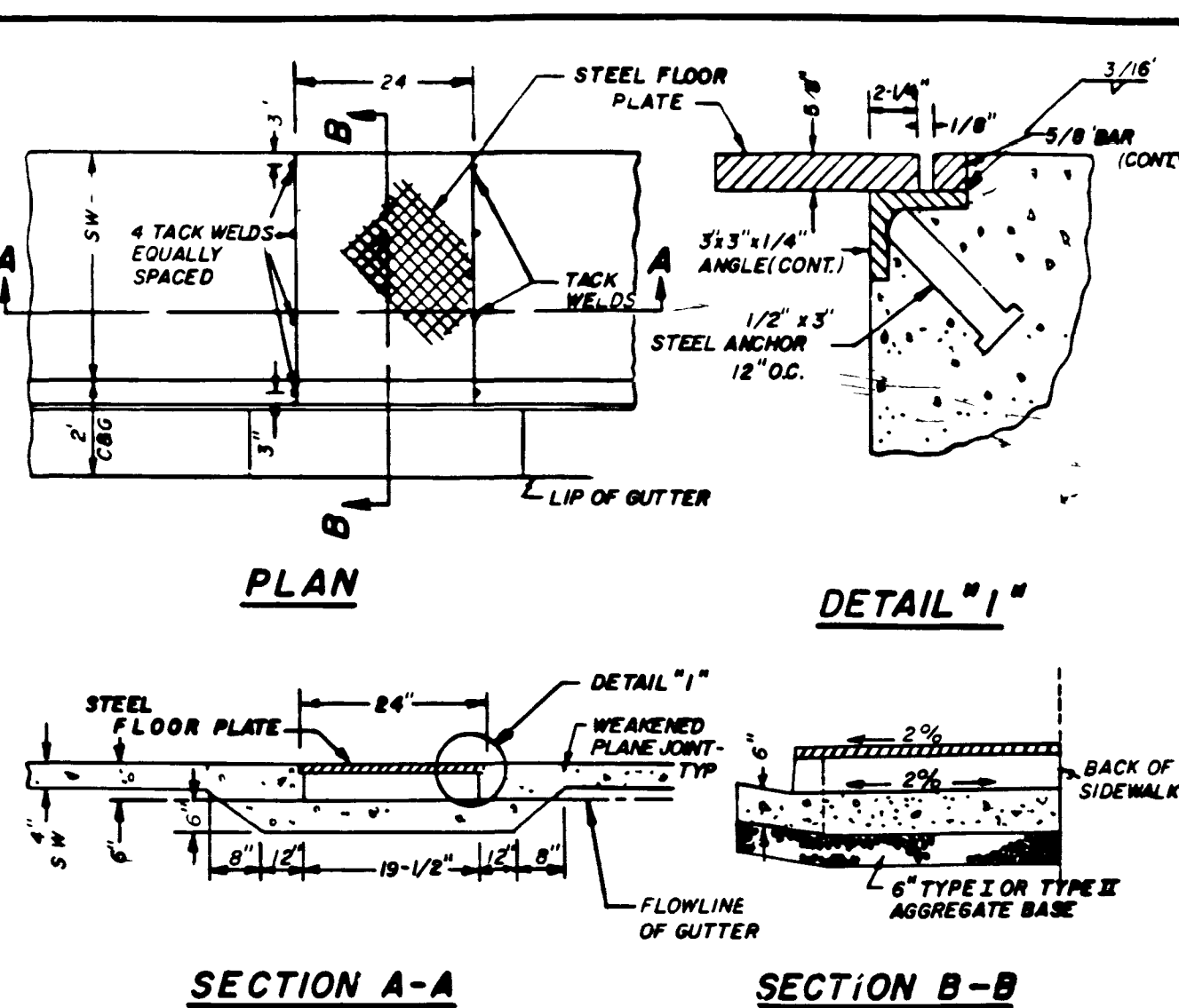

SECTION A-A

SECTION B-B

NOTES

- IF WIDTH OF PLATE IS GREATER THAN 24", A SPECIAL DESIGN IS REQUIRED
- ALL EXPOSED METAL PARTS SHALL BE GALVANIZED AND ALL GALVANIZING DAMAGED BY FABRICATION OR INSTALLATION SHALL RECEIVE TWO COATS OF ALUMINUM PAINT (GALYNOX OR EQUAL)

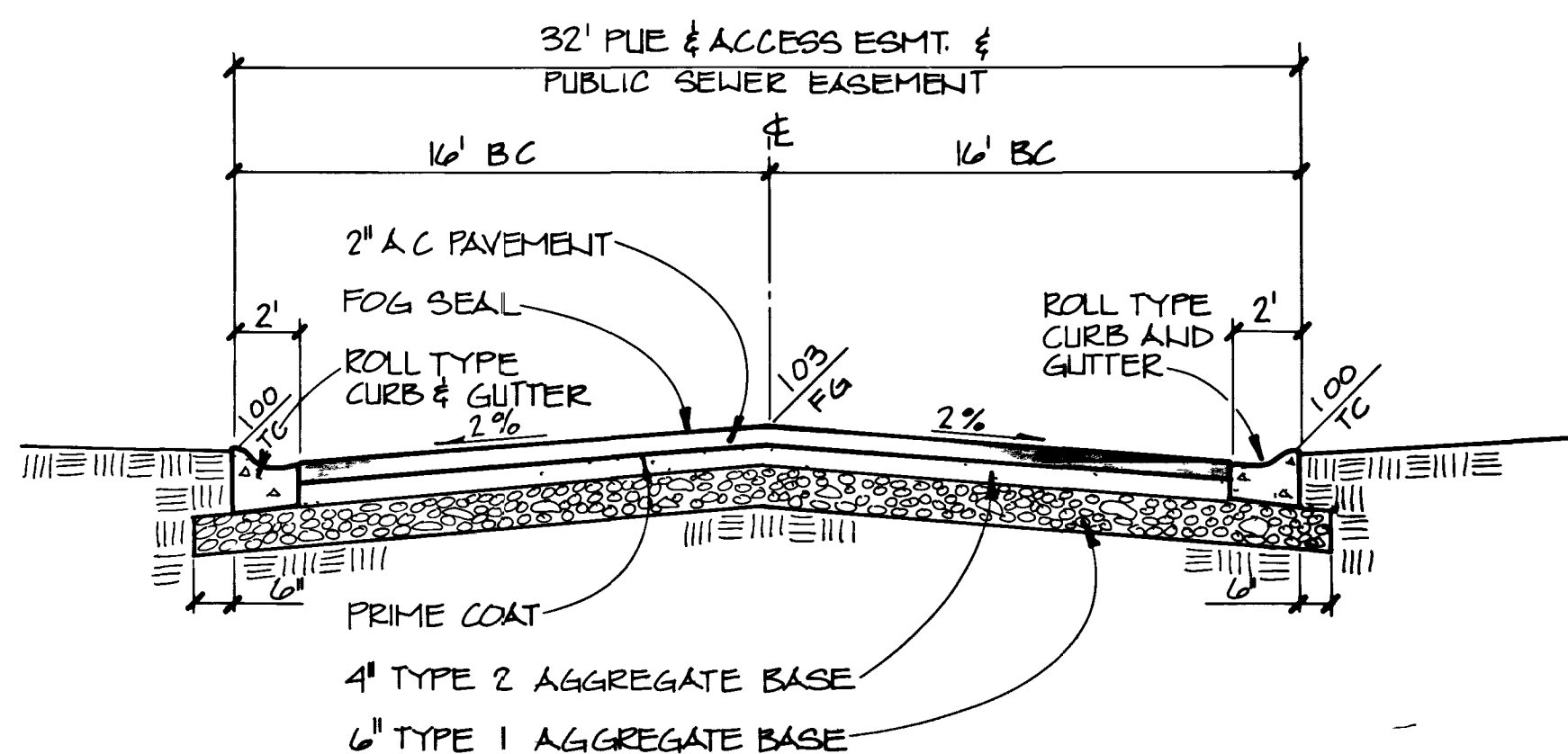

TYPICAL 32' R/W STREET SECTION
NO SCALE

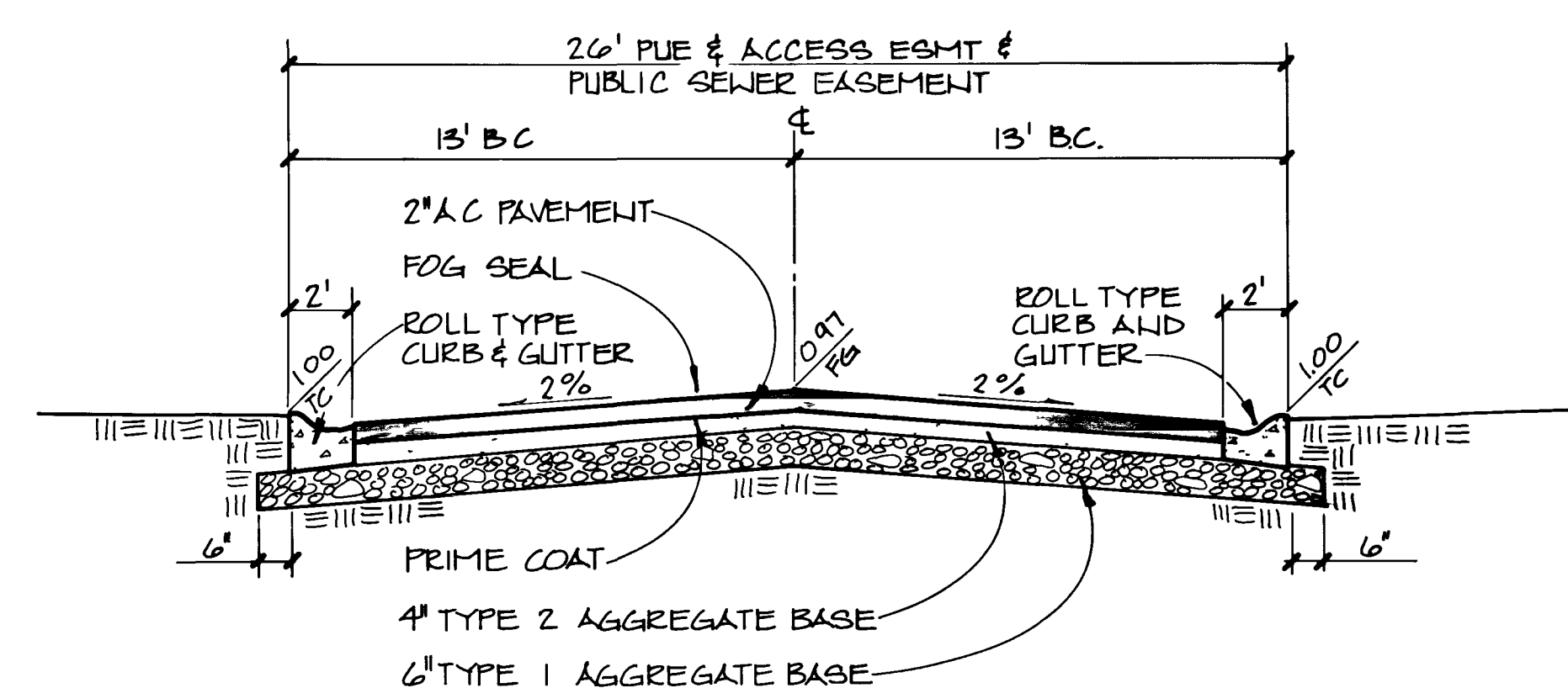

TYPICAL 26' R/W STREET SECTION
NO SCALE

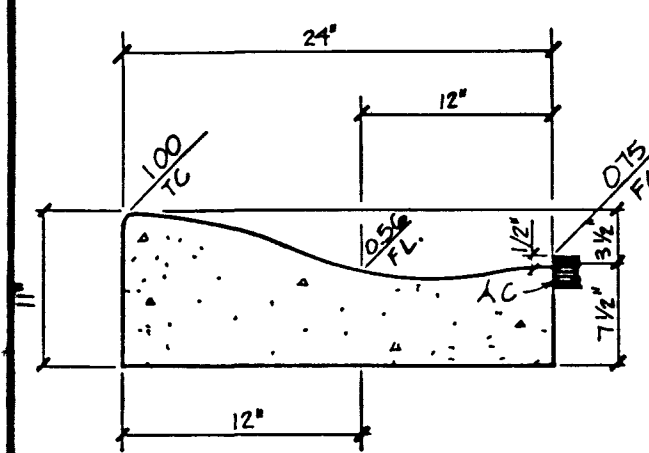

TYPICAL ROLL CURB
NO SCALE

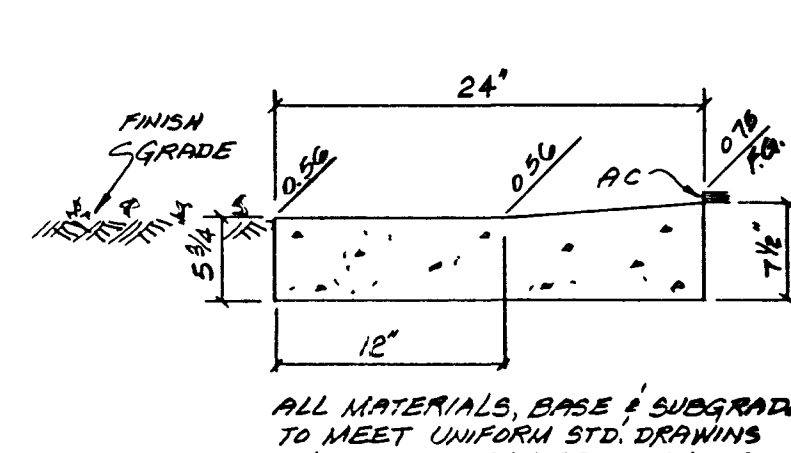

TYPICAL DEPRESSED CURB
NO SCALE

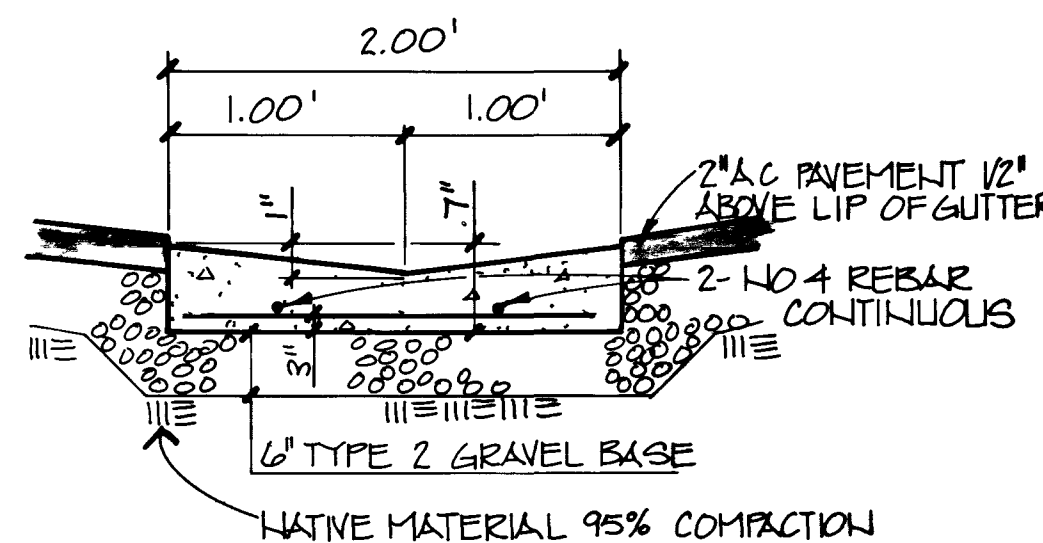

TYPICAL 2' VALLEY GUTTER
NO SCALE

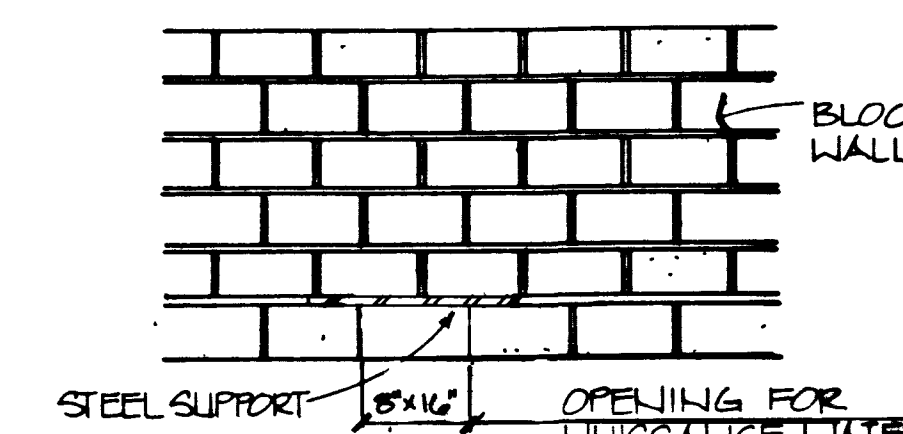

BLOCK WALL OPENING DETAIL
NO SCALE

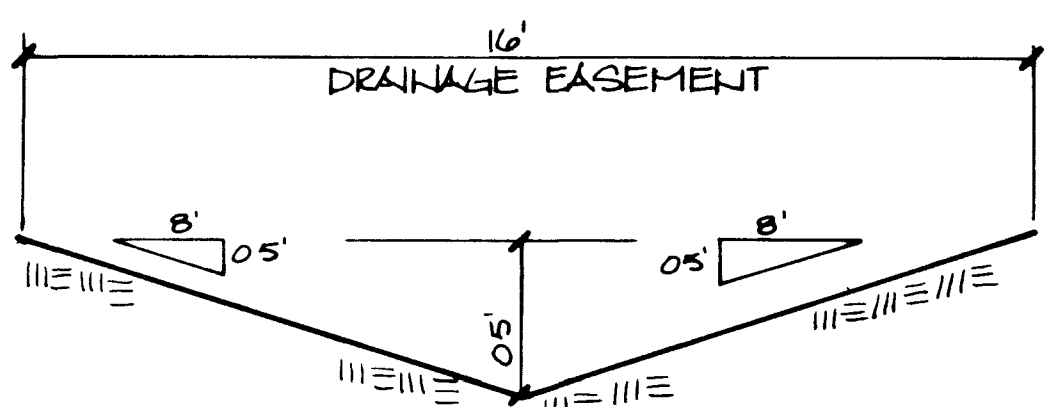

EARTH SWALE DETAIL
NO SCALE

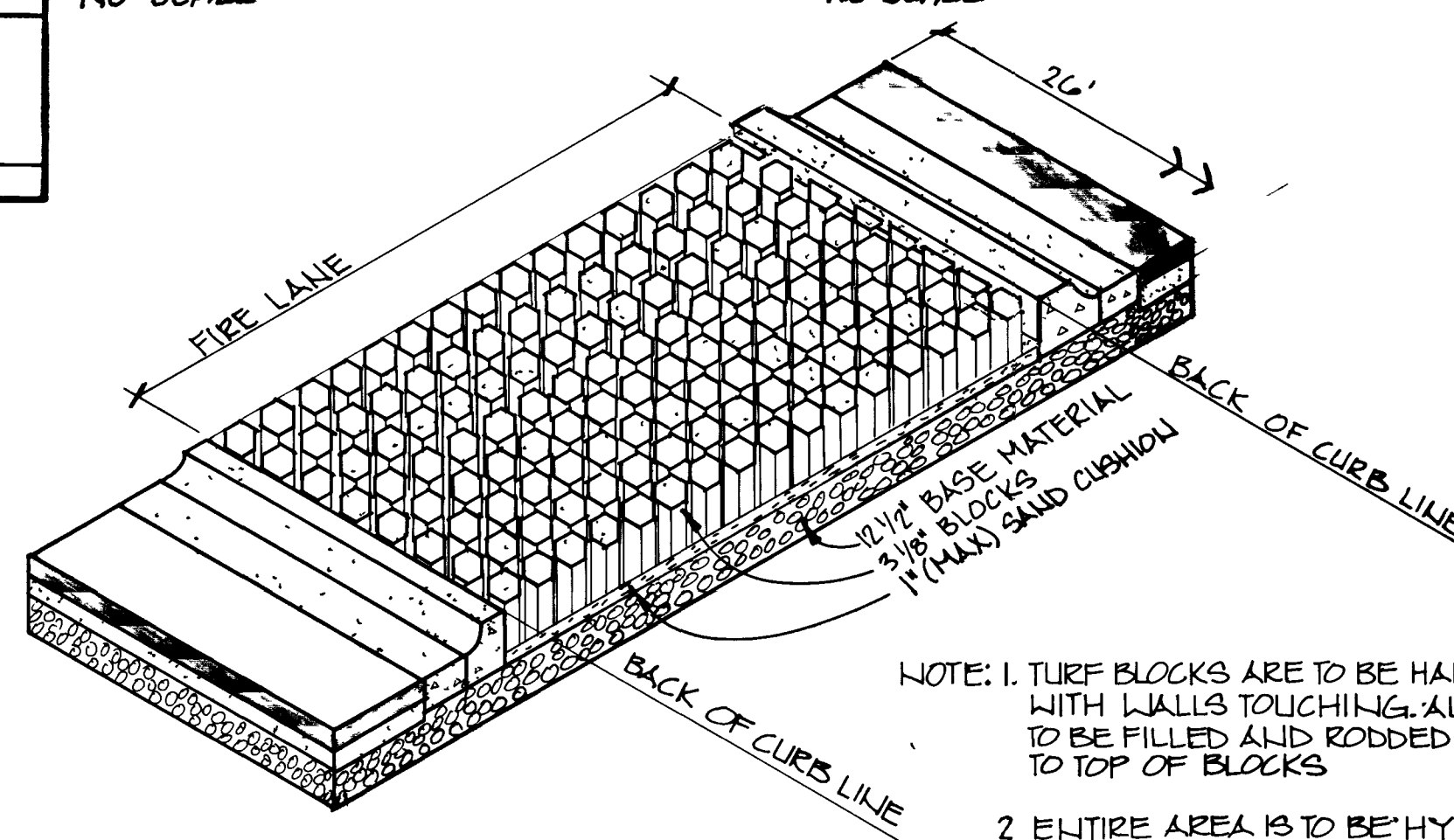

TURF BLOCK PAVEMENT DETAIL
NO SCALE

- NOTE: 1. TURF BLOCKS ARE TO BE HAND PLACED WITH WALLS TOUCHING. ALL VOIDS ARE TO BE FILLED AND RODDED IN 2' LIFTS TO TOP OF BLOCKS
2. ENTIRE AREA IS TO BE HYDRO MULCHED WITH SEED MIXTURE SUITABLE AT TIME OF PLANTING.
3. USE TURFSTONE OR EQUIVALENT PAVEMENT MATERIAL AND SPECIFICATIONS.

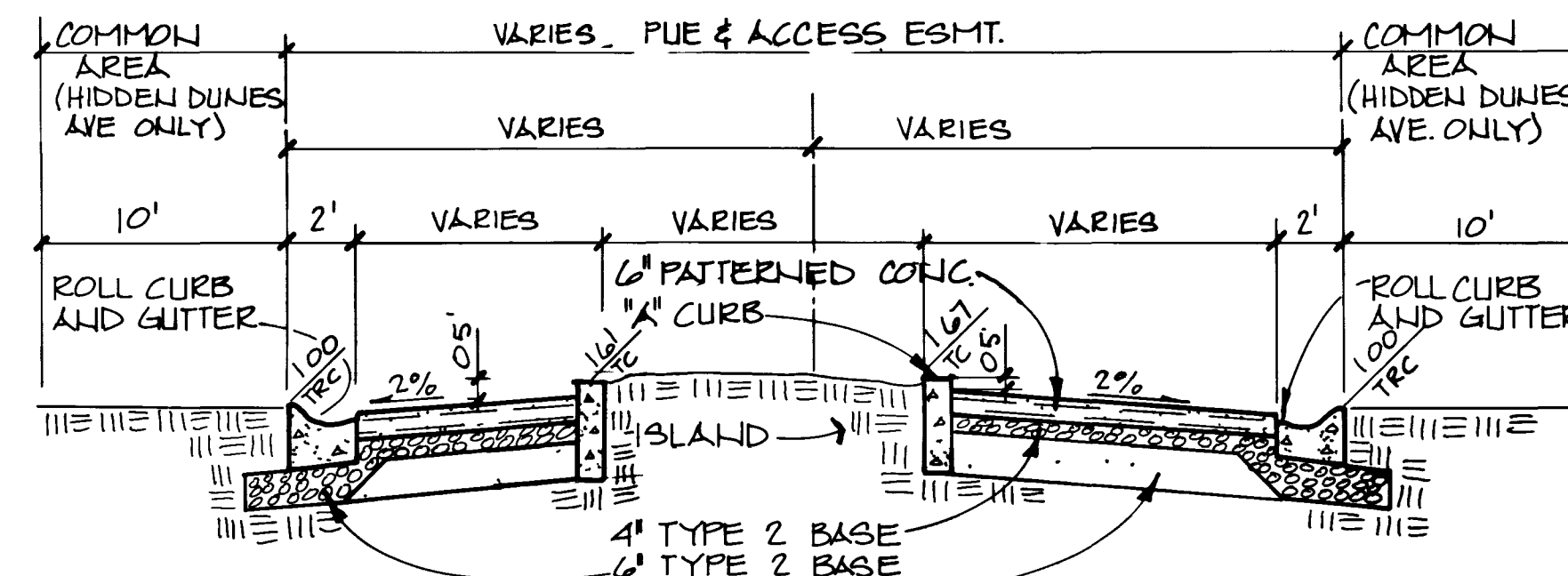

ENTRY STREET SECTION
NO SCALE

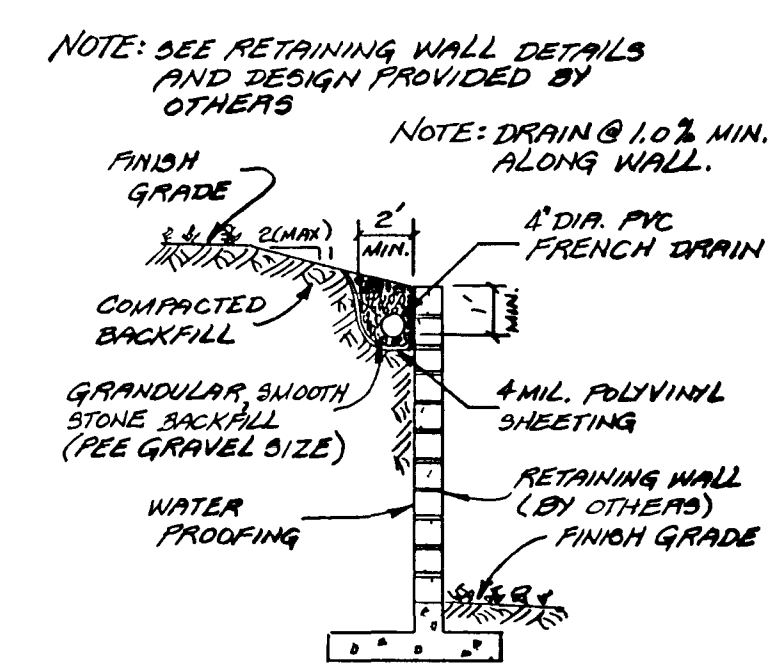

RETAINING WALL FRENCH DRAIN
NO SCALE

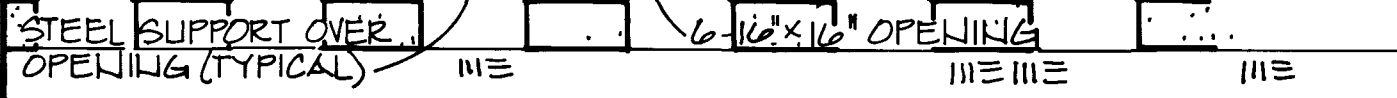

BLOCK WALL OPENING DETAIL AT SWALE
NO SCALE

- PLACE VEE EARTH SWALE BOTTOM TO FULL HEIGHT OF OPENINGS WITHIN 5' OF WALL BOTH SIDES
- SEE STRUCTURAL PLANS FOR WALL FOOTINGS.

NOTE

ALL MATERIALS, LABOR, AND WORKMANSHIP SHALL CONFORM TO THE LATEST CITY OF LAS VEGAS STANDARDS AND SPECIFICATIONS INCLUDING THE "UNIFORM STANDARD DRAWINGS FOR PUBLIC WORKS" CONSTRUCTION OFF-SITE IMPROVEMENTS CLARK COUNTY AREAS NEVADA, 1988. THESE DOCUMENTS ARE CONSIDERED A PART OF THESE PLANS AND SPECIFICATIONS.

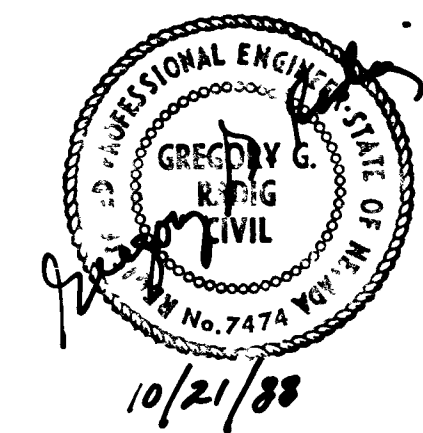

REVISION

REV	DATE	BY	DESCRIPTION
1	01/22/89	PV	MODIFY ENTRY STREET SECTION
2	01/29/89	EST	REV SIDEWALK DRAIN DETAIL

BERGHEER NEVADA
CITY OF LAS VEGAS

CONSULTING ENGINEERS - PLANNERS
2300 PASEO DEL PRADO BUILDING A SUITE 100
LAS VEGAS, NEVADA 89102 PHONE (702) 873-7550

vtm nevada

DETAILS

PROJECT
DESERT SHORES RACQUET CLUB (LOT 9)

TITLE

NO NO 3691
BY PV/FC
DATE OCT, 1988
SCALE NO SCALE

SHEET
13
OF 13 SHEETS

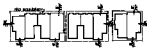

TYPICAL BUILDING NO. 2 PLAN VIEW - THREE UNITS



TYPICAL BUILDING NO. 2 PLAN VIEW - WIDE CORNER



TYPICAL BUILDING NO. 2 PLAN VIEW - WIDE CORNER



TYPICAL BUILDING NO. 2 PLAN VIEW - WIDE CORNER



TYPICAL BUILDING NO. 2 PLAN VIEW - WIDE CORNER

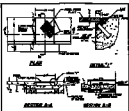

1. ALL DIMENSIONS ARE IN FEET AND INCHES.
 2. ALL DIMENSIONS ARE TO FACE UNLESS OTHERWISE NOTED.
 3. ALL DIMENSIONS ARE TO FACE UNLESS OTHERWISE NOTED.

NO.	DESCRIPTION
1	FOUNDATION
2	FOUNDATION
3	FOUNDATION
4	FOUNDATION
5	FOUNDATION
6	FOUNDATION
7	FOUNDATION
8	FOUNDATION
9	FOUNDATION
10	FOUNDATION
11	FOUNDATION
12	FOUNDATION
13	FOUNDATION
14	FOUNDATION
15	FOUNDATION
16	FOUNDATION
17	FOUNDATION
18	FOUNDATION
19	FOUNDATION
20	FOUNDATION
21	FOUNDATION
22	FOUNDATION
23	FOUNDATION
24	FOUNDATION
25	FOUNDATION
26	FOUNDATION
27	FOUNDATION
28	FOUNDATION
29	FOUNDATION
30	FOUNDATION
31	FOUNDATION
32	FOUNDATION
33	FOUNDATION
34	FOUNDATION
35	FOUNDATION
36	FOUNDATION
37	FOUNDATION
38	FOUNDATION
39	FOUNDATION
40	FOUNDATION
41	FOUNDATION
42	FOUNDATION
43	FOUNDATION
44	FOUNDATION
45	FOUNDATION
46	FOUNDATION
47	FOUNDATION
48	FOUNDATION
49	FOUNDATION
50	FOUNDATION



EARTH WALL DETAIL

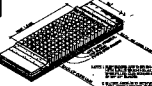

BRICK WALL DETAIL



TYPICAL 24' R/W STREET SECTION



TYPICAL 24' R/W STREET SECTION



TYPICAL WALL DETAIL



TYPICAL WINDOW DETAIL



TYPICAL DOOR DETAIL



BLOCK WALL OPENING DETAIL



BLOCK WALL OPENING DETAIL AT TOP



A 24' STREET SECTION



RETAINING WALL DETAIL

DESIGNED BY
 CITY OF LOS ANGELES
 DEPARTMENT OF PUBLIC WORKS
 PLANNING
 DIVISION

DESIGNED BY
 CITY OF LOS ANGELES
 DEPARTMENT OF PUBLIC WORKS
 PLANNING
 DIVISION

DETAILS
 DENSITY GRADES FACILITY CLIPS
 PART 31

NO. 12
 1977-09-14

