

BLOCK WALL DETAIL 1
NO SCALE

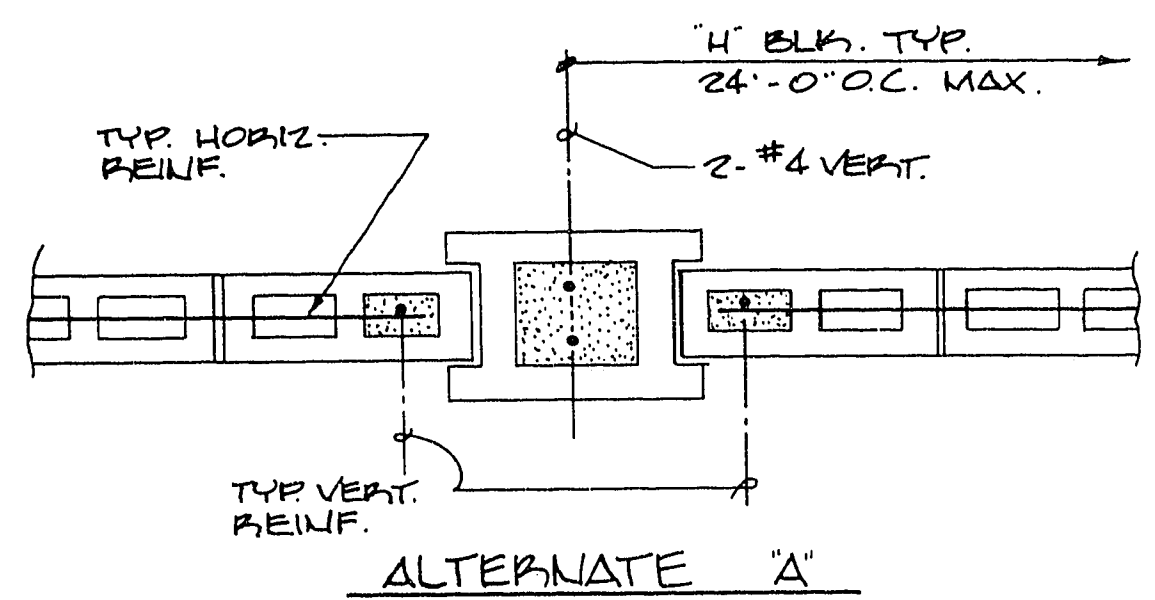

ALTERNATE 'A'

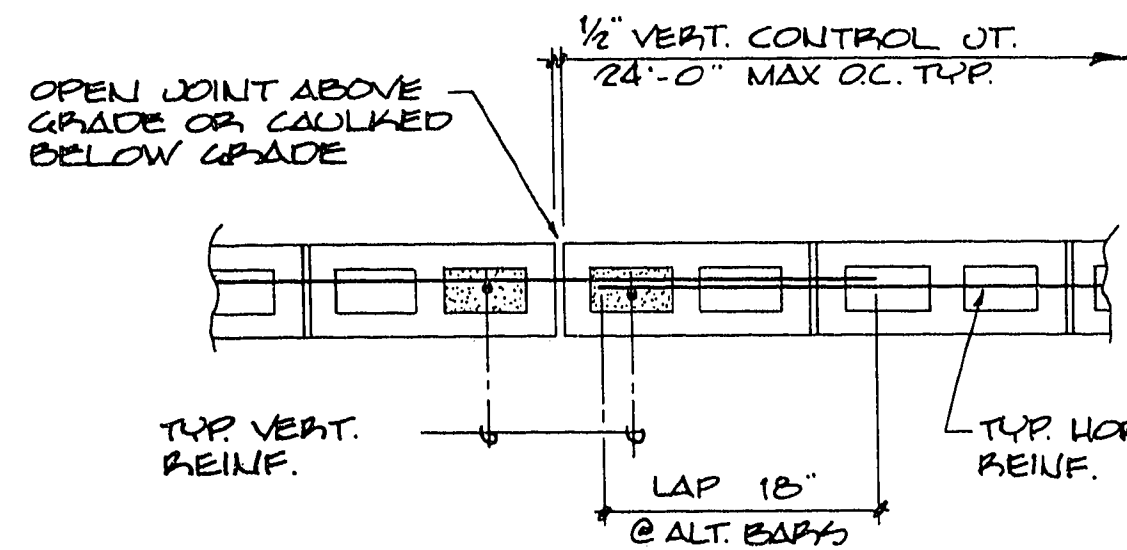

ALTERNATE 'B'

TYPICAL CONTROL JOINT

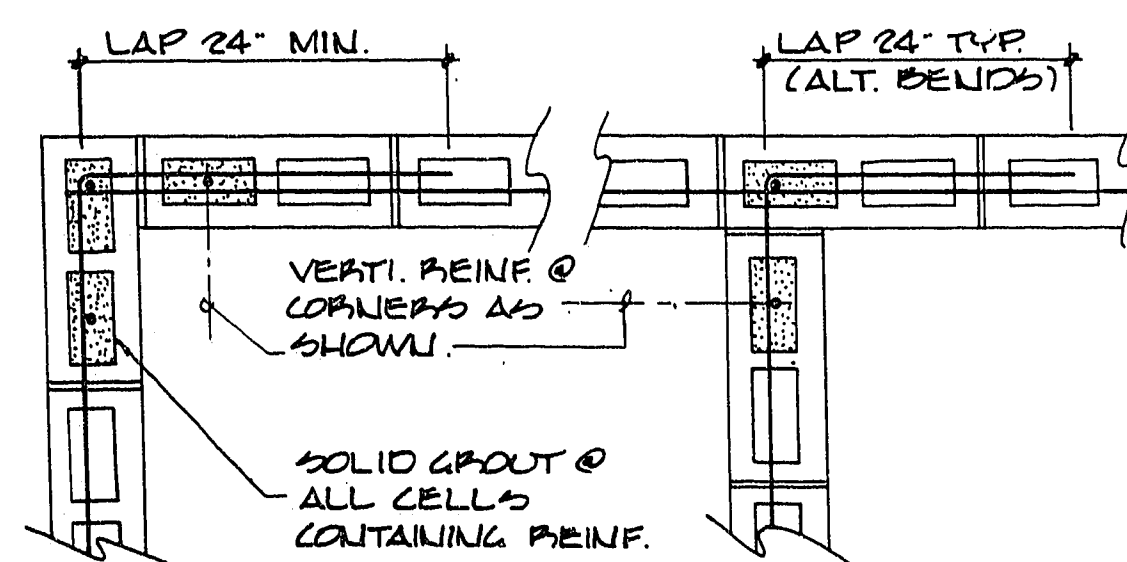

NOTE:

1. CORNER BARS (C) MAY BE USED IN LIEU OF BENDING WALL REINF. WITH EACH END LAP TO BE 24\"/>

TYP. INTERSECTING WALLS

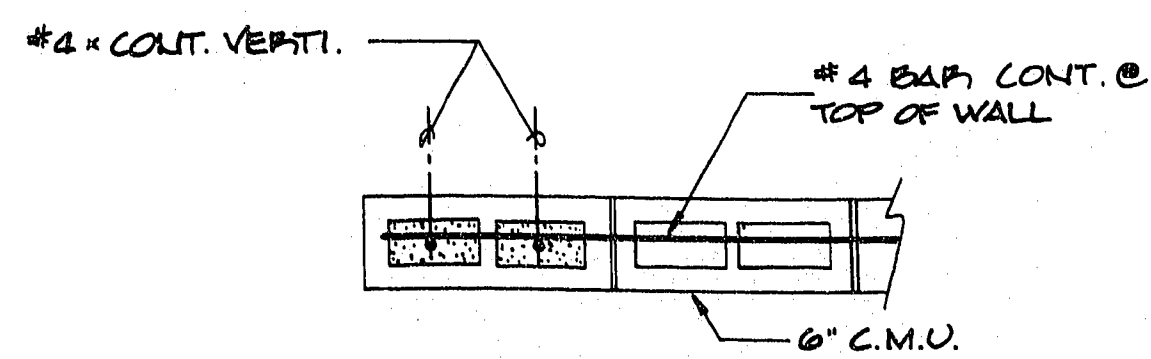

TYP. JAMB OR WALL END

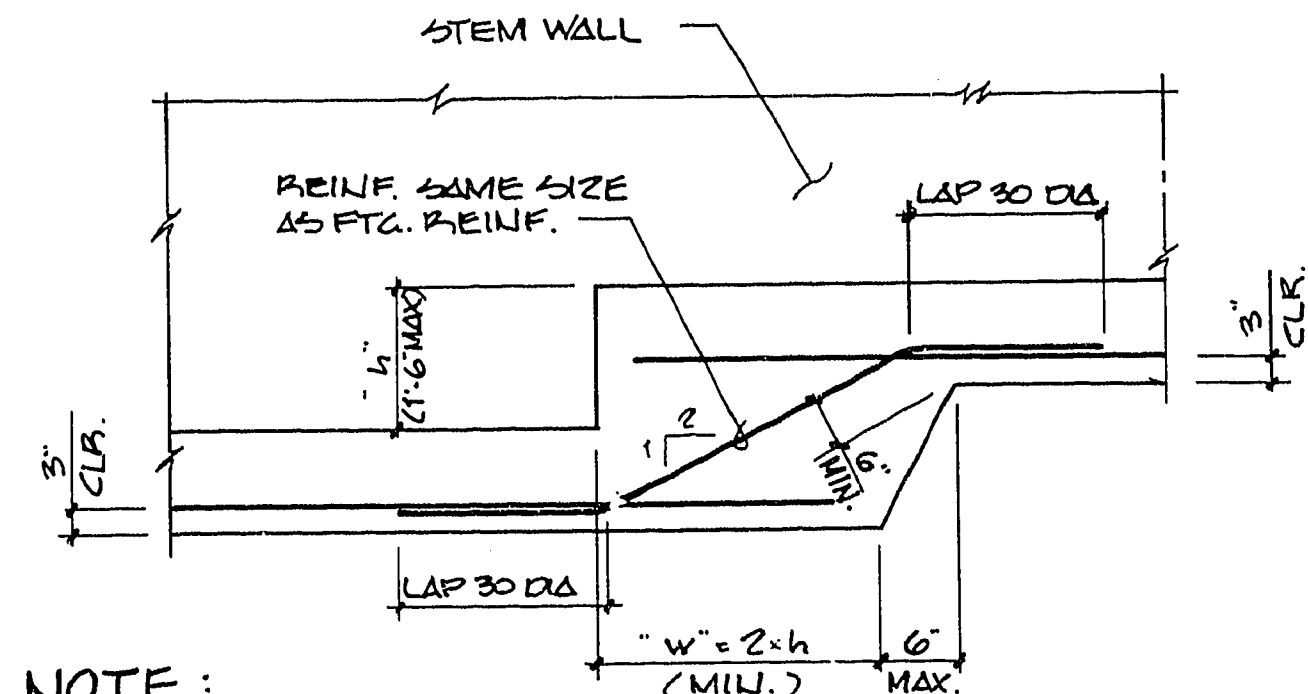

NOTE:

WHERE SPLICES OF DIFFERENT SIZE BARS OCCUR, LAP IS BASED ON LARGER DIAMETER. WHERE REINF. CHANGES AT STEPPED FTG. USE GREATER REINF. AT SPLICE BARS

TYPICAL STEPPED FOOTING

(SINGLE STEP)

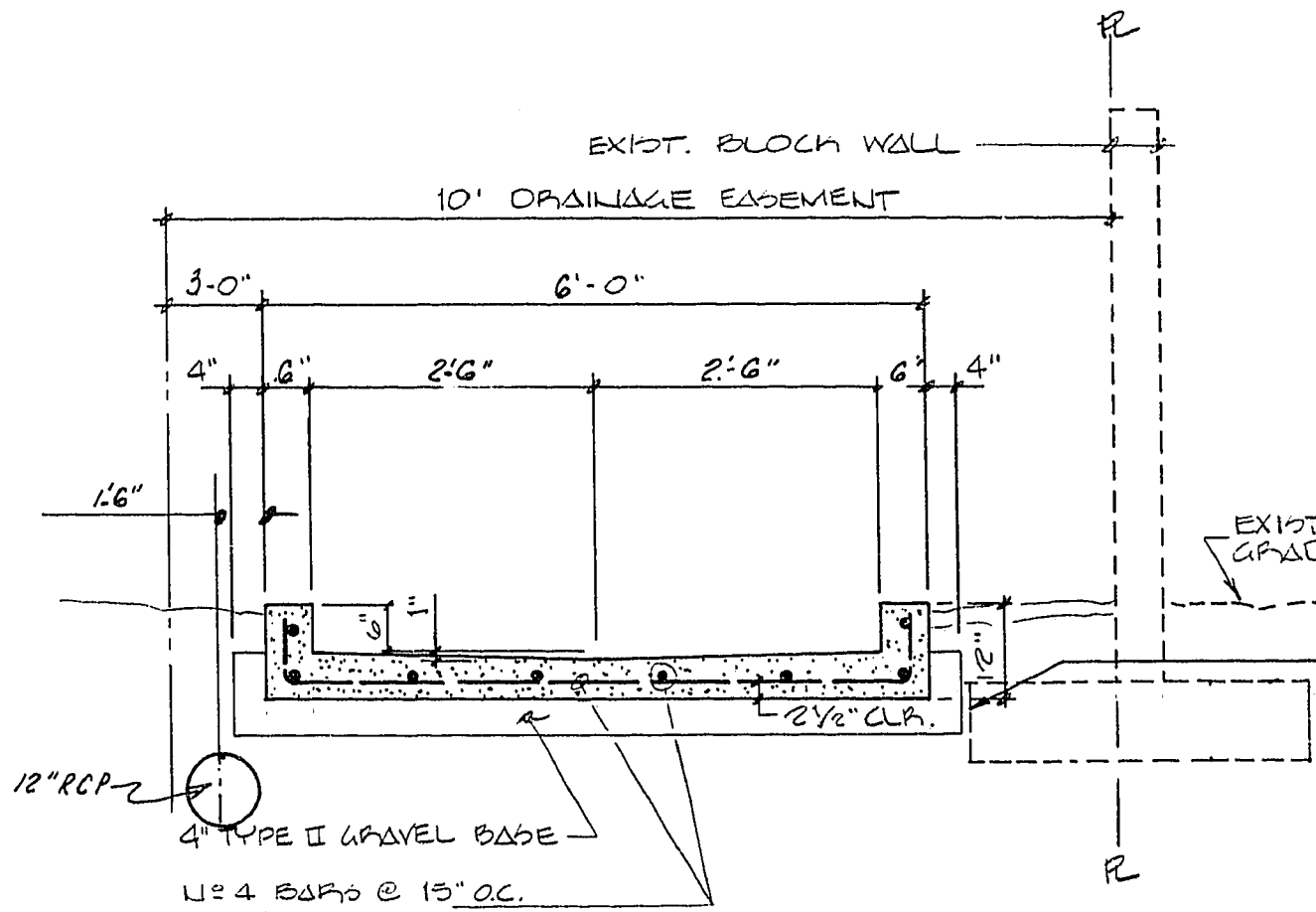

CONC. DRAINAGE CHANNEL DETAIL 2

SECTION A
NOT TO SCALE

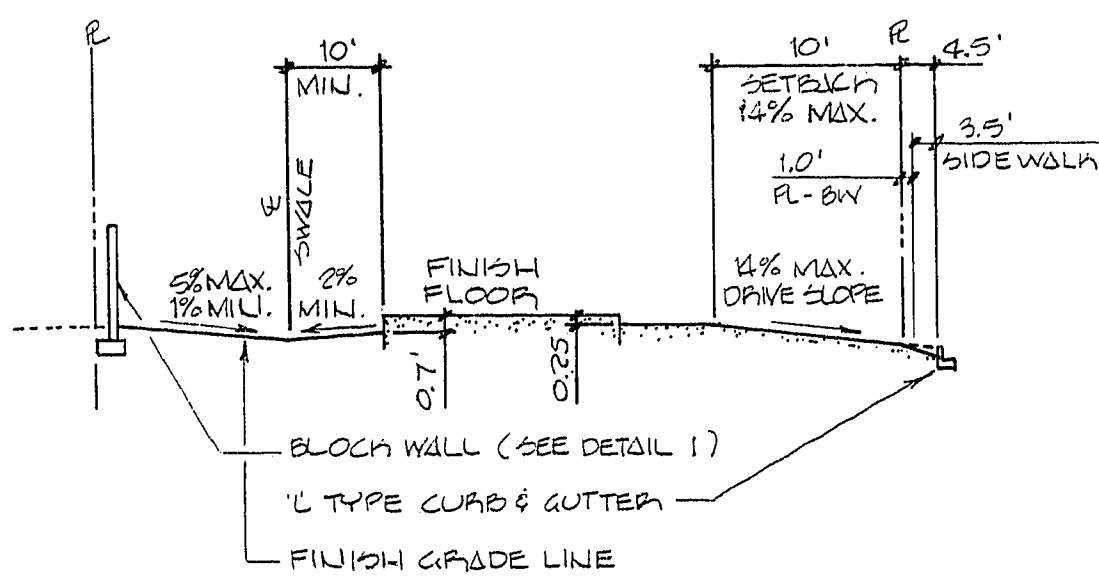

TYPICAL LOT SECTION B

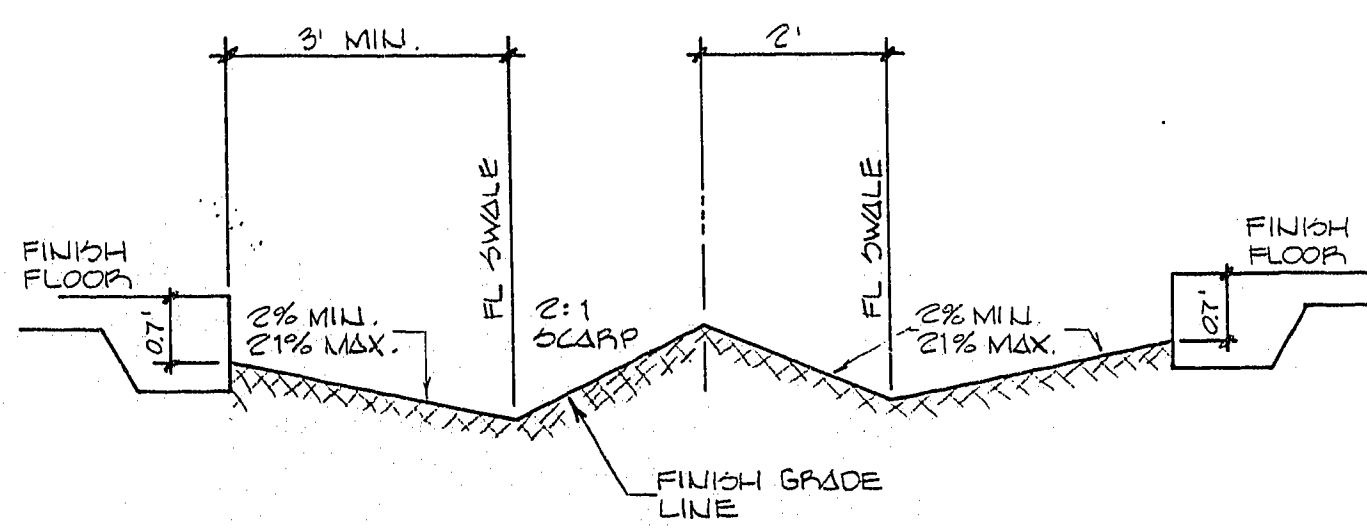

TYPICAL SIDE YARD SECTION WITH SCARP

SECTION C
NO SCALE

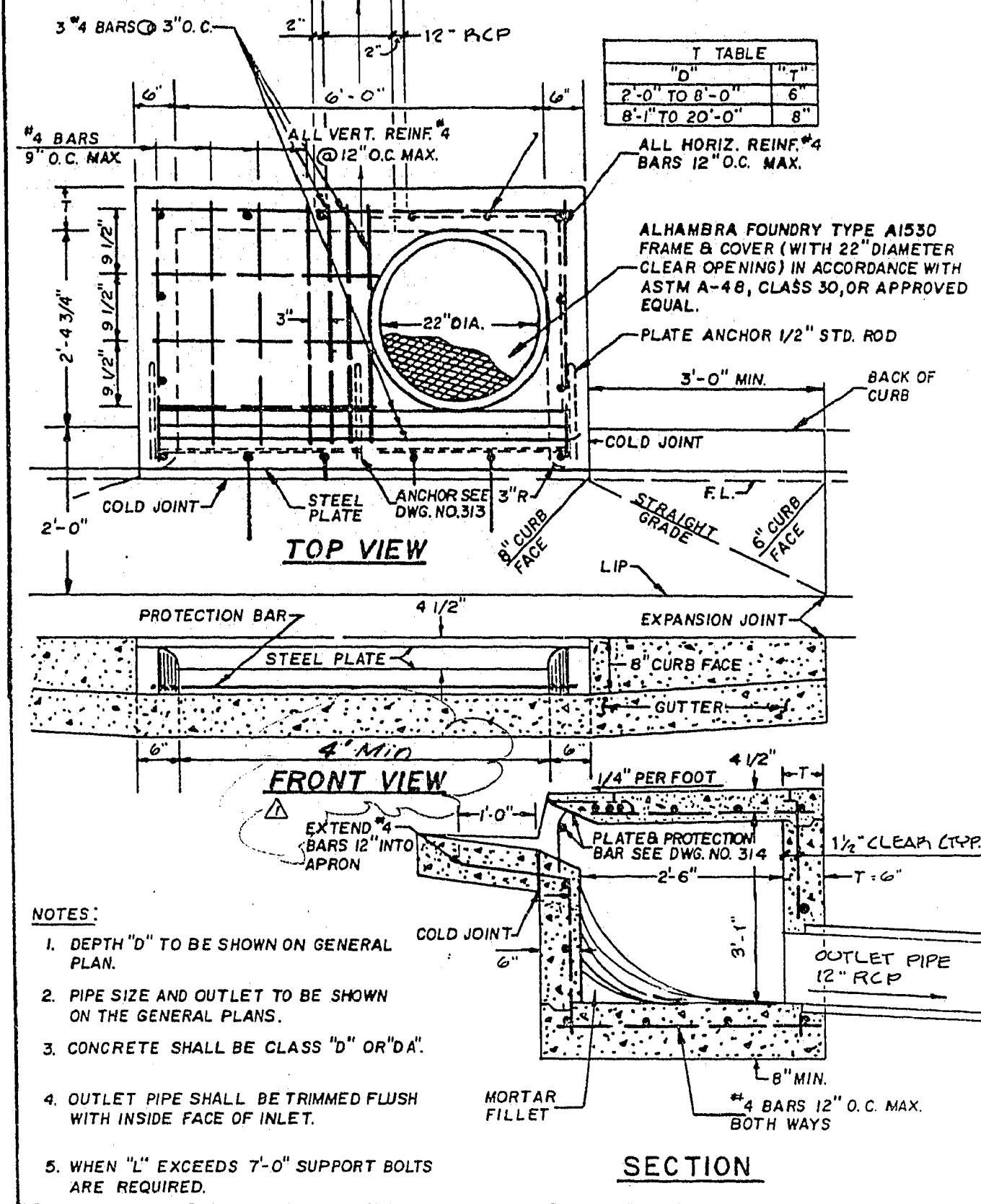

TYPE 'A' DROP INLET PER STD DWG 309

DETAIL 3
NO SCALE

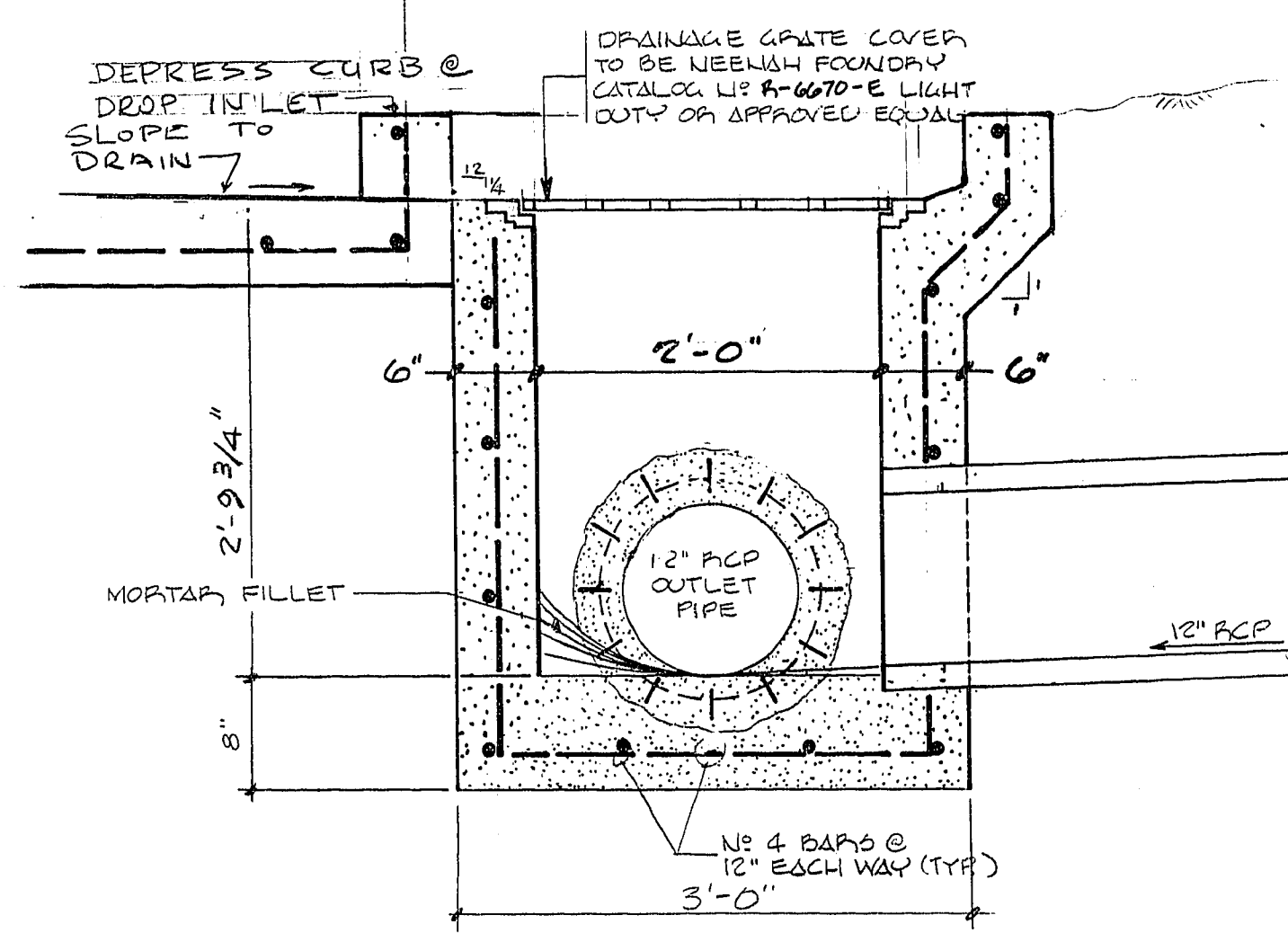

SECTION D
SCALE: 1/2\"/>

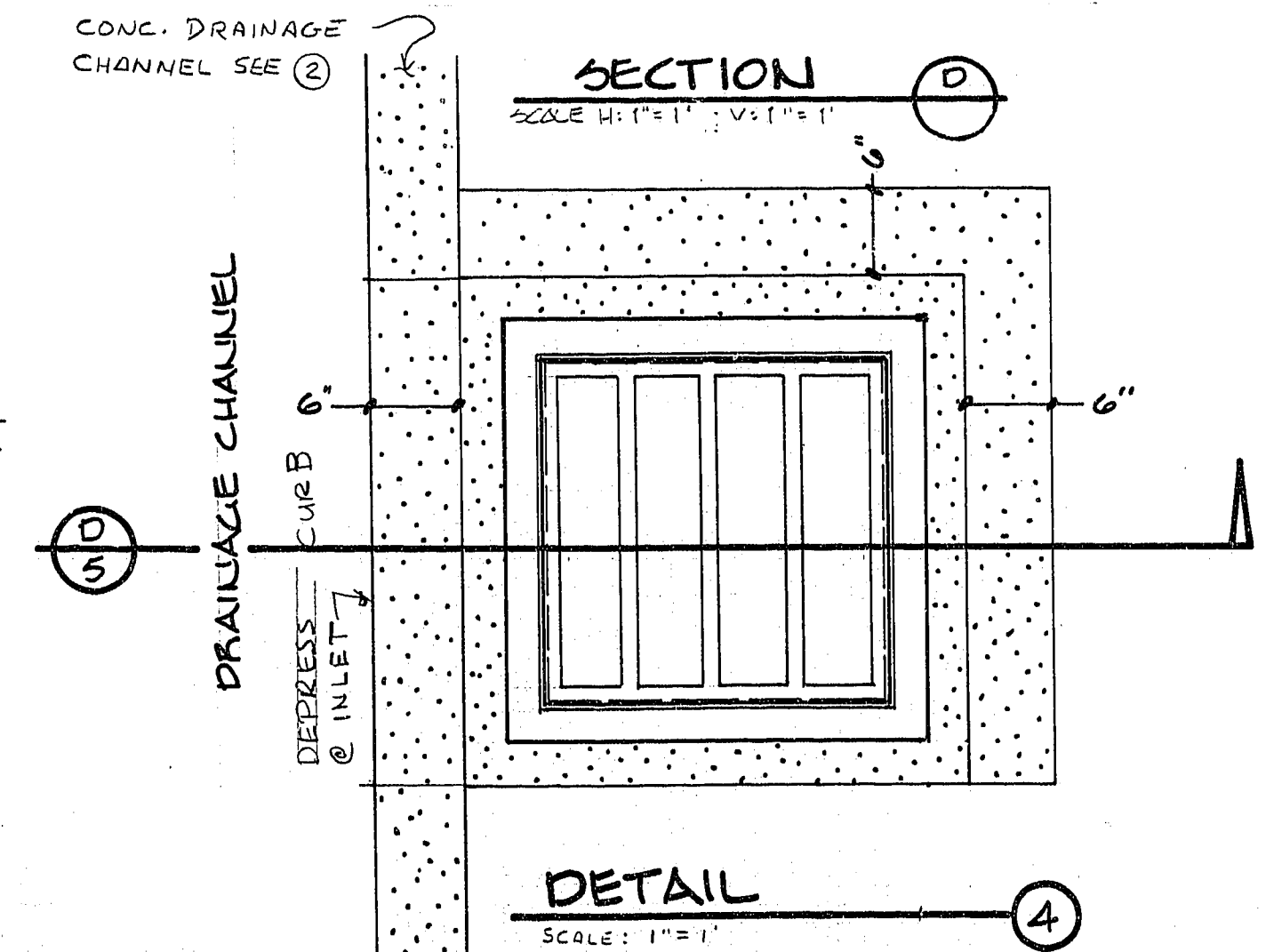

DETAIL 4
SCALE: 1\"/>

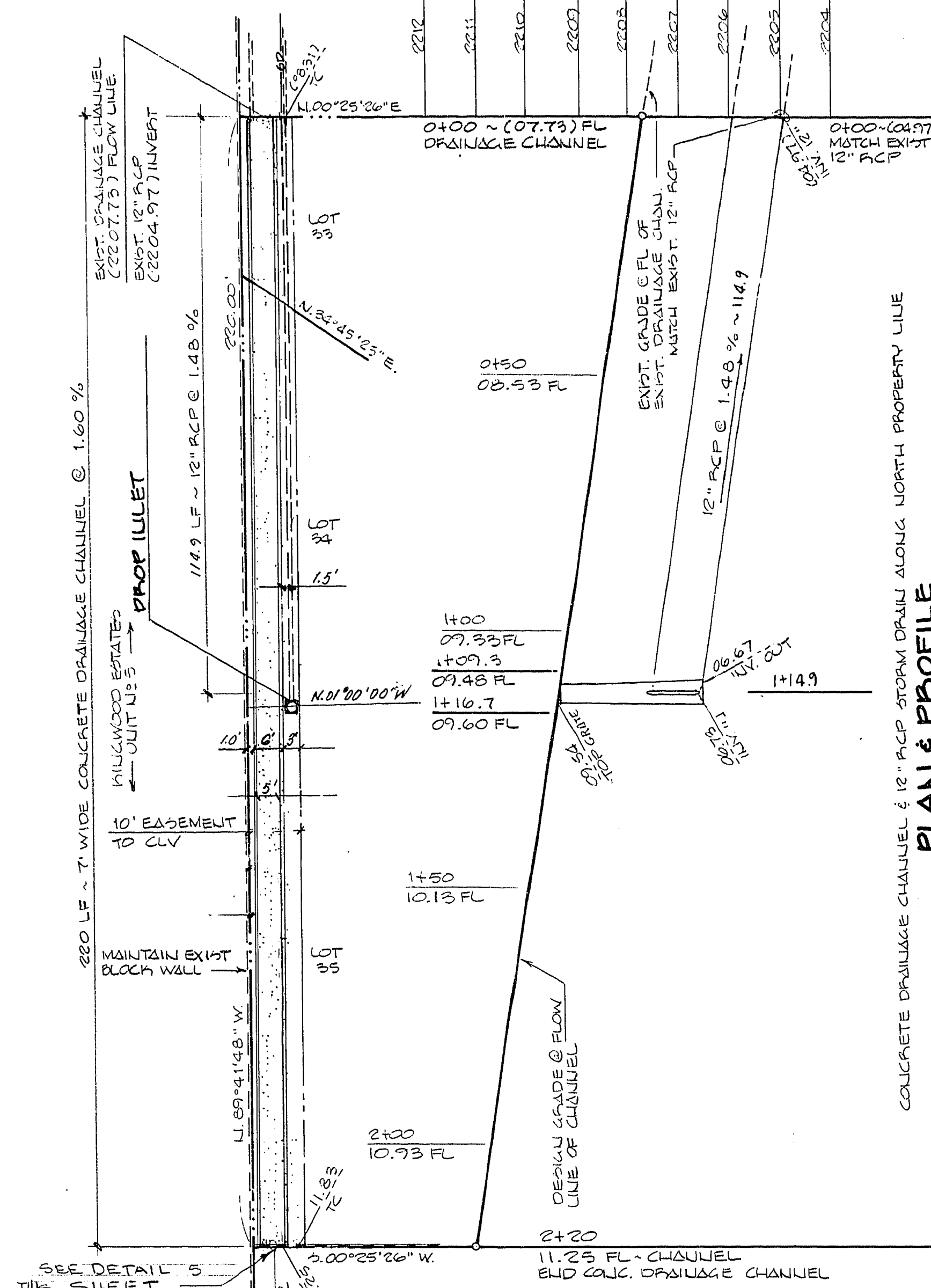

PLAN & PROFILE
SCALE: HORIZ. 1\"/>

ESTIMATED QUANTITIES

ITEM	QUANTITY
30\"/>	4 LF
12\"/>	180 LF
DROP INLET TYPE 'A'	1 EA
7\"/>	220 LF

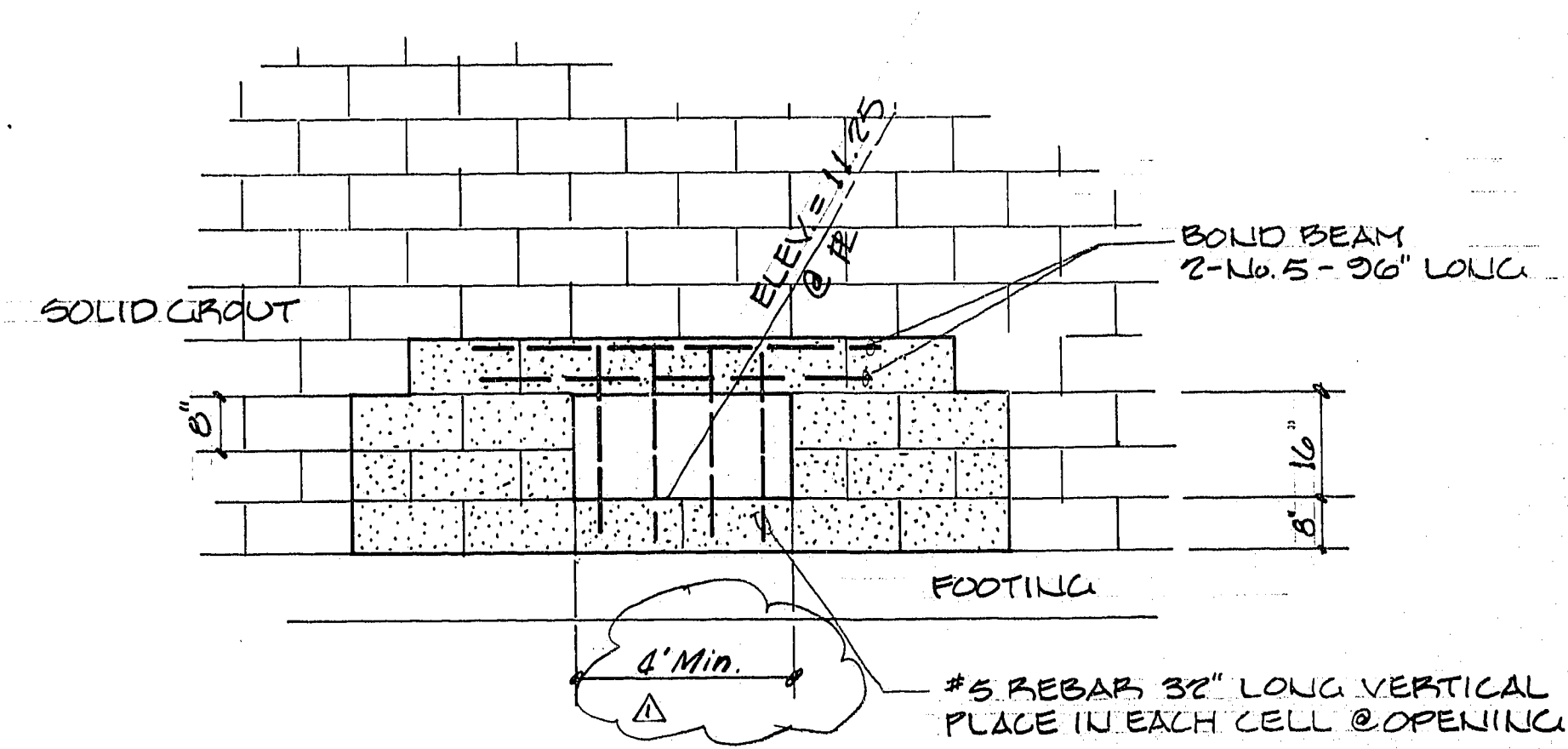

DETAIL 5 - OPENING THRU BLOCKWALL

APPROVALS

CLV CHIEF LAND DEVELOPMENT

9.20.85 DATE

APPROVED: [Signature]

DATE: 9/20/85

REVISIONS: [Table]

PREPARED FOR: [Client Name]

DESIGN: [Firm Name]

DRAWN: [Firm Name]

CHECK: [Firm Name]

SCALE: AS SHOWN

BAUGHMAN & TURNER
MINING ENGINEERS
LAND SURVEYORS
3235 WEST CHARLESTON BOULEVARD
LAS VEGAS, NEVADA 89102
702-792-8771

DESERT PARK HOMES - UNIT N-2

SECTION 28, TOWNSHIP 20 SOUTH, RANGE 60 EAST, MDB&M, NEVADA, CITY OF LAS VEGAS, CLAY COUNTY, NV

PROJ. NO. 100-100-100-100

SHEET 100-100-100-100

FB155 P89