

Call before you Dig
1-800-227-2600
Call before you Overhead
1-702-593-6111

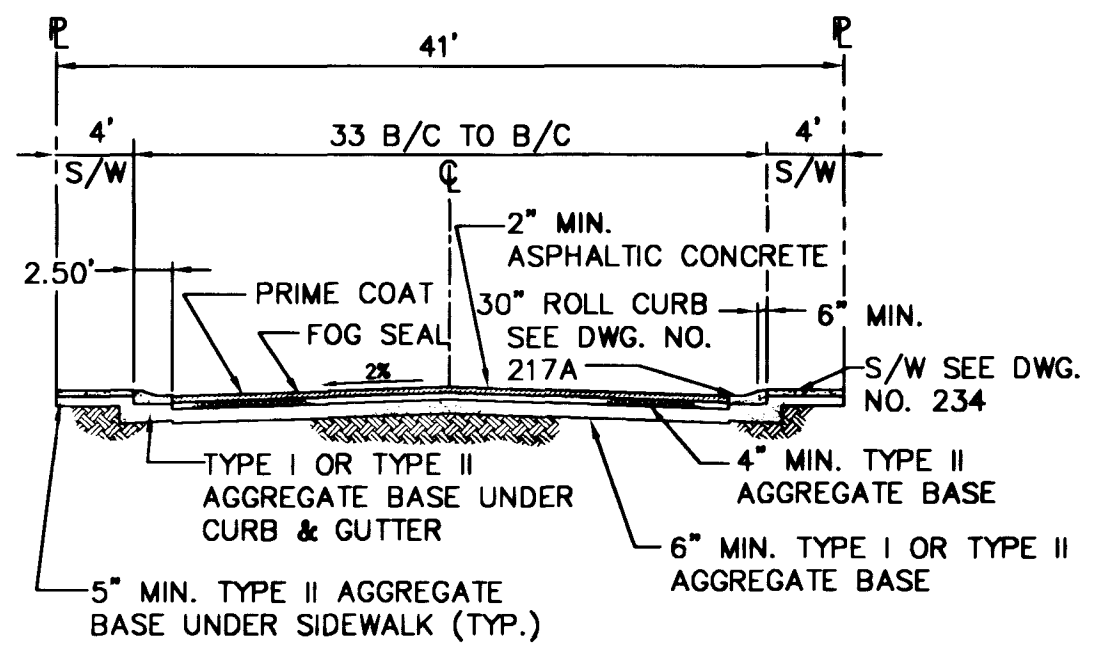

1 41' PRIVATE RESIDENTIAL DRIVE
NOT TO SCALE

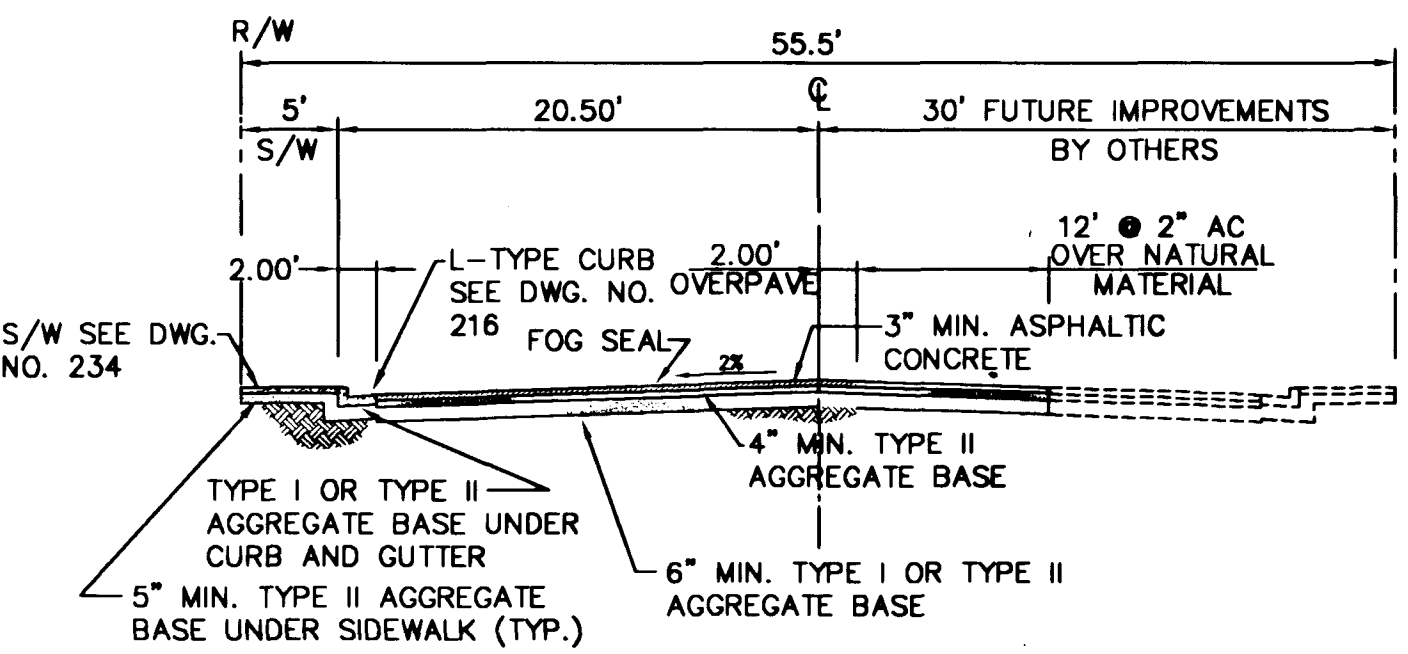

2 55.5' HALF STREET SECTION
NOT TO SCALE
LEON AVENUE

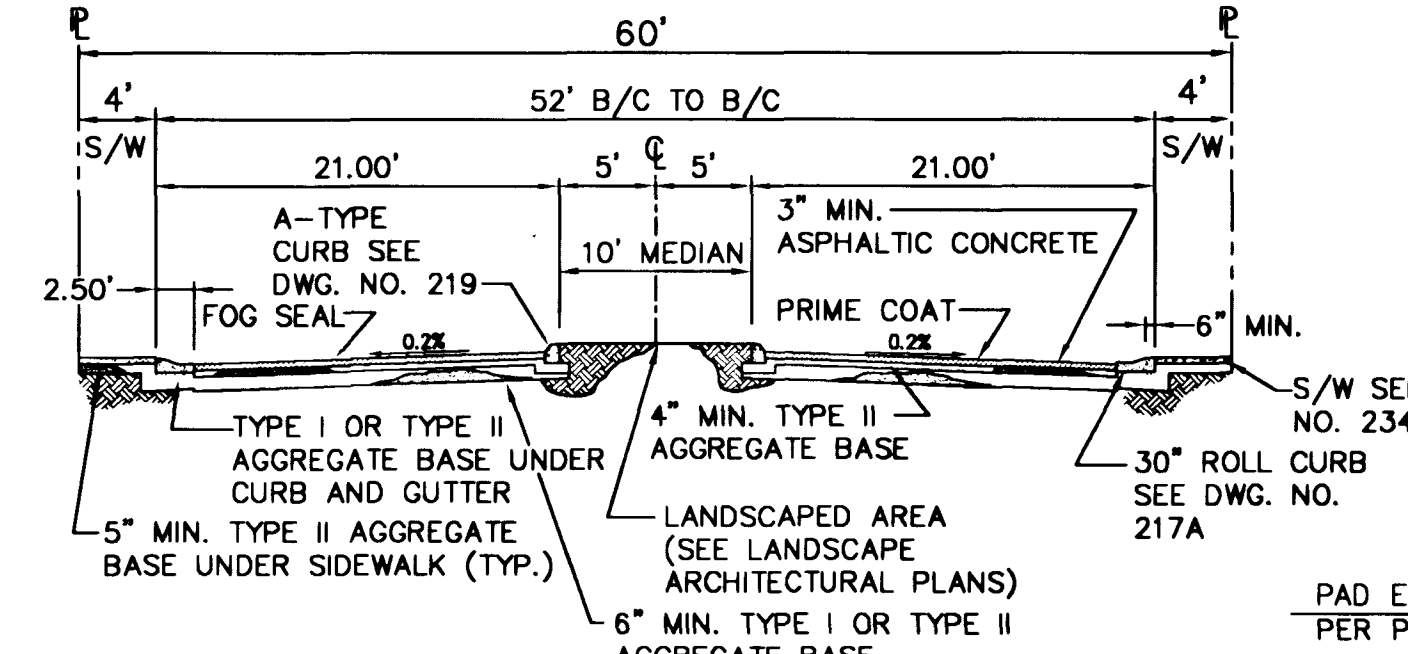

3 60' PRIVATE DRIVE SECTION
NOT TO SCALE

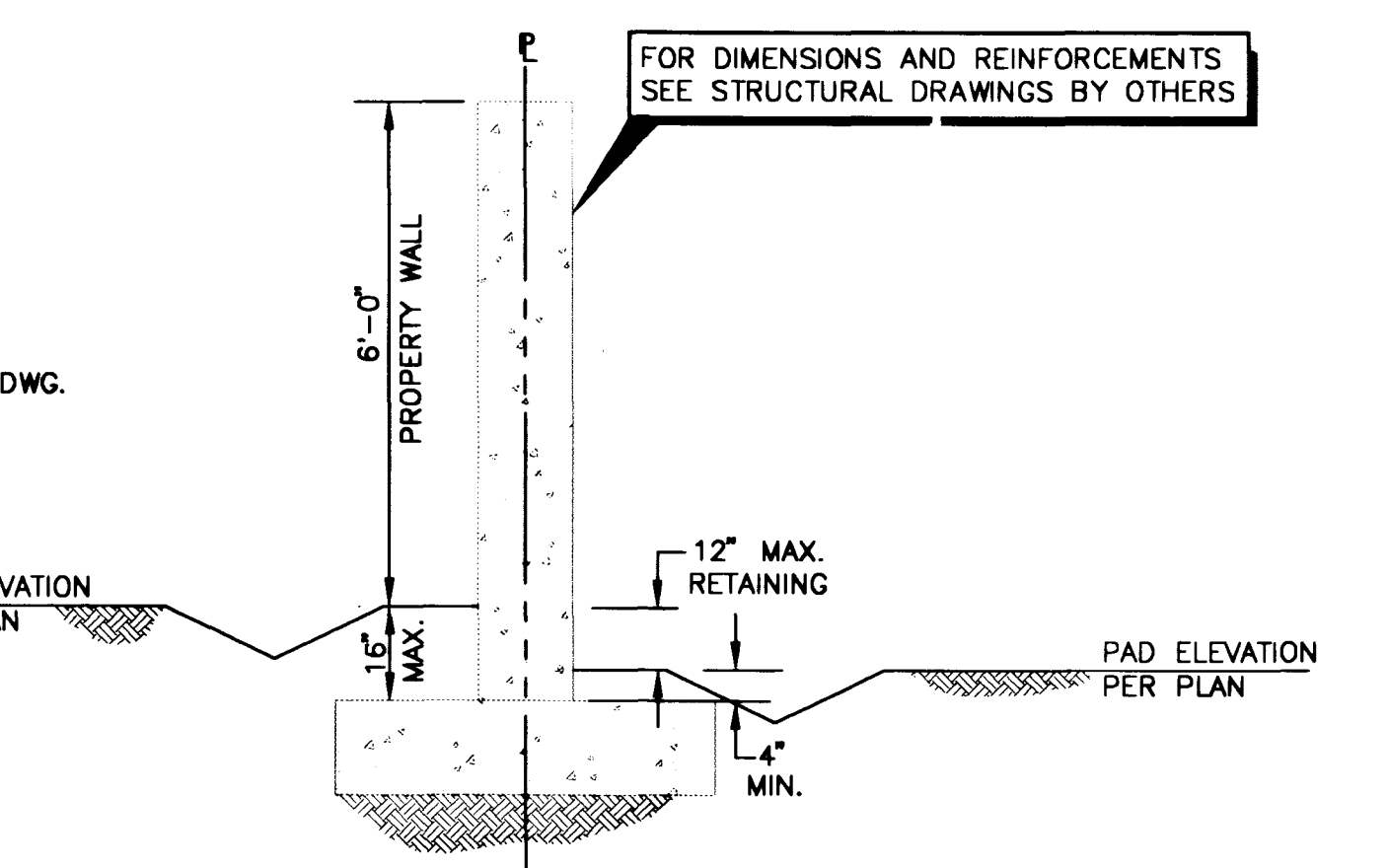

A SECTION A
NOT TO SCALE

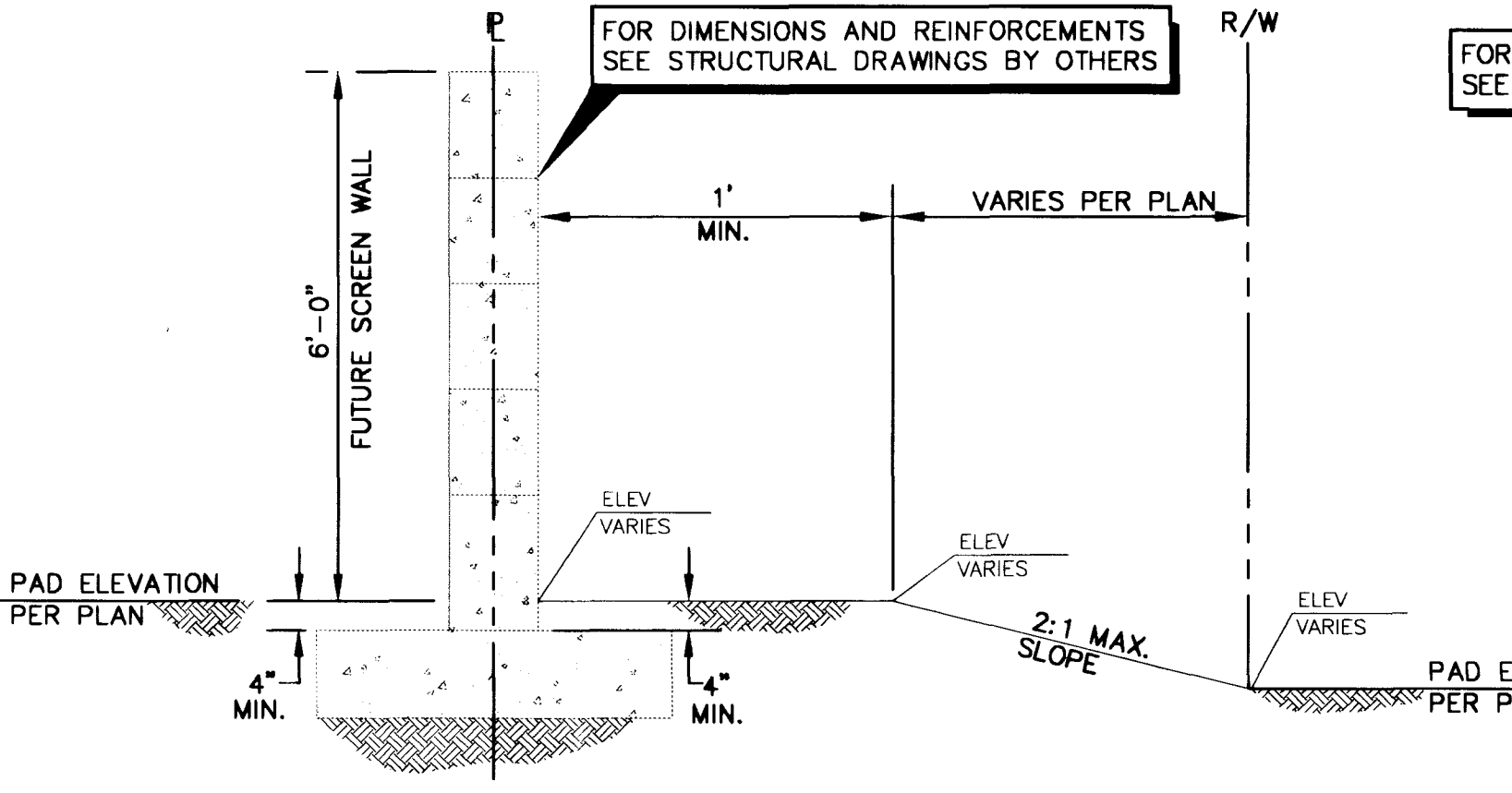

B SECTION B
NOT TO SCALE

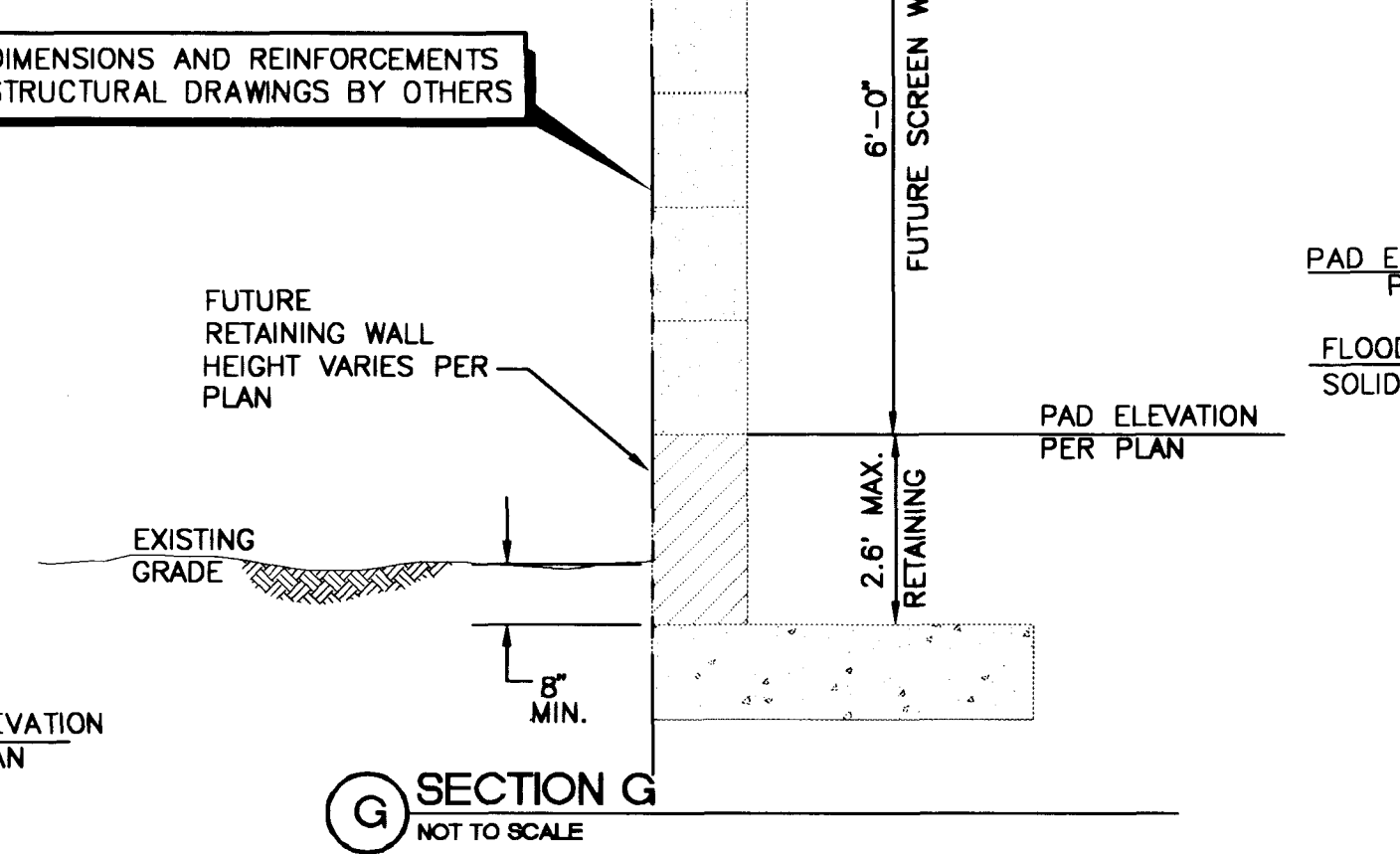

G SECTION G
NOT TO SCALE

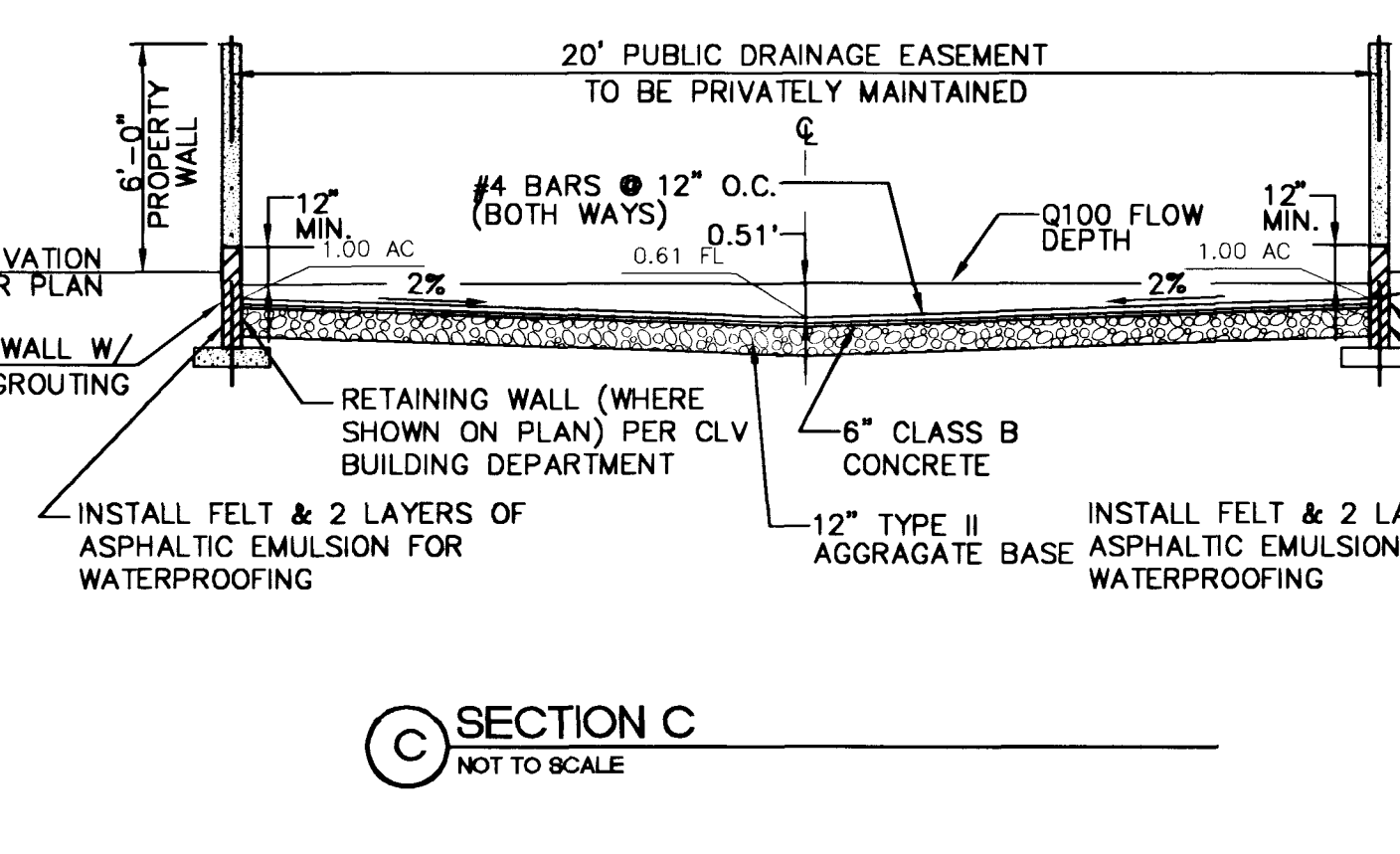

C SECTION C
NOT TO SCALE

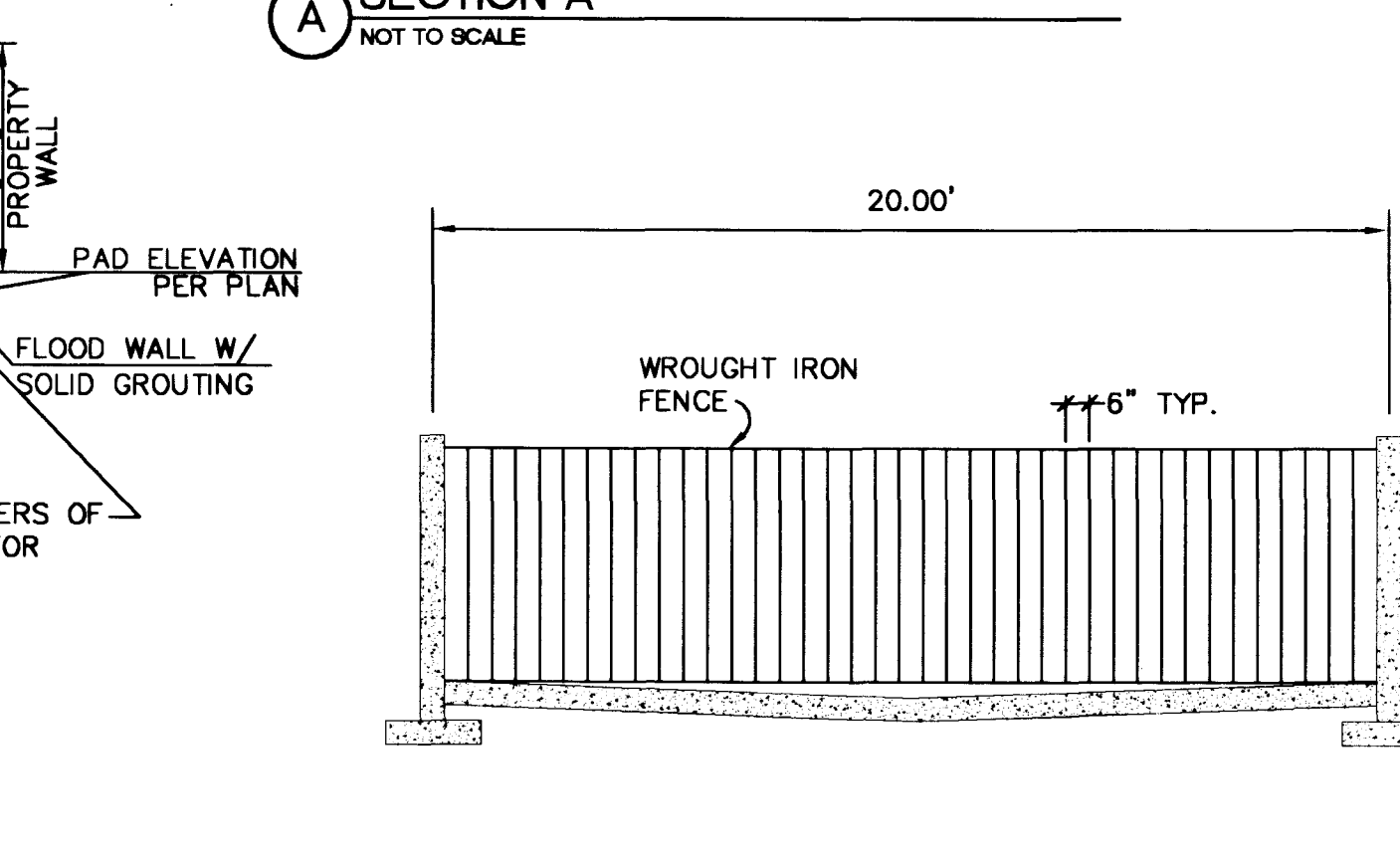

D WROUGHT IRON FENCE DETAIL
NOT TO SCALE

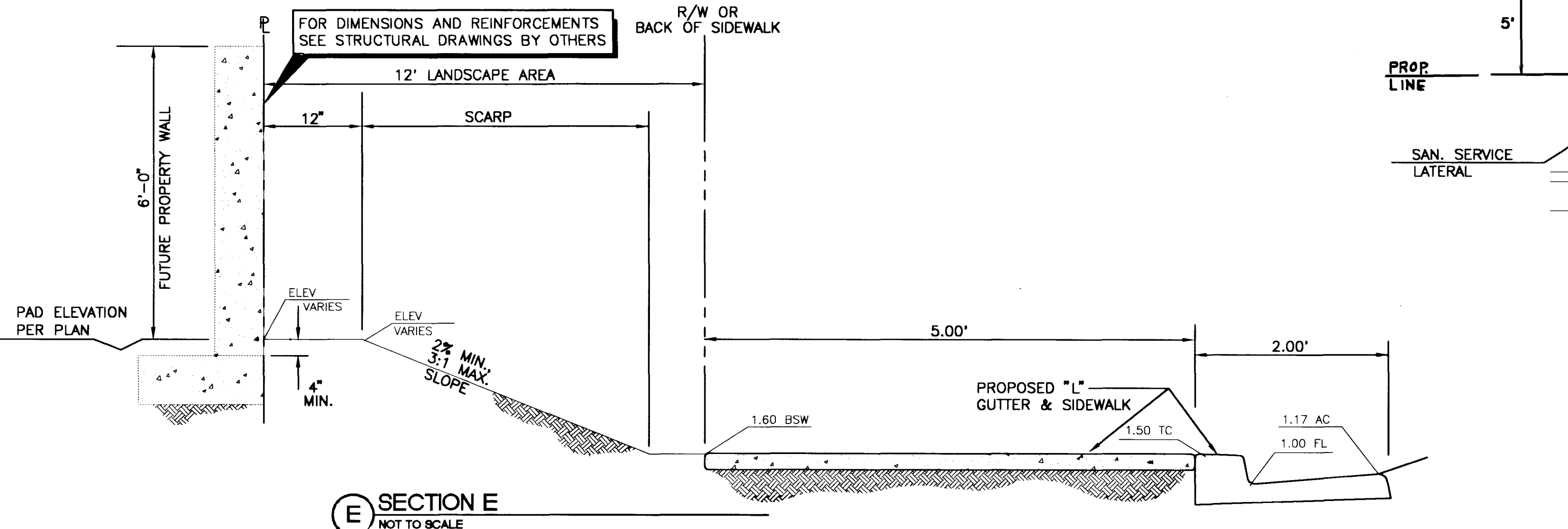

E SECTION E
NOT TO SCALE

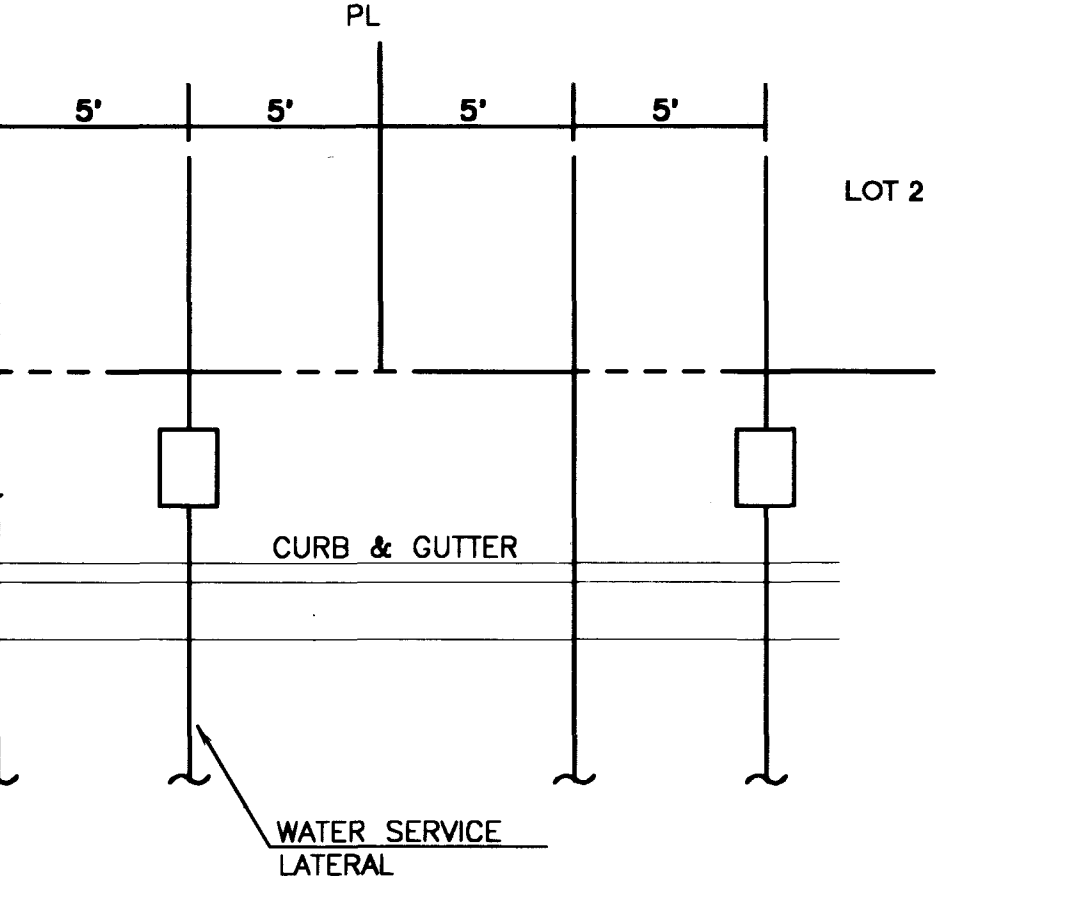

J TYPICAL UTILITY SERVICE LAYOUT
NOT TO SCALE

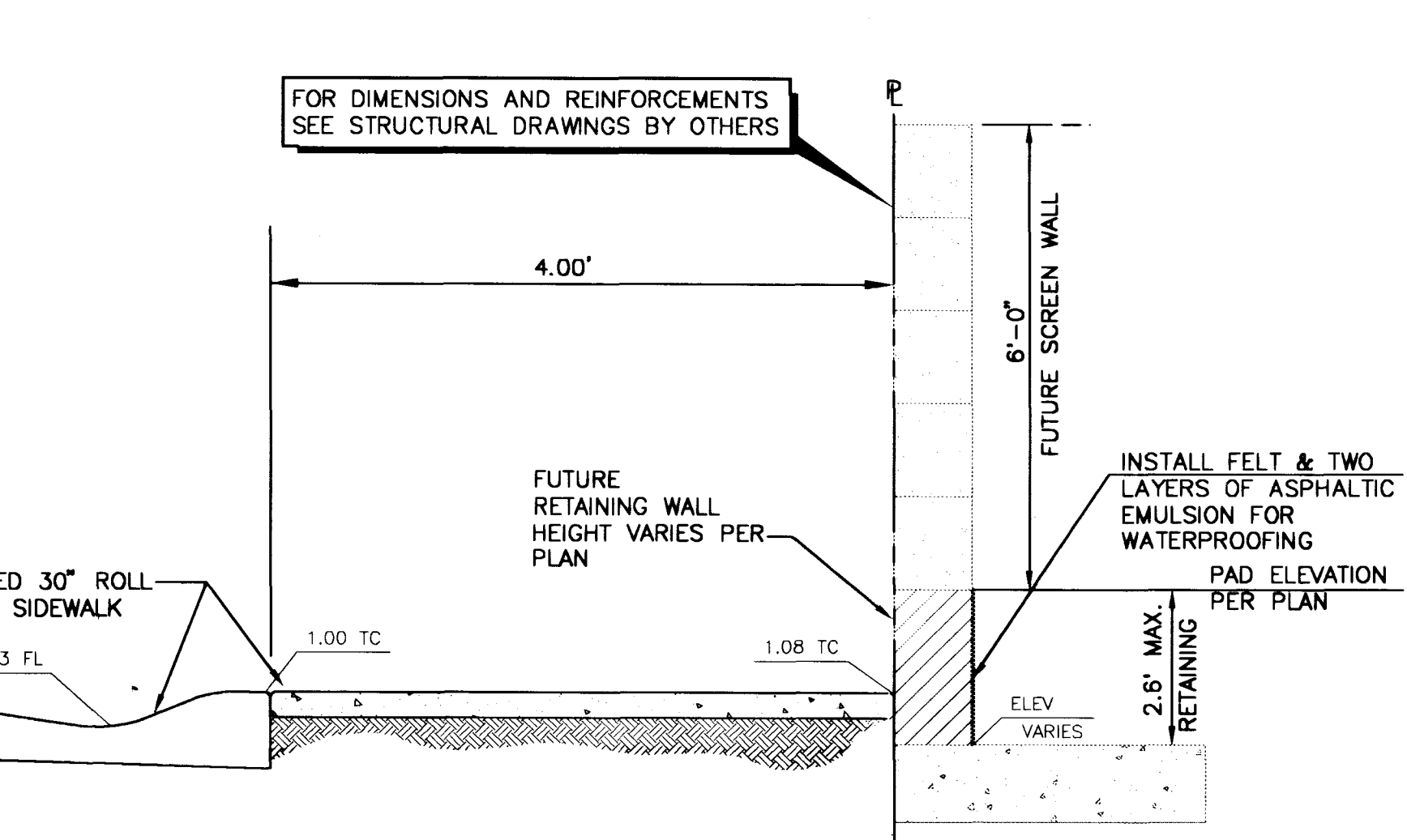

H SECTION H
SCALE: 1/2\"/>

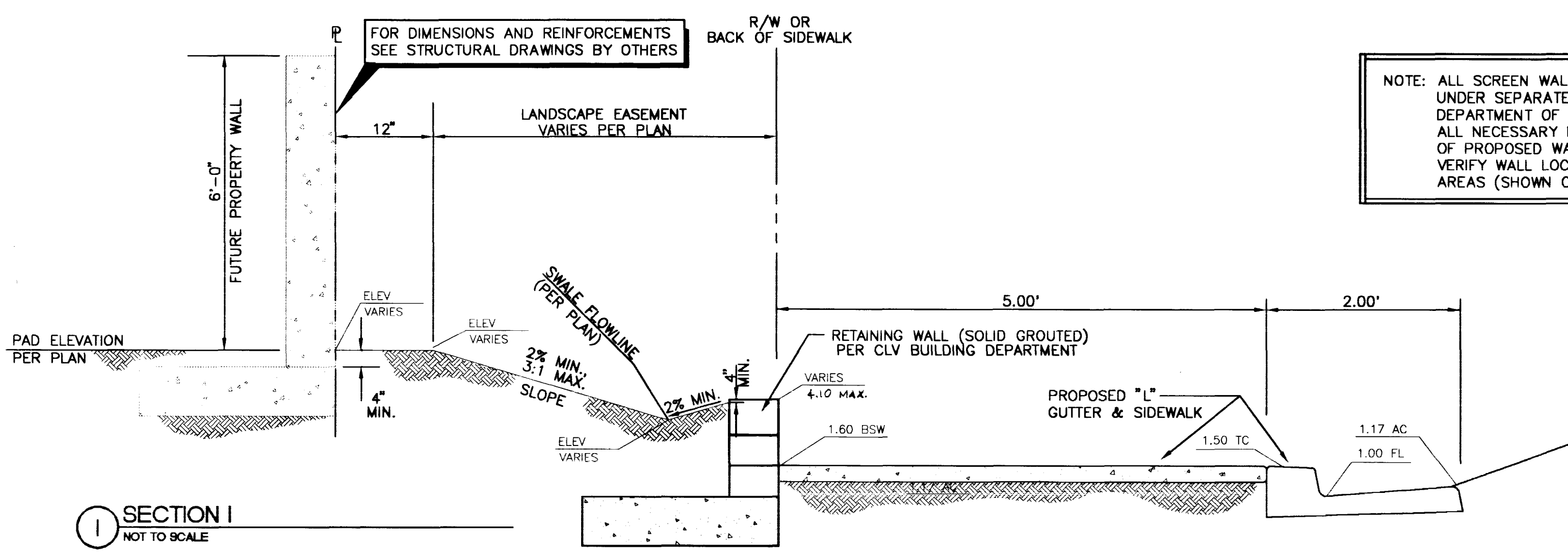

I SECTION I
NOT TO SCALE

NOTE: ALL SCREEN WALLS AND RETAINING WALLS ARE UNDER SEPARATE PERMITS FROM CLARK COUNTY DEPARTMENT OF BUILDING. CONTRACTOR TO OBTAIN ALL NECESSARY PERMITS PRIOR TO CONSTRUCTION OF PROPOSED WALLS. CONTRACTOR SHOULD ALSO VERIFY WALL LOCATIONS WITHIN SITE DISTANCE AREAS (SHOWN ON FINAL MAP)

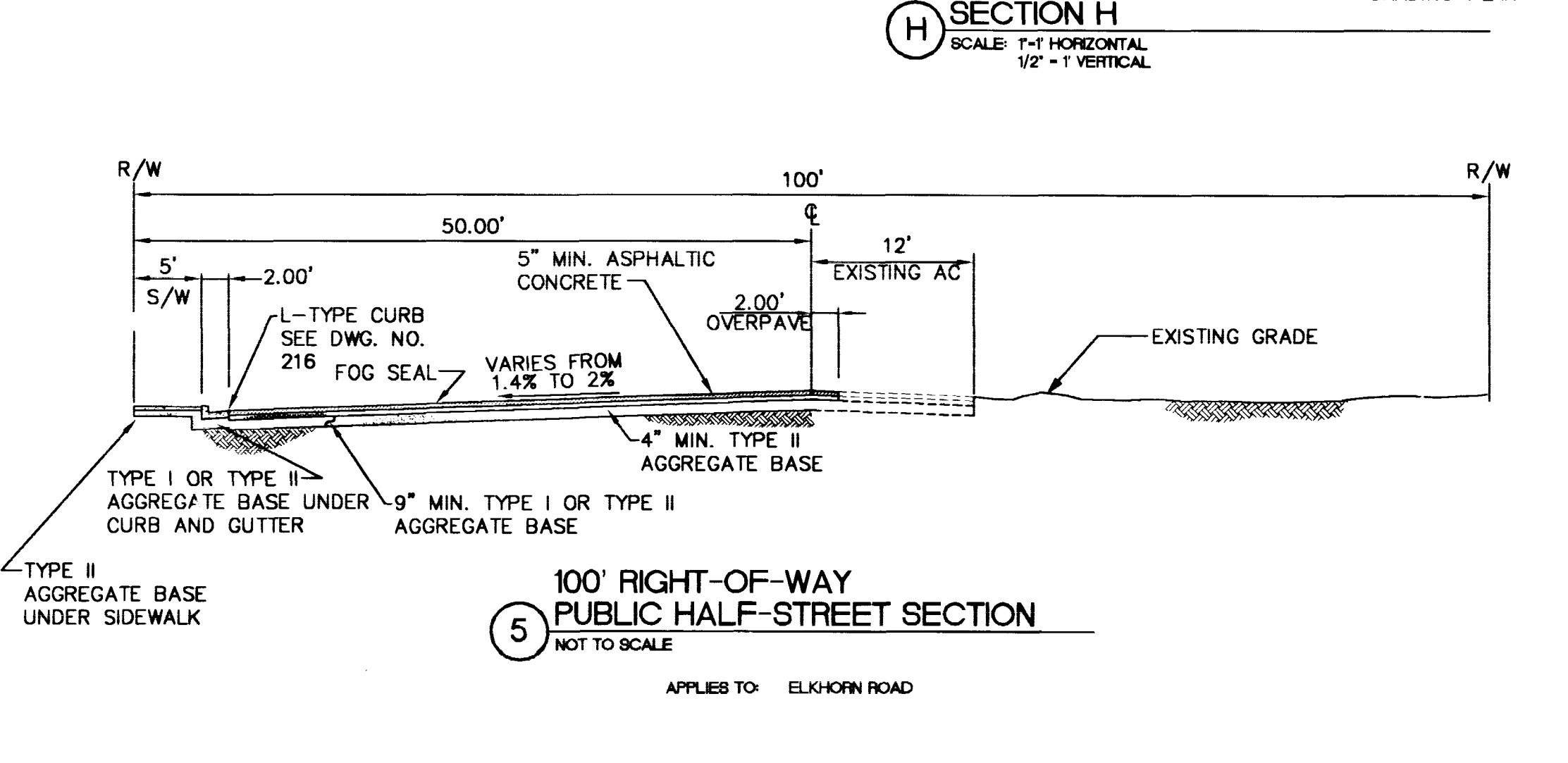

5 100' RIGHT-OF-WAY PUBLIC HALF-STREET SECTION
NOT TO SCALE
APPLIES TO: ELKHORN ROAD

SCALE	AS NOTED	JOB No.	99-9005-03	PROJECT DATE:	07/26/99
DRAWN BY:	SSG/ahd	CHECKED BY:	SSG/JML	PROJECT DATE:	02/99
NO.	REVISION	DATE	APP.		
6					
5					
4					
3					
2					
CONCORDIA • ELKHORN/LEON					
CITY OF LAS VEGAS					
NEVADA					
DETAIL SHEET UNIT 1					
CONCORDIA					
H O M E S					
DEVELOPER					
CONCORDIA					
OF NEVADA					
LELAND JAMESON					
PROFESSIONAL ENGINEER					
SEAL					
6280 S. Valley View Blvd Suite 200 Las Vegas, NV 89118 Tel: (702) 368-0008 Fax: (702) 368-0047					
CVL CONSULTANTS, INC.					
ENGINEERING • PLANNING • LAND SURVEYING					
SHEET D1					
17 OF 17					
AGENCY DWG. NO. 1074-4619-1					

