

13 DRAINAGE EASEMENT SECTION
SCALE: NO SCALE

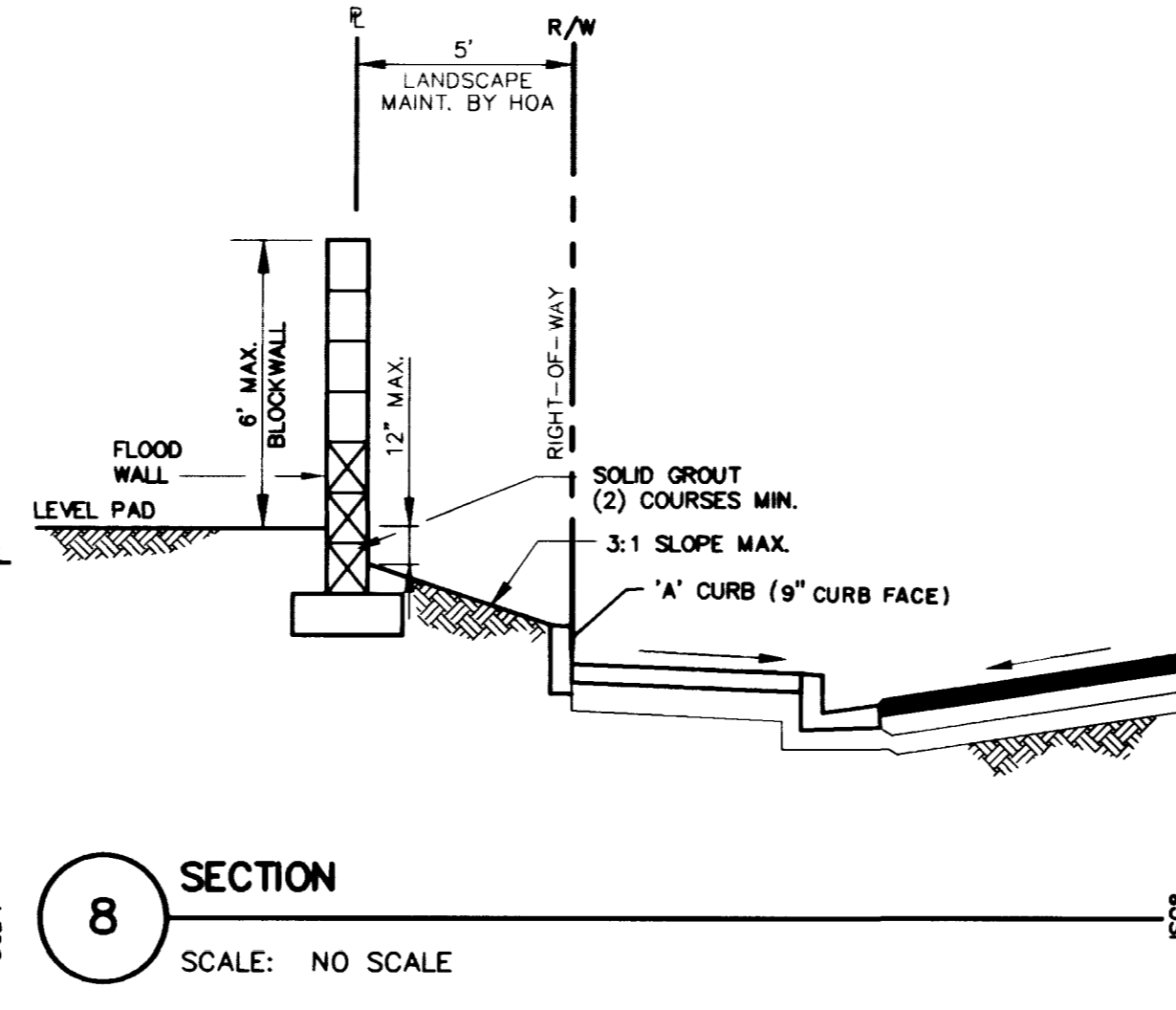

8 SECTION
SCALE: NO SCALE

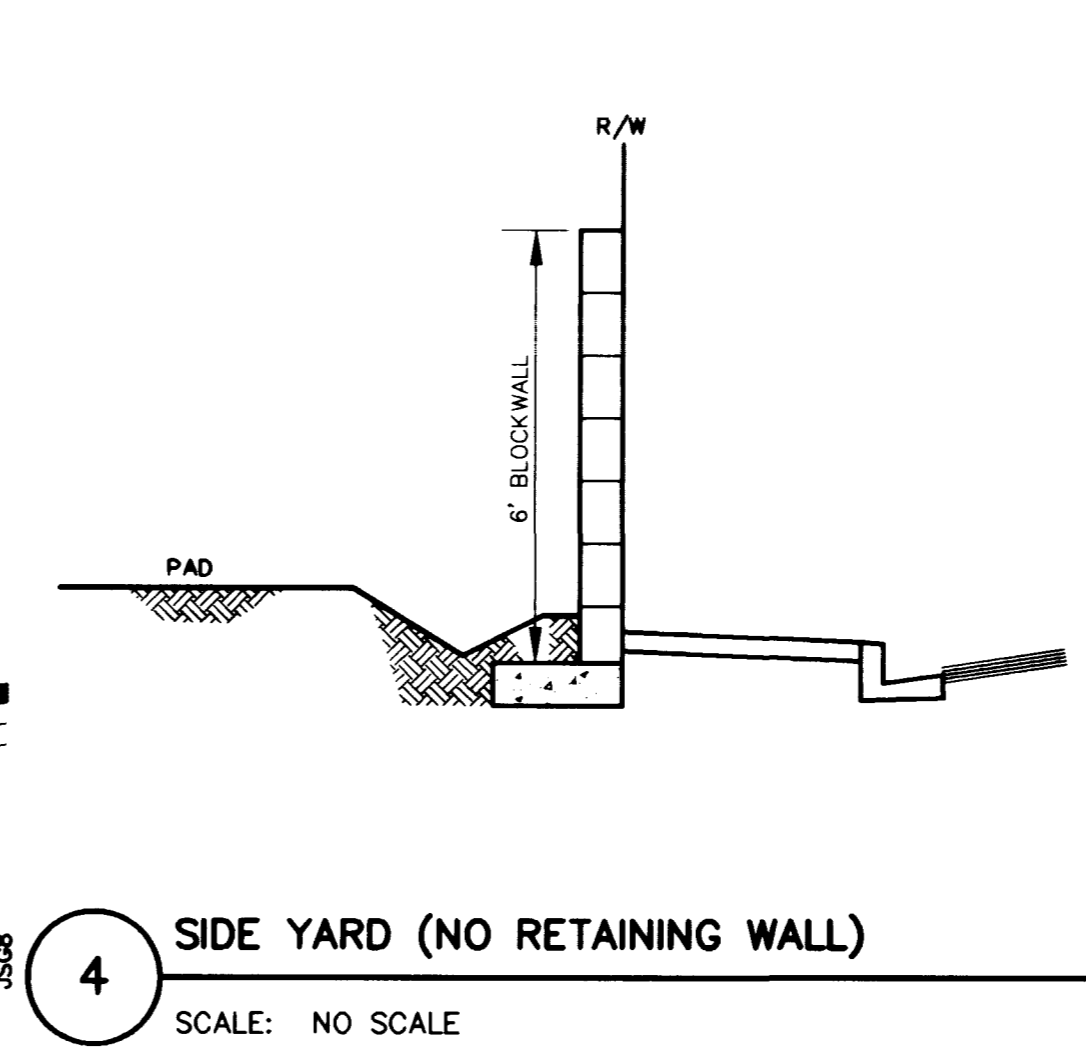

4 SIDE YARD (NO RETAINING WALL)
SCALE: NO SCALE

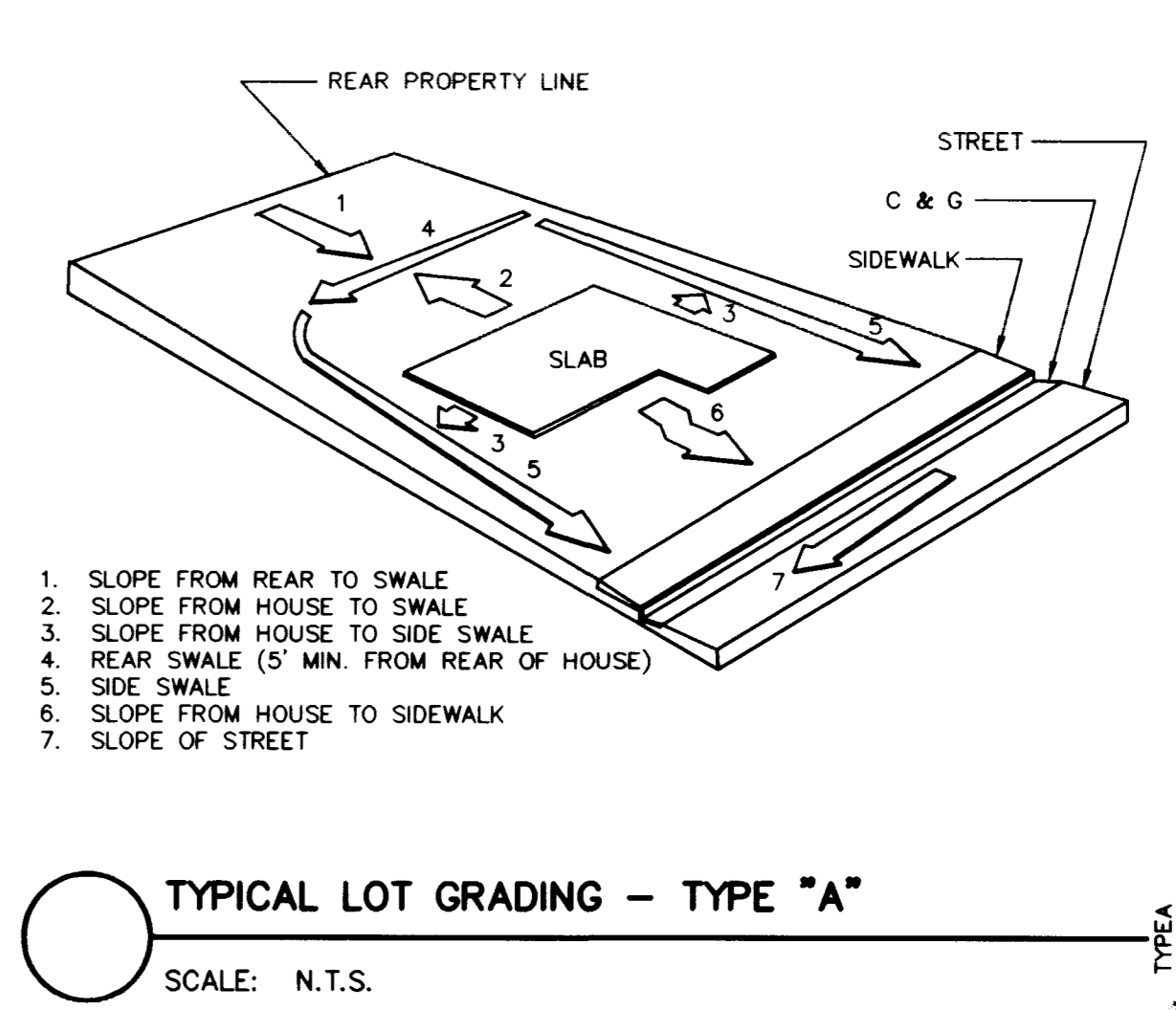

TYPICAL LOT GRADING - TYPE "A"
SCALE: N.T.S.

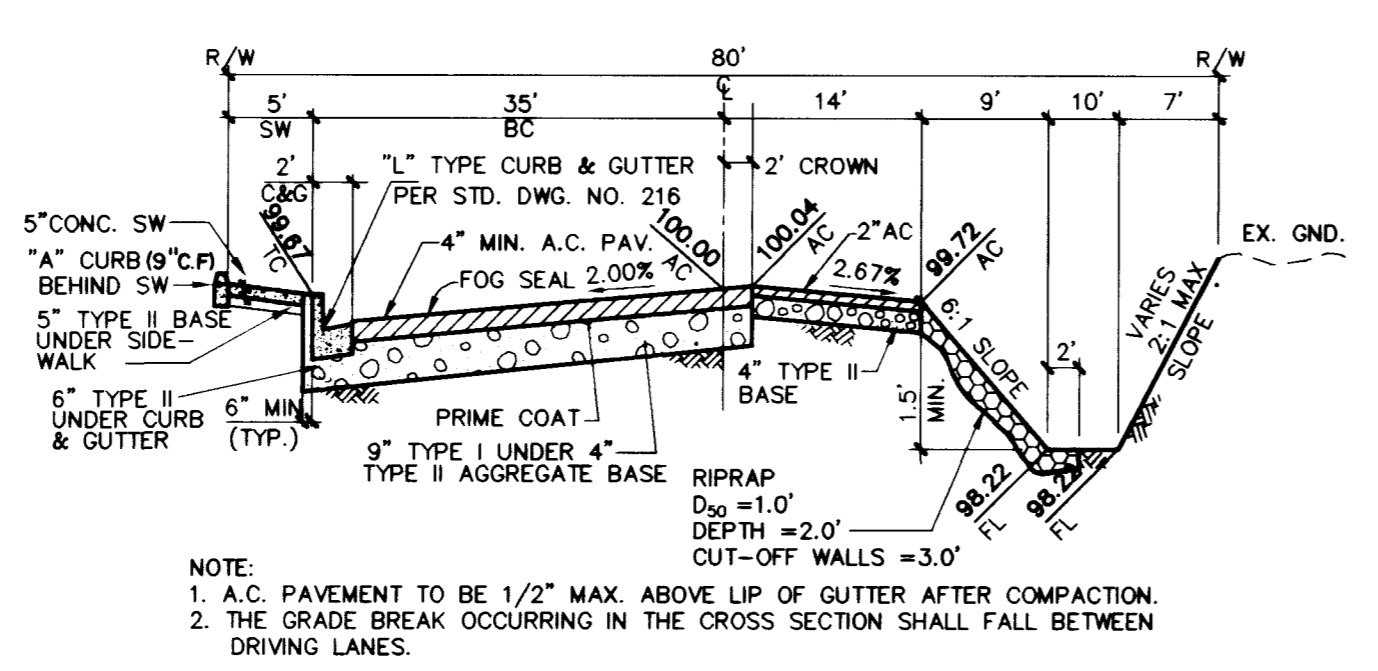

15 TYPICAL STREET SECTION (DEER SPRINGS WAY)
SCALE: NO SCALE

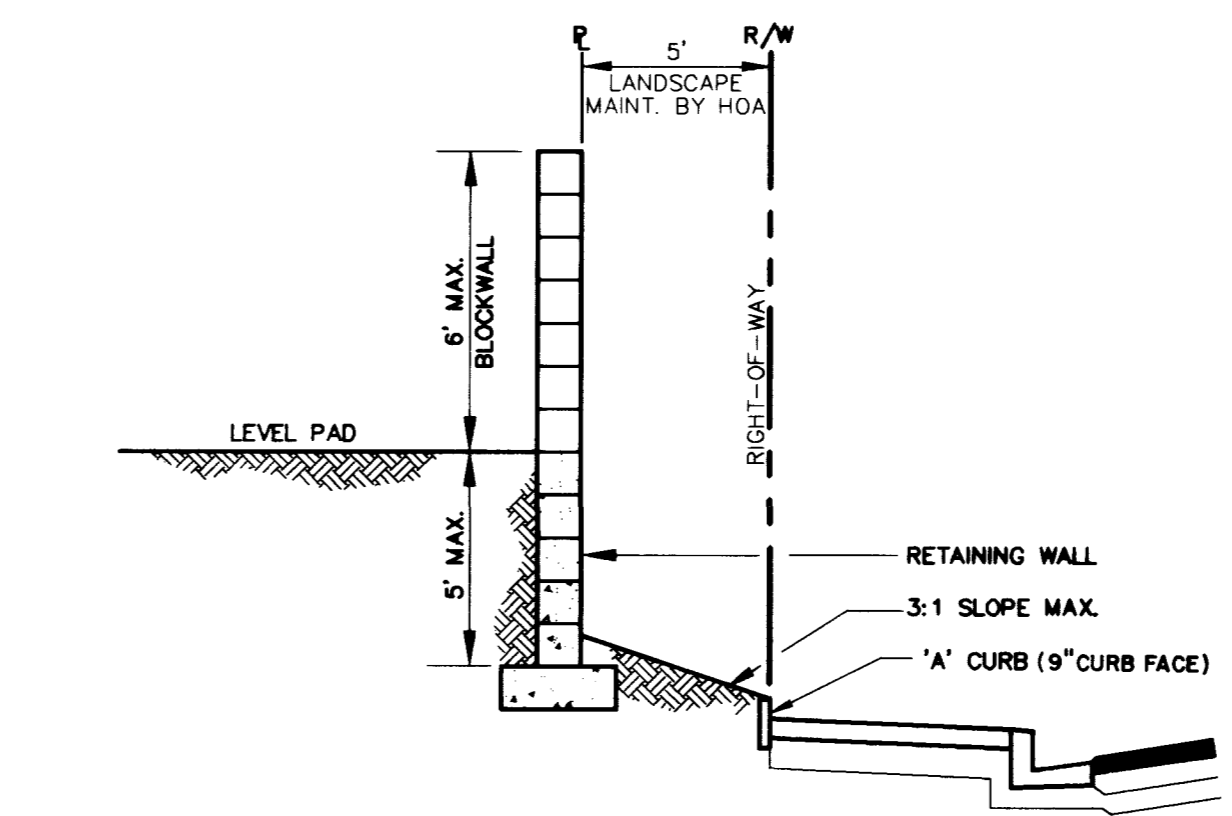

5 SECTION
SCALE: NO SCALE

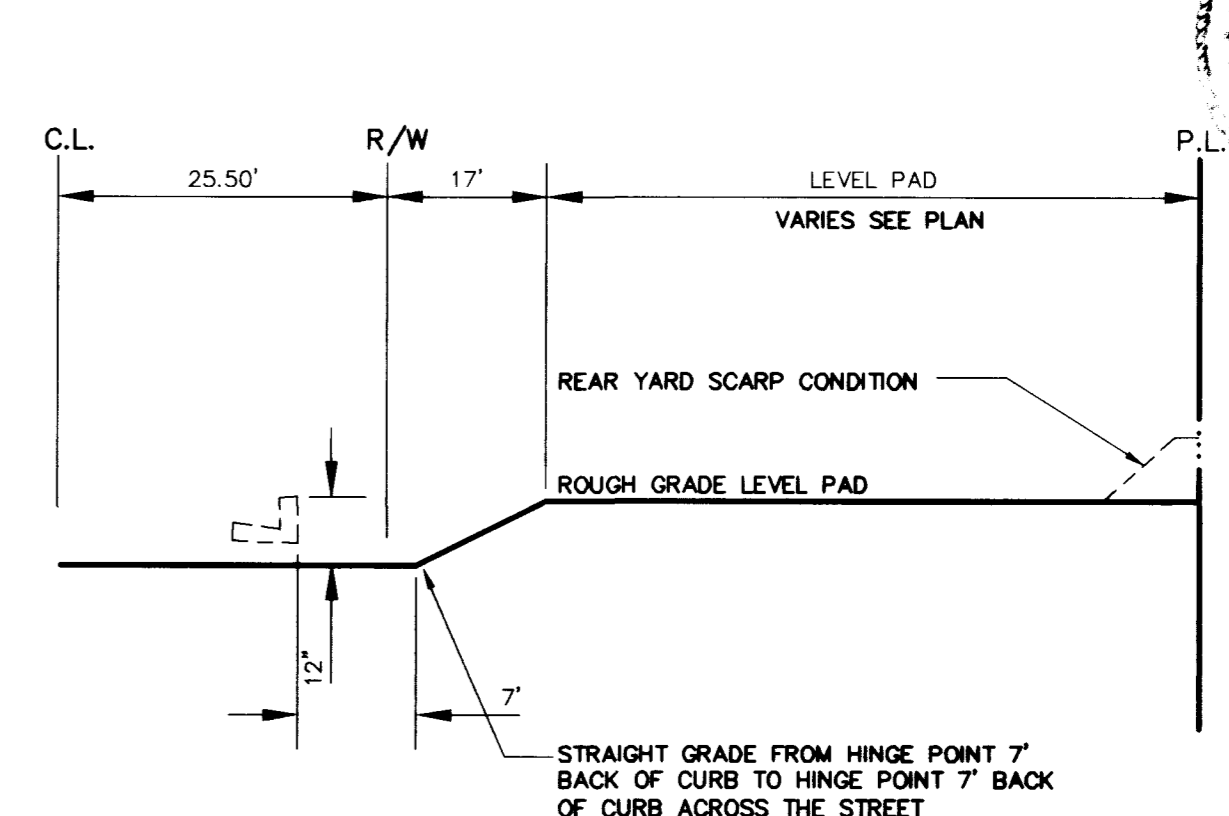

1 PAD GRADING SECTION
SCALE: NO SCALE

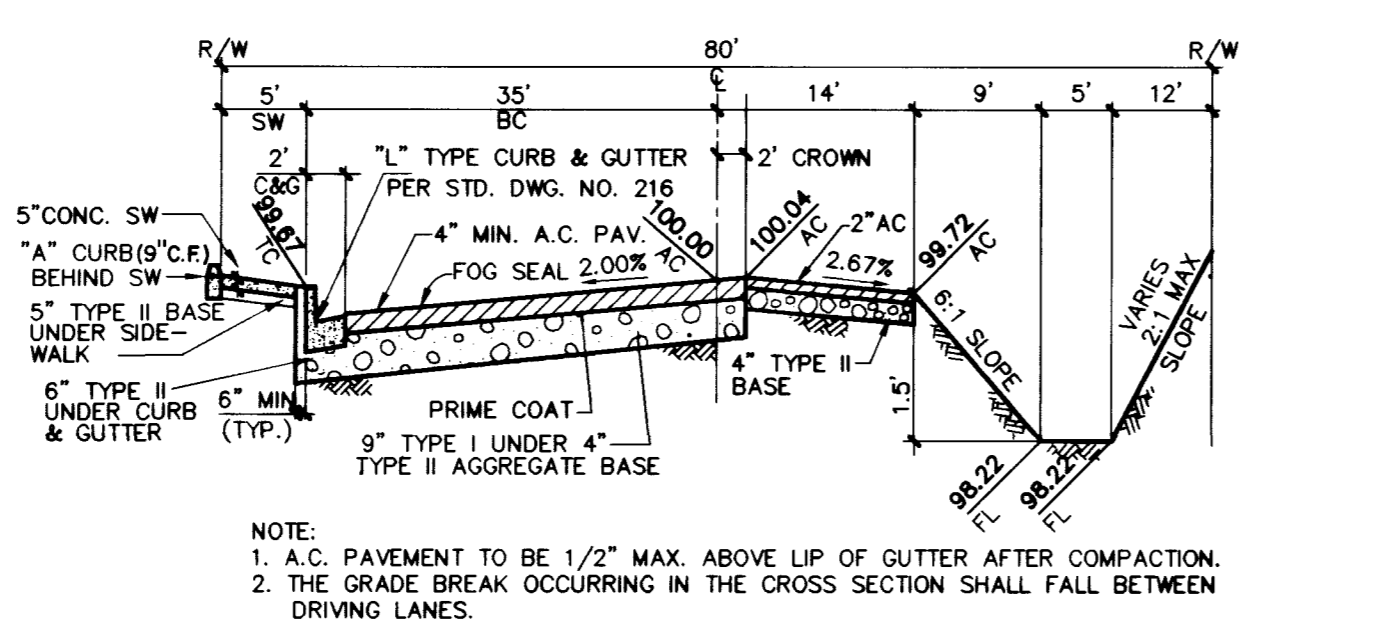

16 TYPICAL STREET SECTION (CIMARRON)
SCALE: NO SCALE

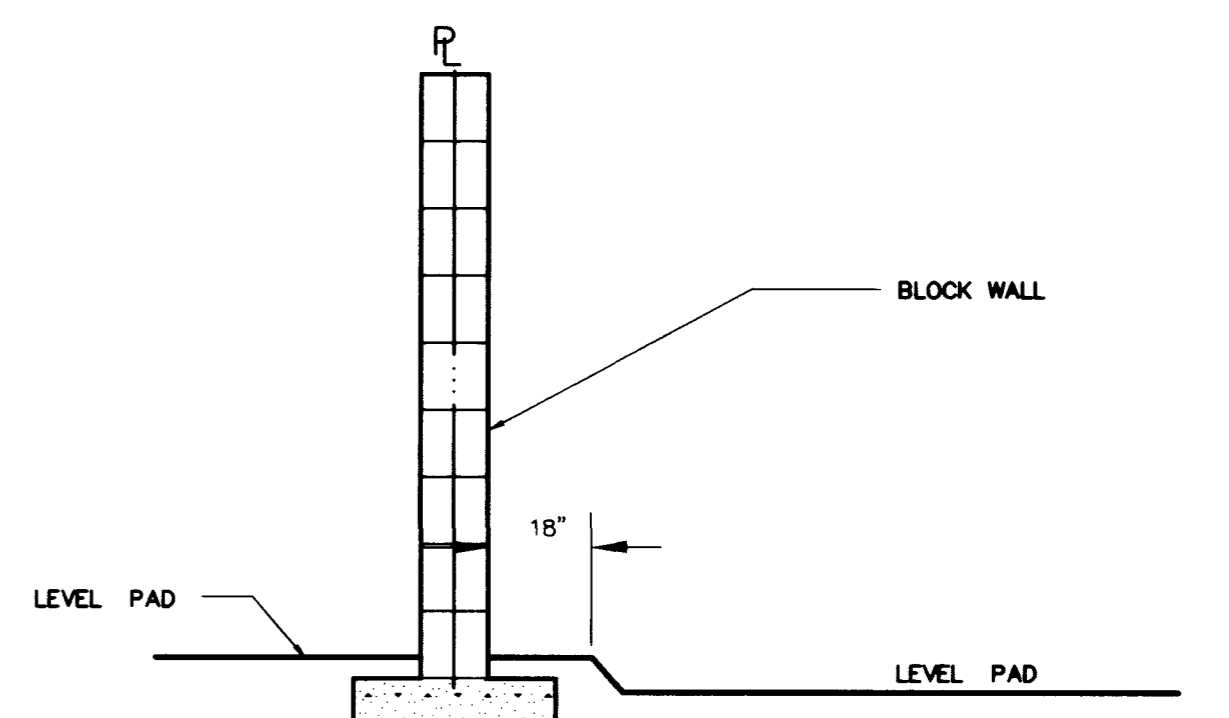

2 TYPICAL SIDE YARD DETAIL
SCALE: NO SCALE

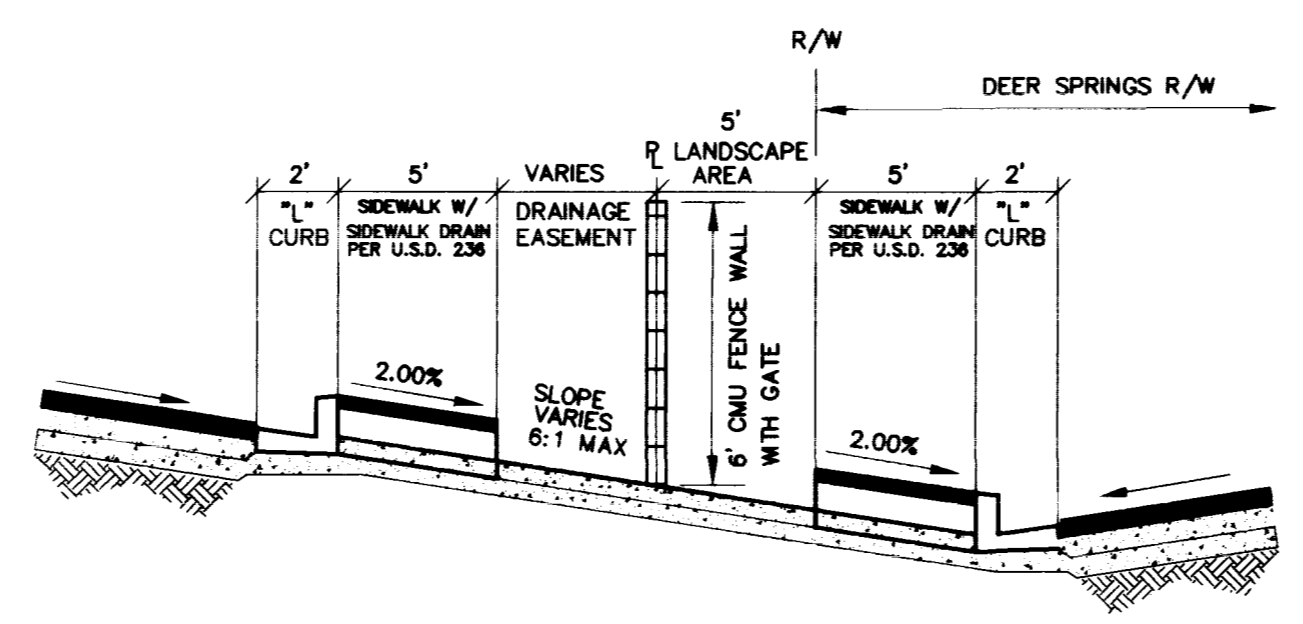

14 SECTION
SCALE: NO SCALE

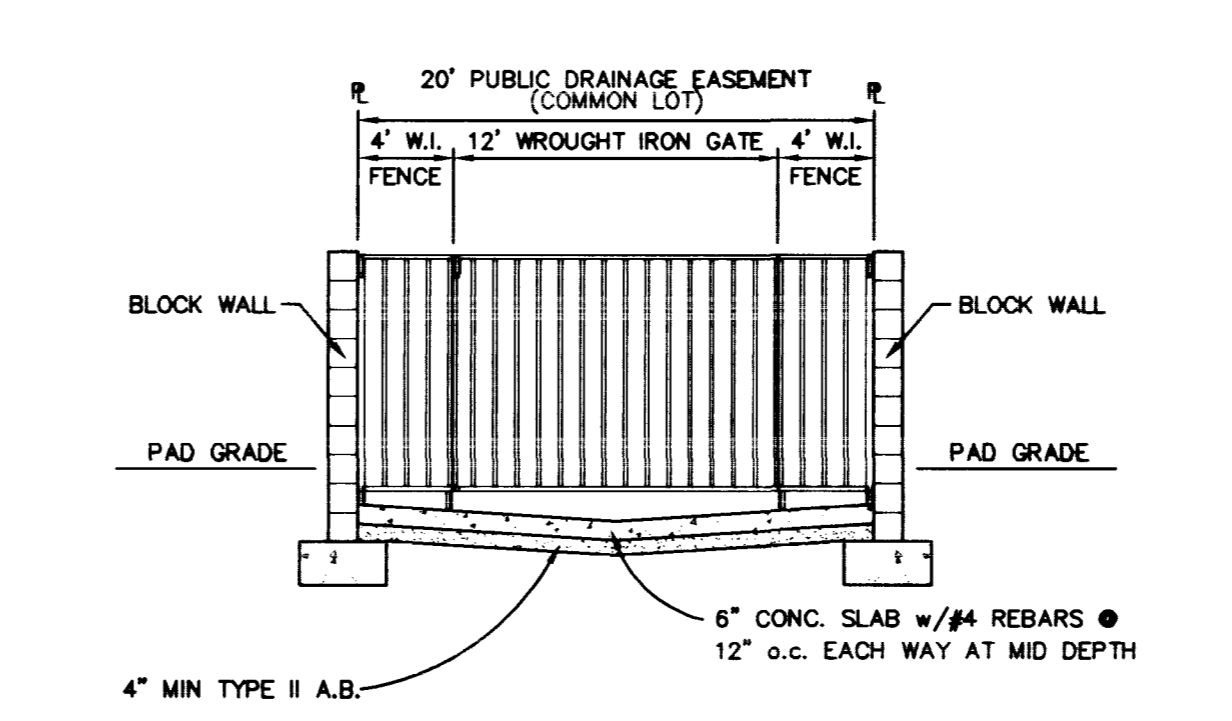

7 20' DRAINAGE EASEMENT GATE DETAIL
SCALE: NO SCALE

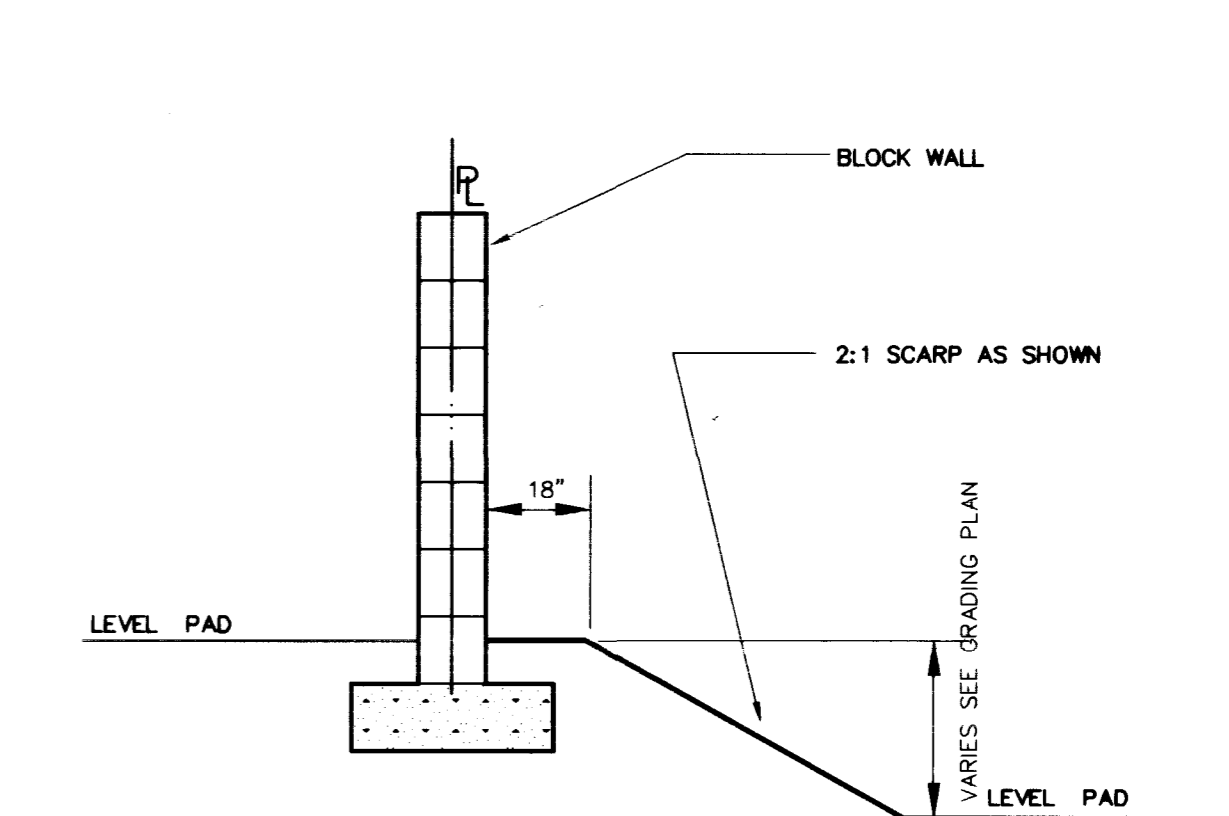

3 REAR YARD DETAIL
SCALE: NO SCALE

NO.	DESCRIPTION	DATE	APP'D

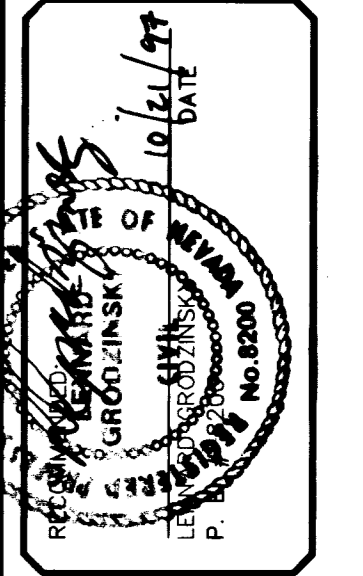

DATE: 9/9/97
DRAWN BY: J. HIRSCHAUER
DESIGNED BY: J. HIRSCHAUER
CHECKED BY: J. HIRSCHAUER
JOB NO.: 0141.0006
SCALE: NONE

PENTACORE
CIVIL ENGINEERING • LAND SURVEYING • PLANNING
CONSTRUCTION MANAGEMENT • ADA CONSULTING
LAS VEGAS, NEVADA 89102 (702)258-0115

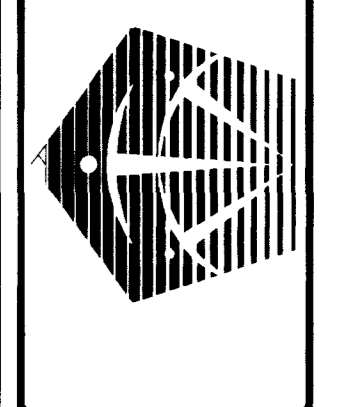

EXECUTIVE DEVELOPMENT CORPORATION
ELKHORN - CIMARRON ESTATES UNIT 4A
GRADING DETAILS

0:\0141\0006\UNIT4A\GRADING\DETAILS Thru Sep 4 13:26:20 1997 J. HIRSCHAUER
 DISK # 0141.0006\UNIT4A\GRADING\

6034

1074-4498-4A

