

DILLSEED DRIVE (PUBLIC)

PROFILE

SCALE: HORIZ. 1" = 40'
 VERT. 1" = 4'

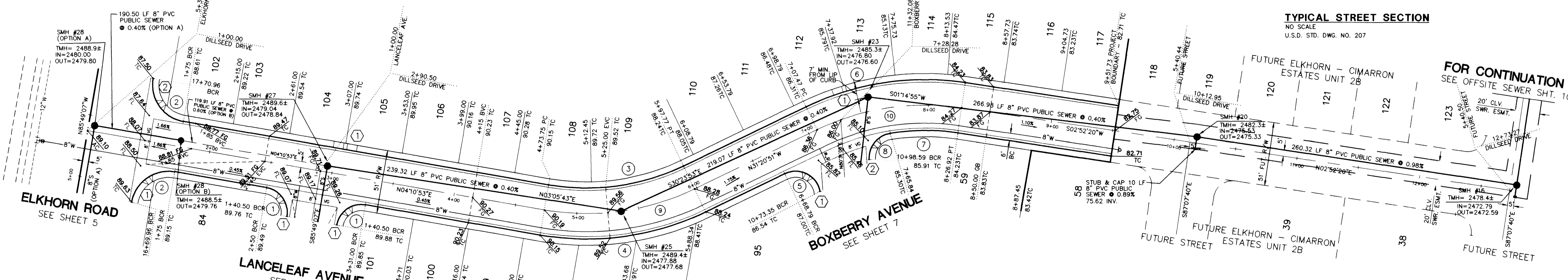
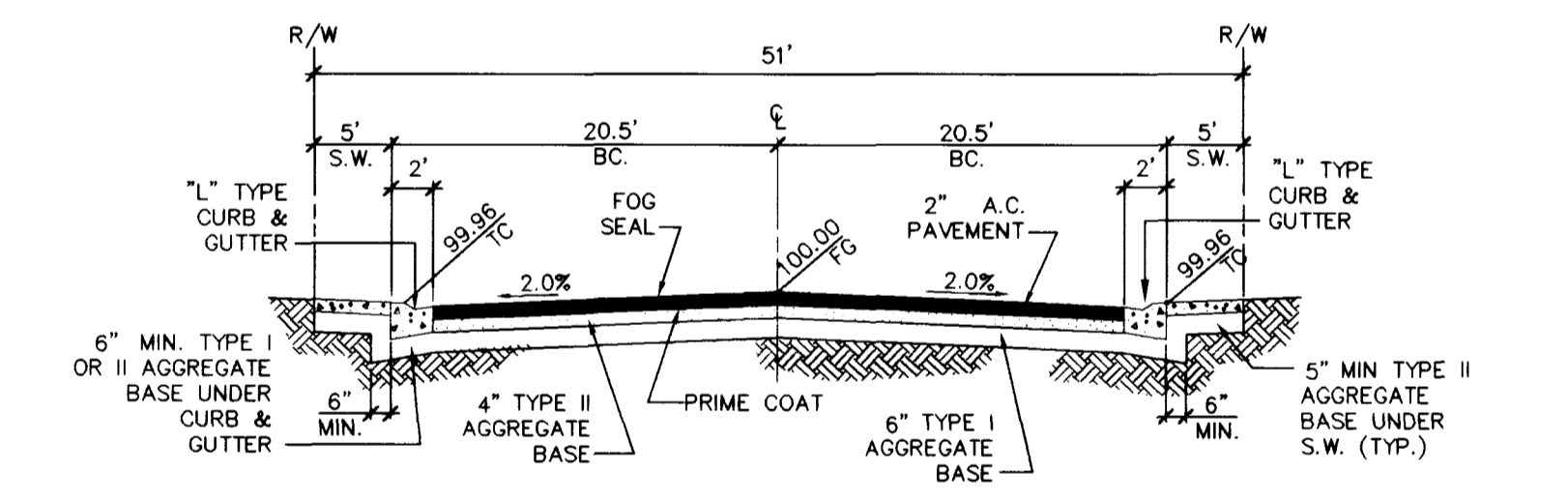

BACK OF CURB CURVE DATA

CURVE	DELTA	RADIUS	LENGTH	TANGENT
1	90°00'00"	20.00'	31.42'	20.00'
2	90°00'00"	30.00'	47.12'	30.00'
3	35°31'45"	179.50'	111.31'	57.51'
4	35°31'45"	220.50'	136.73'	70.64'
5	111°52'00"	20.00'	39.05'	29.58'
6	34°13'12"	220.50'	131.69'	67.88'
7	17°29'51"	179.50'	54.82'	27.62'
8	84°51'21"	20.00'	29.62'	18.28'

CENTERLINE CURVE DATA

CURVE	DELTA	RADIUS	LENGTH	TANGENT
9	35°31'45"	200.00'	124.02'	64.08'
10	34°13'12"	200.00'	119.45'	61.57'

SIDEWALK RAMP TRANSITION TABLE

RAMP NO.	GRADE (%)	"A" (FT) MIN.	"B" (FT) MIN.
1	-2 TO 2	8.0	8.0
2	-3 TO -2.01	4.5	9.5

BENCHMARK
 CLV BM #1 LV90 21 N6
 3" BRASS CAP USC & GS BM #113, 3/4 MILE N OF 1 LV9028NNE6,
 50' E OF OLD RAILROAD BED.
 ELEV. = 748.2584 (METERS) 2454.91' (NAVD88)

PENTACORE
 CIVIL ENGINEERING • LAND SURVEYING • PLANNING
 CONSULTING
 8783 WEST CHARLESTON BOULEVARD
 LAS VEGAS, NEVADA 89102 (702)258-0115

RECOMMENDED: [Signature]
 LENNARD GROZINSKY
 P. E. # 8200
 7/04/14

DATE: 5/19/97
 DRAWN BY: [Signature]
 DESIGNED BY: [Signature]
 CHECKED BY: [Signature]
 JOB NO.: 0141.0006
 SCALE: 1" = 40'

EXECUTIVE DEVELOPMENT CORPORATION
 ELKHORN - CIMARRON ESTATES UNIT 2A
 STREET PLAN - PROFILE
 DILLSEED DRIVE

SHEET **6**
 OF 12

107Y-4498-2A

D:\0141\0006\UNIT2A\PP\0141.DWG Mon May 19 15:07:46 1997 J. HIRSHOBER

DILLSEED.DWG DISK # 0141.0006\UNIT2A.DWG

6064

