

8 SECTION (ELKHORN ROAD)  
SCALE: NO SCALE

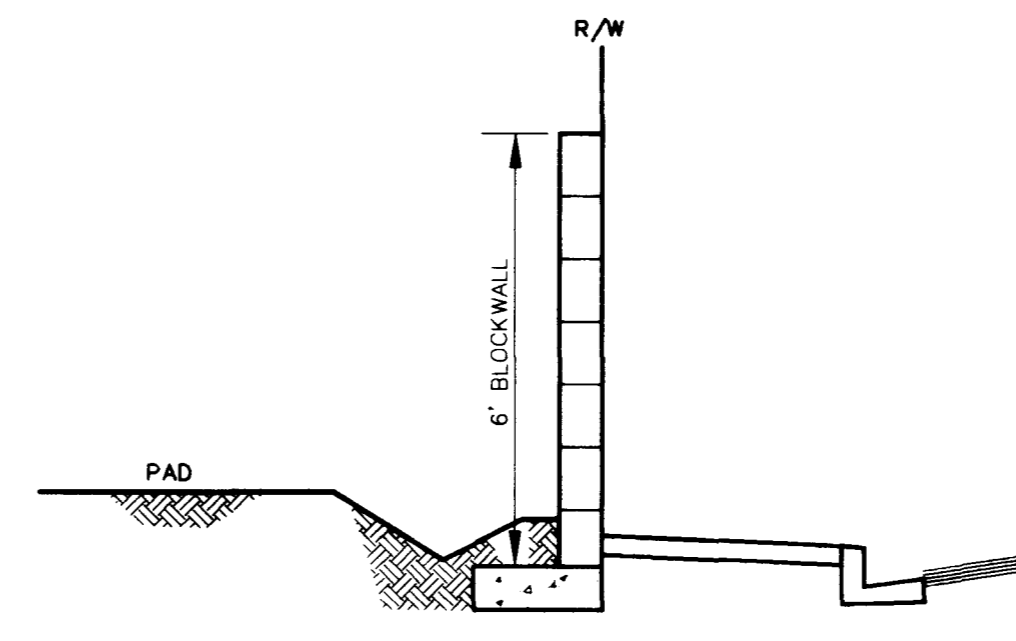

4 SIDE YARD (NO RETAINING WALL)  
SCALE: NO SCALE

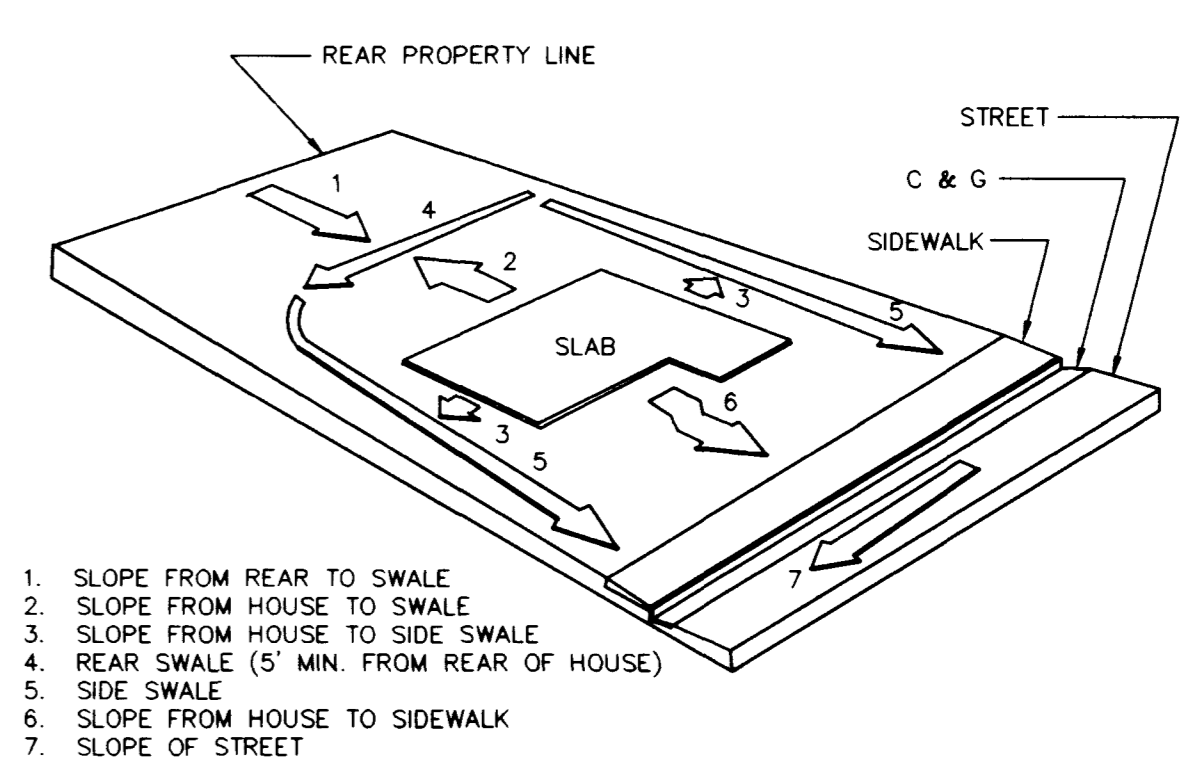

TYPICAL LOT GRADING - TYPE "A"  
SCALE: N.T.S.

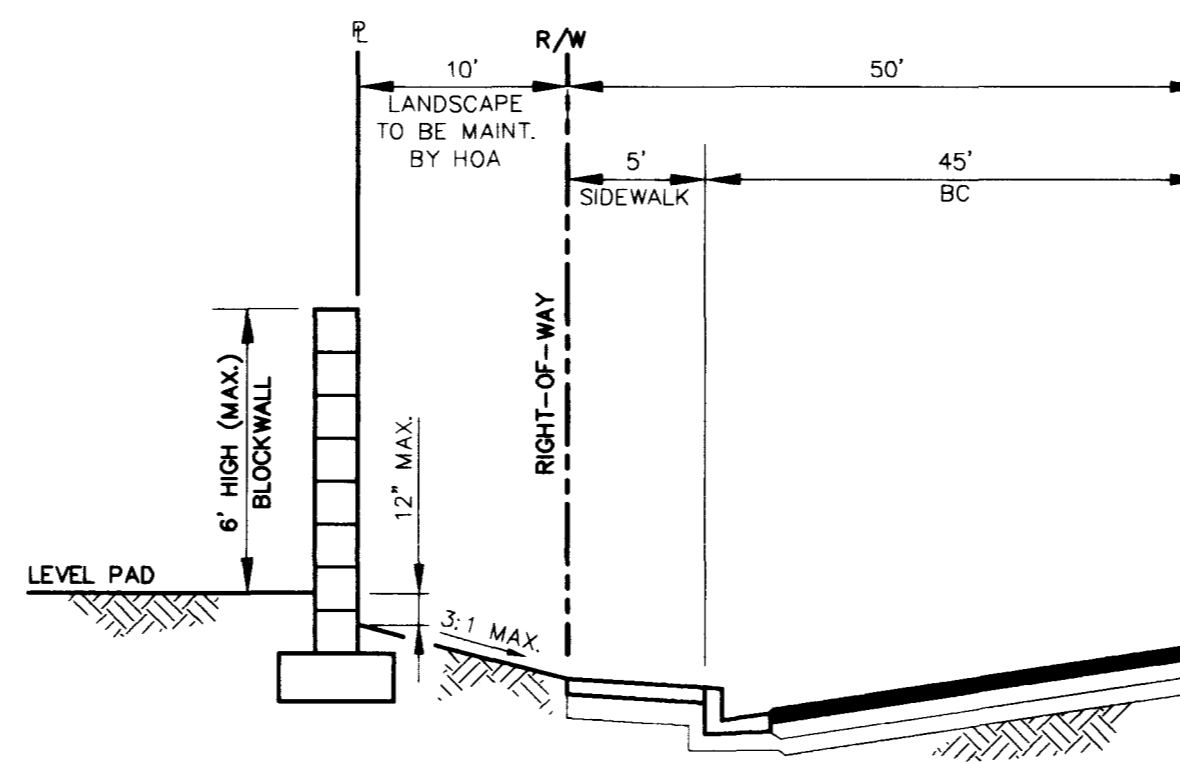

9 SECTION  
SCALE: NO SCALE

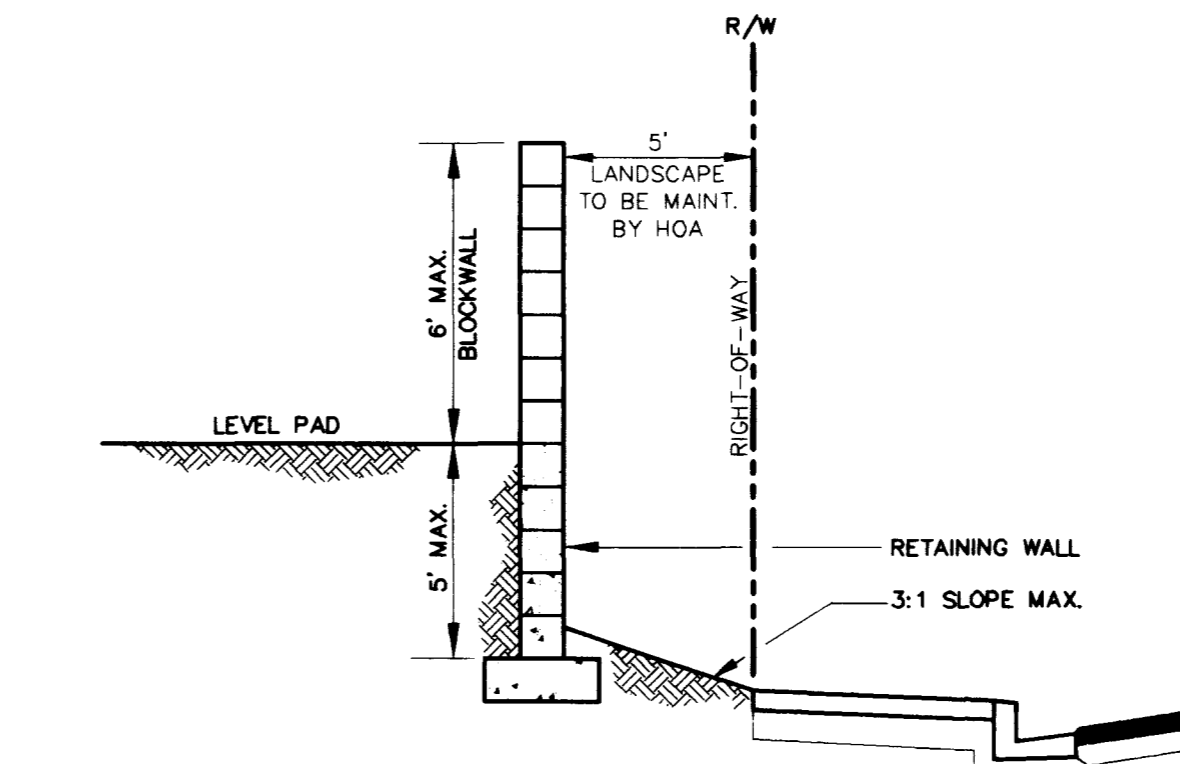

5 SECTION (CIMARRON ROAD)  
SCALE: NO SCALE

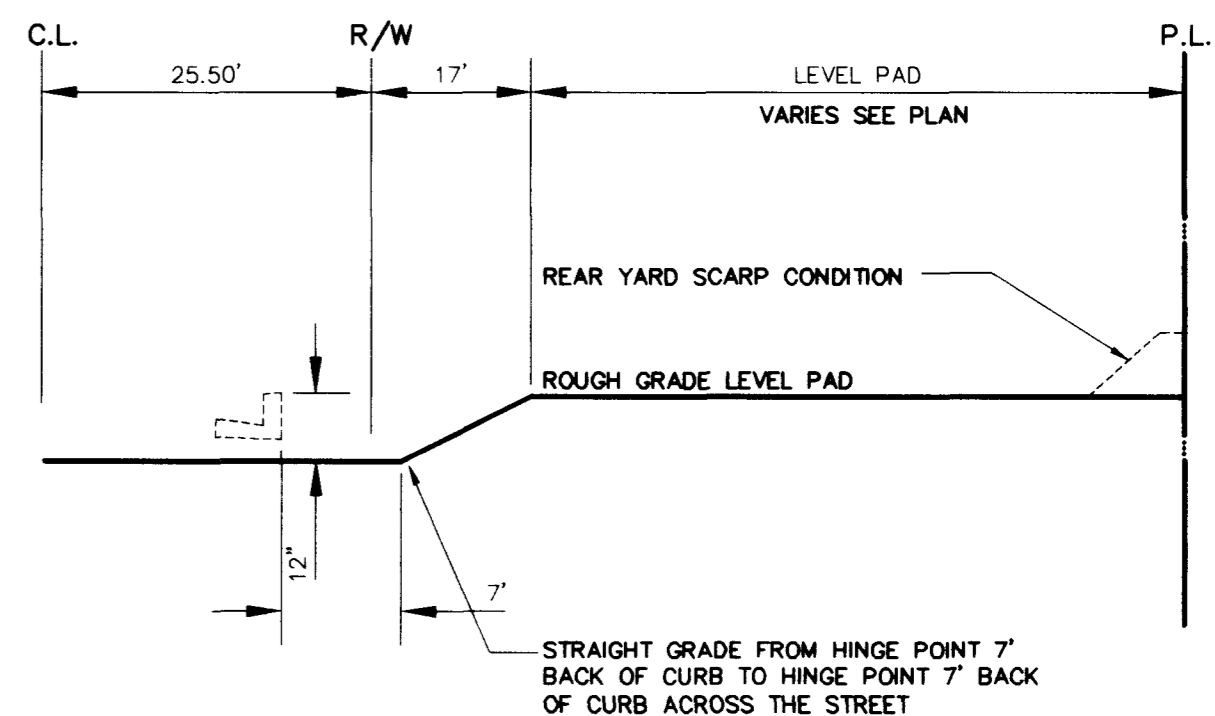

1 PAD GRADING SECTION  
SCALE: NO SCALE

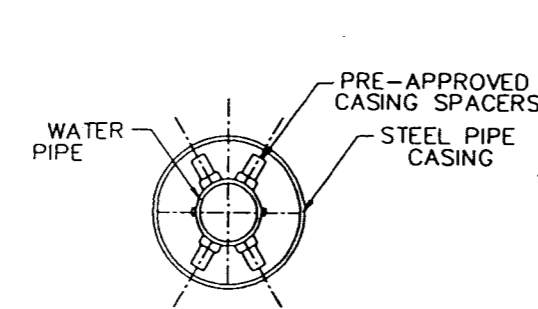

- NOTES
1. STEEL PIPE CASING SYMMETRICAL ABOUT WATER MAIN CENTERLINE.
  2. PRE-APPROVED CASING SPACERS AND PRE-APPROVED END SEALS INSTALLED PER MANUFACTURER'S SPECIFICATIONS. (REDWOOD SKIDS NOT ALLOWED, UDAC'S SECTION 3.26 NOT APPLICABLE). USE A "CENTERED" CONFIGURATION AND PROVIDE THE MANUFACTURER WITH THE FOLLOWING:
    - PIPE OD
    - CASING ID
    - CASING LENGTH
  3. STEEL PIPE CASING SHALL BE FABRICATED FROM A MINIMUM OF 1/4" THICK STEEL PLATES, CONFORMING TO THE REQUIREMENTS OF ASTM A259, GRADE B, C, OR D. ALL JOINTS SHALL BE WELDED. INTERIOR JOINTS SHALL BE GROUNDED TO A SMOOTH FINISH. ALL WELDING SHALL BE PERFORMED IN ACCORDANCE WITH ANNA C281, "ANNA STANDARD FOR FABRICATED ELECTRICALLY WELDED STEEL WATER PIPE". COATINGS FOR STEEL CASING ARE NOT REQUIRED.
  4. PIPE CASING SHALL BE LAID TRUE TO LINE AND GRADE WITH NO BENDS OR CHANGES IN GRADE FOR THE FULL LENGTH OF THE CASING.
  5. THE PIPE SHALL BE SUPPORTED AT EACH END JOINT WITH SPACERS. AFTER INSTALLATION OF THE PIPE, THE CASING SHALL BE SEALED AT BOTH ENDS WITH CASING END SEALS. DUCTILE IRON PIPE JOINTS INSIDE CASING ARE TO BE RESTRAINED.

13 BORE & JACK CASING DETAIL  
SCALE: NO SCALE

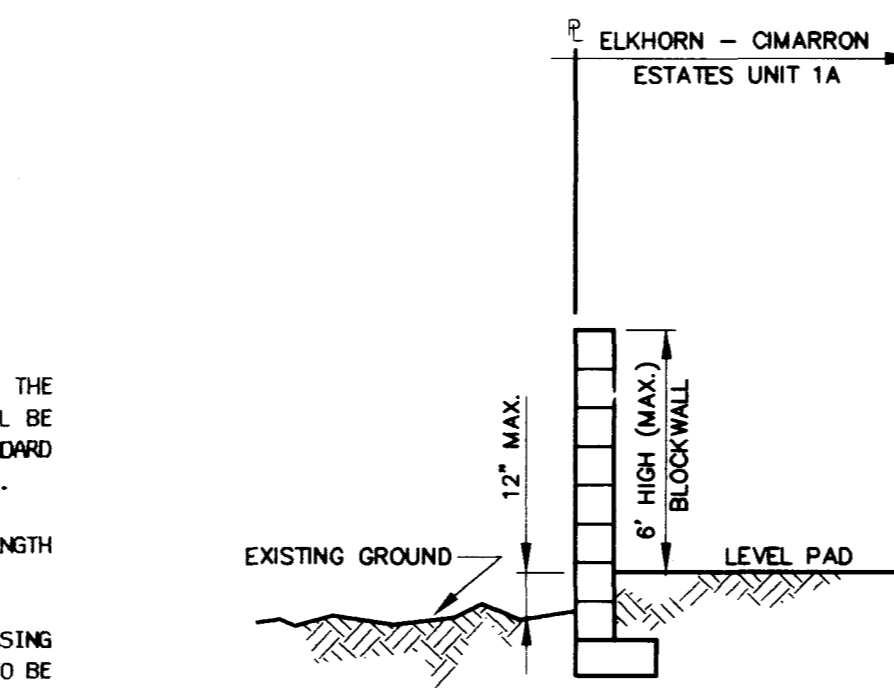

10 SECTION  
SCALE: NO SCALE

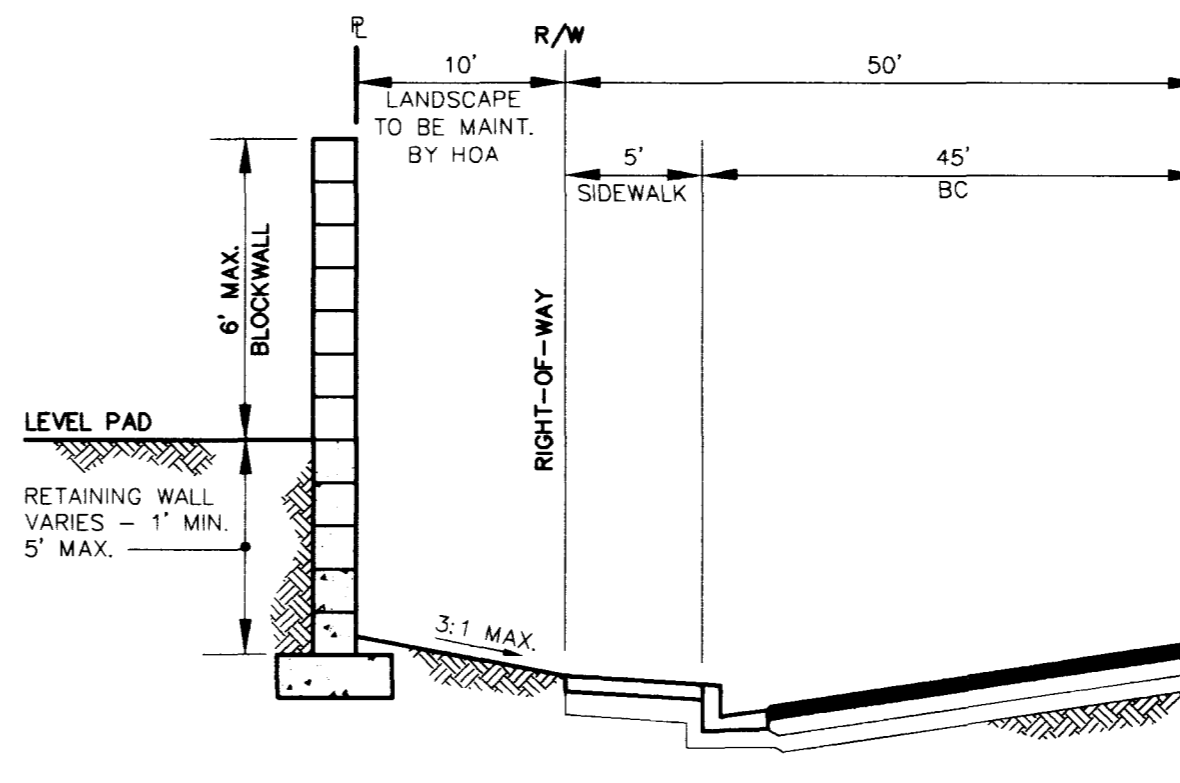

6 SECTION (ELKHORN ROAD)  
SCALE: NO SCALE

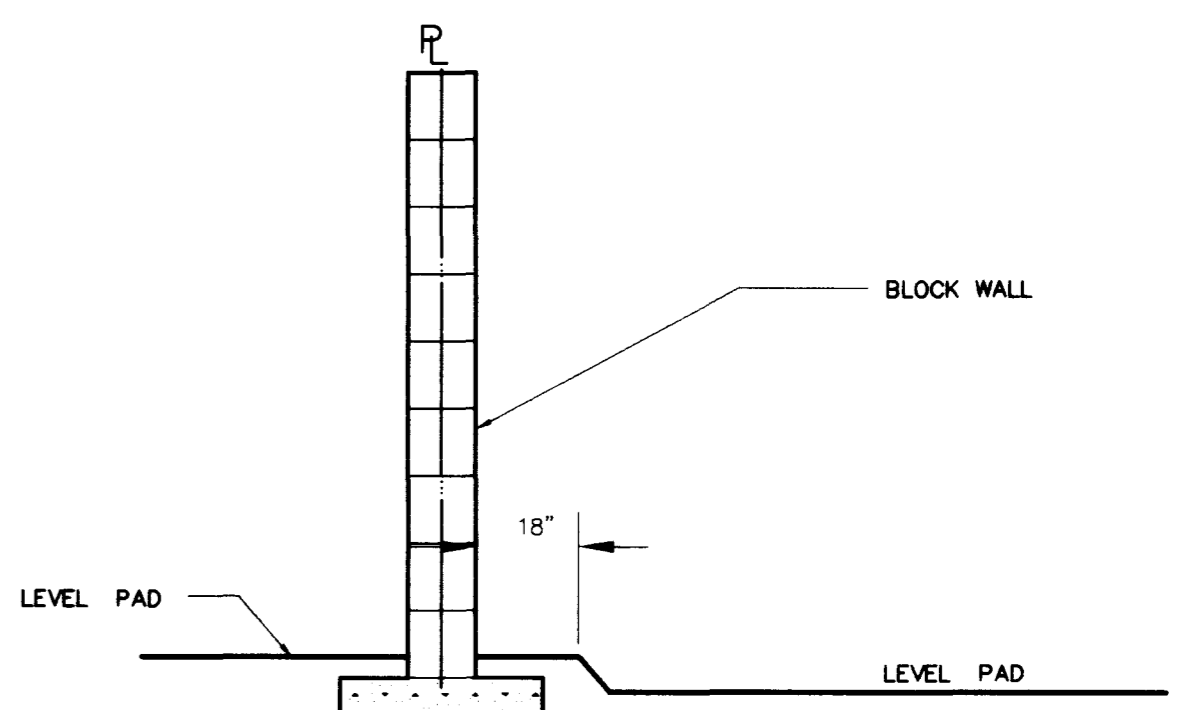

2 TYPICAL SIDE YARD DETAIL  
SCALE: NO SCALE

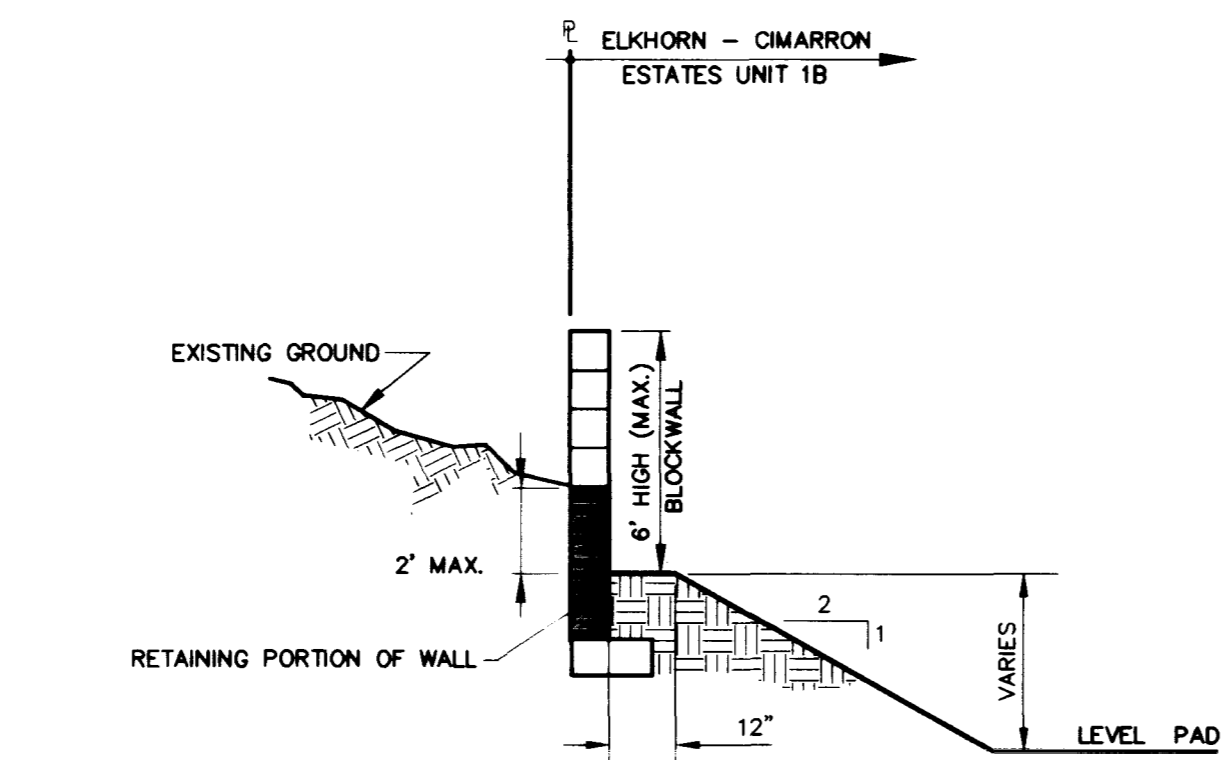

12 SECTION  
SCALE: NO SCALE

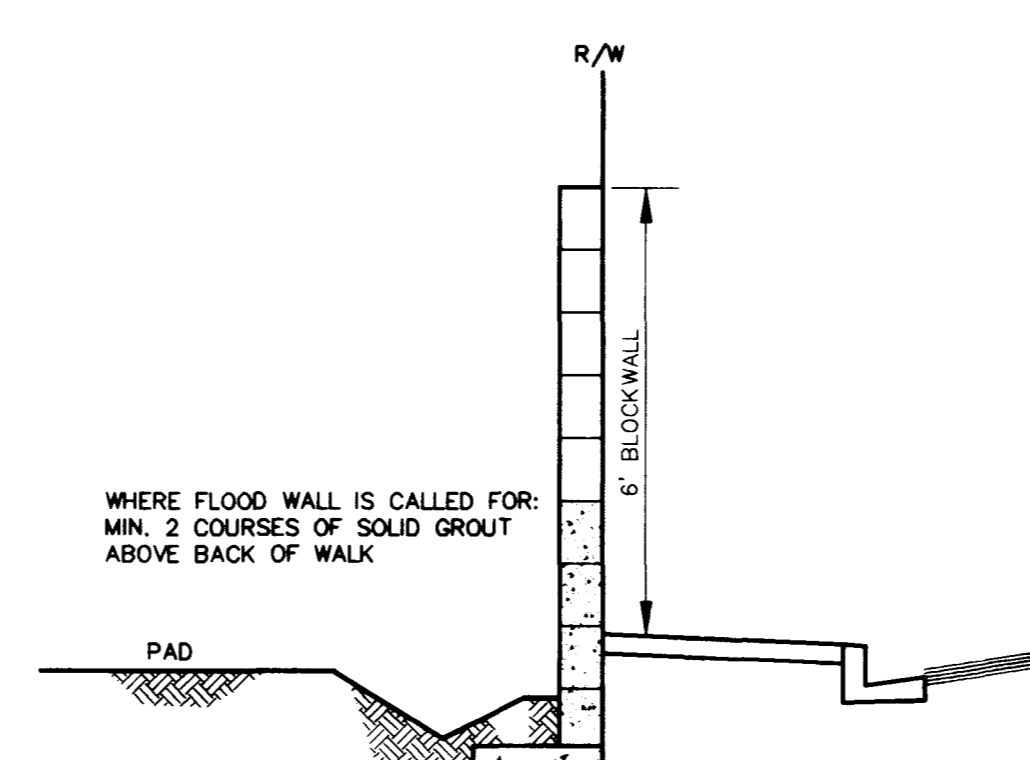

11 SECTION  
SCALE: NO SCALE

APPROVED FOR CONSTRUCTION ESK018

7/31/97  
LAS VEGAS VALLEY WATER DISTRICT DATE

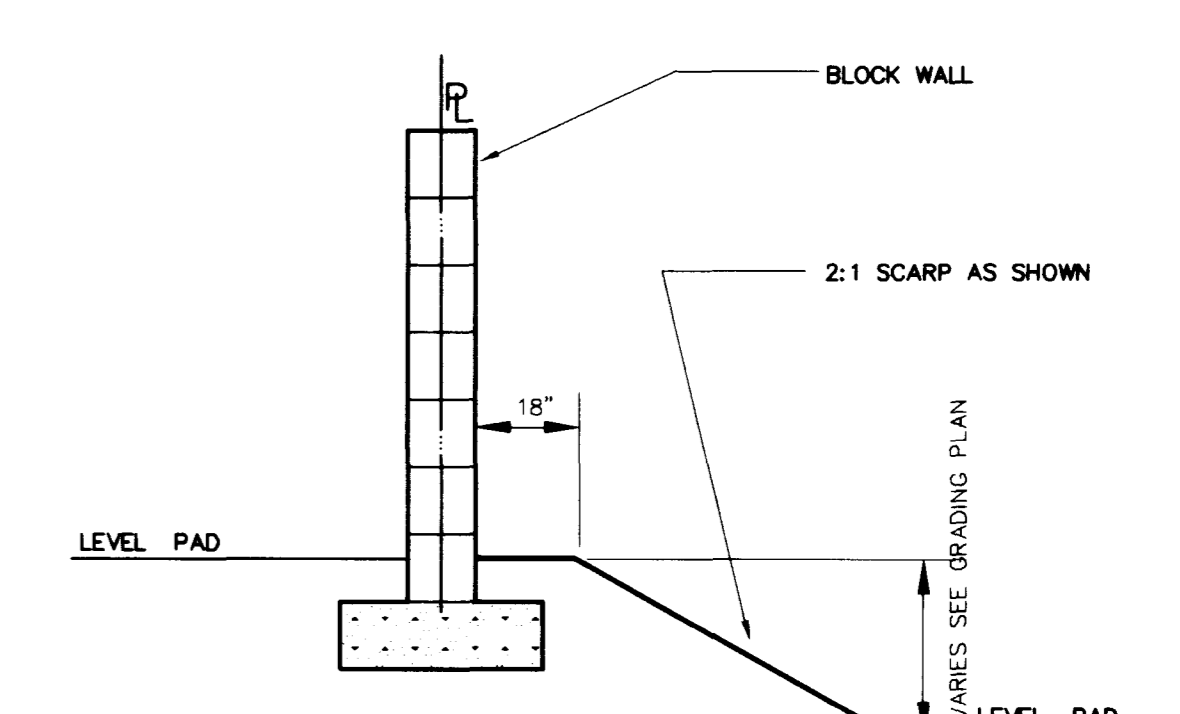

3 REAR YARD DETAIL  
SCALE: NO SCALE

NO.	DESCRIPTION	DATE	APP'D
1	ADDED DETAIL 13A	7/2/97	J. HITSCHNER

RECOMMENDED BY: [Signature]  
DESIGNED BY: [Signature]  
CHECKED BY: [Signature]  
JOB NO.: 0141.0006  
SCALE: NONE

DATE: 7/2/97  
DRAWN BY: [Signature]  
DESIGNED BY: [Signature]  
CHECKED BY: [Signature]  
JOB NO.: 0141.0006  
SCALE: NONE

**PENTACORE**  
CIVIL ENGINEERING • LAND SURVEYING • PLANNING  
CONSTRUCTION MANAGEMENT • ADA CONSULTING  
7205 WEST CHARLES BOULEVARD, SUITE 100  
LAS VEGAS, NEVADA 89102 (702)259-0115

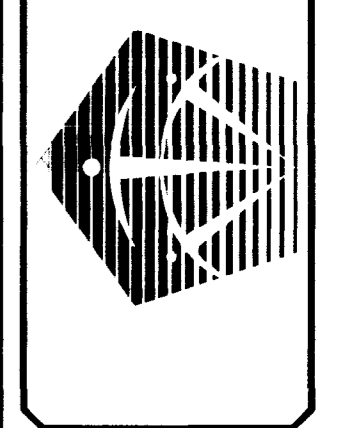

EXECUTIVE DEVELOPMENT CORPORATION  
ELKHORN - CIMARRON ESTATES UNIT 1B  
GRADING DETAILS

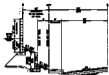

4 SECTION (ELEVATION ROAD)  
SCALE: 1/8" = 1'-0"



5 SEE THIRD (NO RETURNING WALL)  
SCALE: 1/8" = 1'-0"



TYPICAL LOT SHOWING - TYPE "A"  
SCALE: 1/8" = 1'-0"



6 SECTION  
SCALE: 1/8" = 1'-0"



7 SECTION (ELEVATION ROAD)  
SCALE: 1/8" = 1'-0"



1 PLAN SHOWING SECTION  
SCALE: 1/8" = 1'-0"



11 ROOF & JACK GABLE DETAIL  
SCALE: 1/8" = 1'-0"



8 SECTION  
SCALE: 1/8" = 1'-0"



9 SECTION (ELEVATION ROAD)  
SCALE: 1/8" = 1'-0"

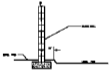

2 TYPICAL SIDE VIEW DETAIL  
SCALE: 1/8" = 1'-0"



10 SECTION  
SCALE: 1/8" = 1'-0"



11 SECTION  
SCALE: 1/8" = 1'-0"

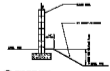

3 SIDE VIEW DETAIL  
SCALE: 1/8" = 1'-0"

*Handwritten signature*

<p>DATE: 10/15/54                  DRAWN BY: [Name]                  CHECKED BY: [Name]                  PROJECT: [Name]</p>	
<p><b>PENTACORE</b>                  ARCHITECTS                  1000 [Address]                  [City, State]</p>	
<p>EXCLUSIVE DEVELOPMENT COMPANY                  1000 [Address]                  [City, State]</p>	
<p>14-100000-1-1000</p>	