

CITY OF LAS VEGAS GENERAL NOTES

- ALL CONSTRUCTION AND MATERIALS SHALL BE IN ACCORDANCE WITH THE "UNIFORM STANDARD SPECIFICATIONS FOR PUBLIC WORKS CONSTRUCTION OFFSITE IMPROVEMENTS, CLARK COUNTY AREA NEVADA", LATEST ISSUE, THE "UNIFORM STANDARD DRAWINGS FOR PUBLIC WORKS CONSTRUCTION, CLARK COUNTY AREA NEVADA", LATEST ISSUE, AND OTHER APPLICABLE APPROVED STANDARDS ISSUED BY THE CONTROLLING AGENCY; THE UNIFORM BUILDING CODE AND ALL LOCAL CITY CODES AND ORDINANCES APPLICABLE, EXCEPT AS NOTED ON THIS SHEET AS "DEVIATIONS FROM STANDARDS".
- THE EXISTENCE AND LOCATION OF ANY OVERHEAD OR UNDERGROUND UTILITY LINES, PIPES, OR STRUCTURES SHOWN ON THESE PLANS ARE OBTAINED BY A RESEARCH OF THE AVAILABLE RECORDS. EXISTING UTILITIES ARE LOCATED ON PLANS ONLY FOR THE CONVENIENCE OF THE CONTRACTOR. EXISTING UTILITY SERVICE LATERALS MAY NOT BE SHOWN ON THE PLANS. THE CONTRACTOR SHALL, AT HIS OWN EXPENSE, LOCATE ALL UNDERGROUND AND OVERHEAD INTERFERENCES WHICH MAY AFFECT HIS OPERATION DURING CONSTRUCTION AND SHALL TAKE ALL NECESSARY PRECAUTIONS TO AVOID DAMAGE TO SAME. THE CONTRACTOR SHALL USE EXTREME CAUTION WHEN WORKING NEAR OVERHEAD OR UNDERGROUND POWER, GAS AND/OR OTHER UTILITIES SO AS TO SAFELY PROTECT ALL PERSONNEL AND EQUIPMENT, AND SHALL BE RESPONSIBLE FOR ALL COSTS AND LIABILITY IN CONNECTION THEREWITH.
- THE CONTRACTOR SHALL TAKE ALL PRECAUTIONARY MEASURES NECESSARY TO PROTECT EXISTING UTILITY LINES, STRUCTURES, AND STREET IMPROVEMENTS WHICH ARE TO REMAIN IN PLACE FROM DAMAGE, AND ALL SUCH IMPROVEMENTS OR STRUCTURES DAMAGED BY THE CONTRACTOR'S OPERATIONS SHALL BE REPAIRED OR REPLACED SATISFACTORY TO THE CITY ENGINEER OR OWNING UTILITY COMPANY AT THE EXPENSE OF THE CONTRACTOR.
- ALL CONSTRUCTION SHALL BE AS SHOWN ON THESE PLANS, ANY REVISIONS SHALL HAVE THE PRIOR WRITTEN APPROVAL OF THE CITY ENGINEER.
- TYPE V CEMENT SHALL BE USED IN ALL OFFSITE CONCRETE WORK. CONCRETE TO BE 3000 PSI MINIMUM @ 28 DAYS. MIX DESIGN TO APPROVED BY THE QUALITY CONTROL DIVISION PRIOR TO USE ON THE PROJECT.
- PERMITS ARE REQUIRED FOR ANY WORK IN THE PUBLIC RIGHT-OF-WAY. THE CONTRACTOR SHALL SECURE ALL PERMITS AND INSPECTIONS REQUIRED FOR THIS CONSTRUCTION.
- EXPANSION JOINTS REQUIRED, MAXIMUM EVERY 300' IN EXTRUDED TYPE CURB.
- AC PAVEMENT TO BE 1/2" ABOVE LIP OF ALL GUTTERS AFTER COMPACTION, EXCEPT AT SIDEWALK RAMPS.
- APPLY FOG SEAL ONLY AFTER ALL CORRECTIONS AND ADJUSTMENTS HAVE BEEN MADE.
- CURB & GUTTER WITH A GRADE OF LESS THAN FOUR TENTHS OF ONE PERCENT SHALL BE WATER TESTED AS SOON AS POSSIBLE AFTER CONSTRUCTION. ANY CURB AND GUTTER FOUND TO BE UNACCEPTABLE TO THE CITY SHALL BE REMOVED AND REPLACED.
- SIDEWALK RAMPS SHALL BE CONSTRUCTED IN EACH QUADRANT OF AN INTERSECTION PER STD. DWG. 235. EXACT LOCATION OF RAMPS MAY BE ADJUSTED IN THE FIELD BY A CITY INSPECTOR.
- CONTRACTOR SHALL PROVIDE ALL NECESSARY HORIZONTAL AND VERTICAL TRANSITIONS BETWEEN NEW CONSTRUCTION AND EXISTING SURFACES TO PROVIDE FOR PROPER DRAINAGE AND FOR INGRESS AND EGRESS TO NEW CONSTRUCTION. THE EXTENT OF TRANSITIONS TO BE AS SHOWN ON PLANS, OR AS DESIGNED IN THE FIELD BY A CITY INSPECTOR.
- ALL GRADING WORK SHALL CONFORM TO THE SOILS REPORT AS PREPARED BY TERRACON CONSULTANTS WESTERN, INC., PROJECT NO. 64953351, DATED DEC. 21, 1995, AND APPROVED BY THE CITY ENGINEER, AND AS SHOWN ON THESE PLANS.
- EXACT LOCATION OF ALL SAWCUT LINES MAY BE DETERMINED IN THE FIELD BY A CITY OF LAS VEGAS INSPECTOR IF LOCATION ON PLANS IS NOT CLEARLY SHOWN, OR EXISTING PAVEMENT CONDITION REQUIRES RELOCATION.
- THE CONTRACTOR SHALL TAKE ALL PRECAUTIONS NECESSARY TO PROTECT EXISTING PERMANENT SURVEY MONUMENTS. ANY MONUMENTS DISTURBED SHALL BE REPLACED AND ADJUSTED PER AVAILABLE RECORDS IN ACCORDANCE WITH N.R.S. STATUTE NO. 625.550.
- UTILITY COMPANY METER BOXES, MANHOLE LIDS, VALVE COVERS, ETC. SHALL BE LOCATED OUT OF DRIVEWAYS, DRIVEWAY APRONS, FLOWLINES, AND GROSS GUTTERS UNLESS WRITTEN APPROVAL IS GRANTED BY THE UTILITY COMPANY AND CITY ENGINEER.
- WALL NOTES:
 - ALL WALLS, NEW OR EXISTING, ARE ONLY SHOWN FOR THE PURPOSE OF GRADING RELATIONSHIPS.
 - THE STRUCTURAL AND ARCHITECTURAL DESIGN OF ALL WALLS (RETAINING OR NON-RETAINING) MUST BE APPROVED BY THE CLV BUILDING DEPARTMENT.
- ASPHALT MIX DESIGN MUST BE SUBMITTED AND APPROVED BY THE CITY ENGINEER PRIOR TO THE PLACEMENT OF ASPHALT ON CITY STREETS.

ABBREVIATIONS

- | | | | |
|--------|-------------------------|-----|--------------------------------|
| BC STA | BACK OF CURB STATION | LP | LOW POINT |
| BCR | BEGIN. OF CURB RETURN | MVC | MIDDLE OF VERTICAL CURVE |
| BFE | BASE FLOOD ELEVATION | N | NORTH |
| BVC | BEGIN VERTICAL CURVE | OC | ON CURVE |
| BW | BACK OF WALK | PC | POINT OF CURVATURE |
| CL | CENTERLINE | PI | POINT OF INTERSECTION |
| CL INT | CENTERLINE INTERSECTION | PT | POINT OF TANGENCY |
| E | EAST | PVI | POINT OF VERTICAL INTERSECTION |
| ECR | END OF CURB RETURN | R/W | RIGHT-OF-WAY |
| EVC | END VERTICAL CURVE | S | SOUTH OR SEWER |
| FF | FINISH FLOOR | TC | TOP OF CURB |
| FG | FINISH GRADE | TP | TOP OF PIPE |
| FL | FLOW LINE | VC | VERTICAL CURVE |
| GB | GRADE BREAK | W | WEST OR WATER |
| HP | HIGH POINT | VG | VALLEY GUTTER |
| INV | INVERT | | |

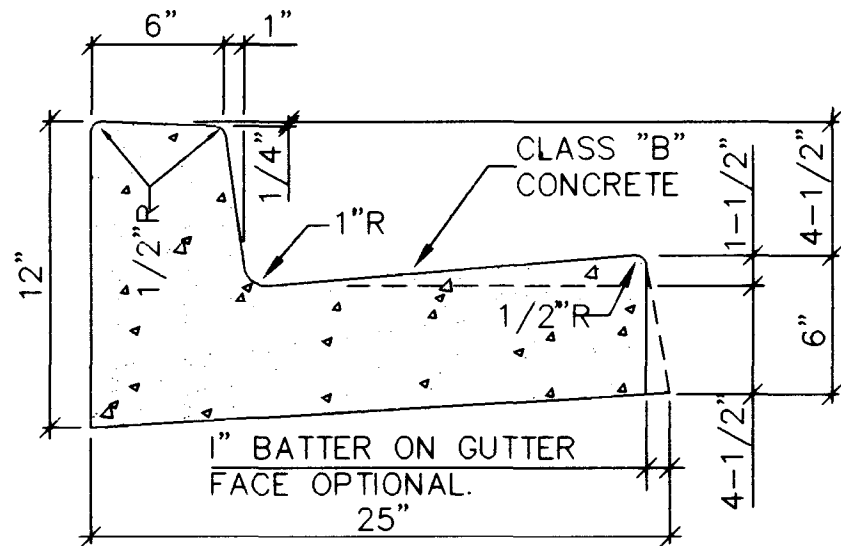

"L" TYPE CURB & GUTTER
PER STD. DWG. 216
NO SCALE

STREET LIGHTING NOTES

- ALL STREET LIGHTING INSTALLATIONS EXCEPT AS NOTED ON THE STREET LIGHTING PLANS SHALL CONFORM TO THE IMPROVEMENT STANDARDS, DEPARTMENT OF PUBLIC WORKS, CITY OF LAS VEGAS, NEVADA, AND THE UNIFORM STANDARD SPECIFICATIONS FOR PUBLIC WORKS CONSTRUCTION, OFF-SITE IMPROVEMENTS, CLARK COUNTY AREA, NEVADA.
- ALL STREET LIGHT POLES SHALL BE GALVANIZED.

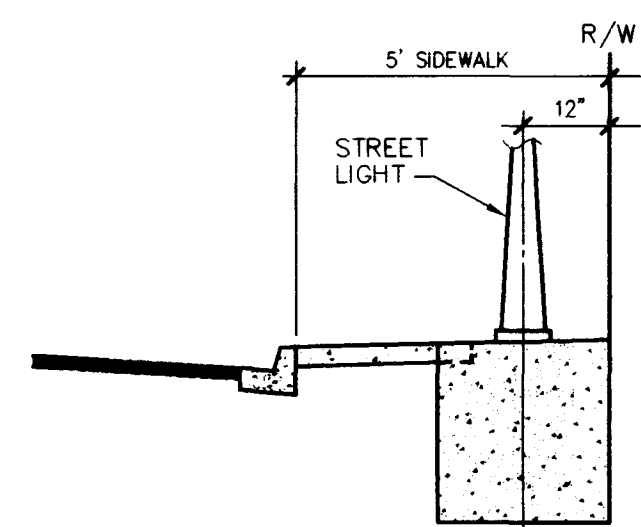

TYPICAL STREET LIGHT LOCATION DETAIL

DEVIATIONS FROM STANDARDS

NONE

ESTIMATE OF QUANTITIES

ITEM	QUANTITY	TOTAL
STREET IMPROVEMENTS (PUBLIC)		
1. 2" A.C. PWMT.		6,639 SY
2. 4" A.C. PWMT.		2,193 SY
3. 4" TYPE II BASE		972 CY
4. 6" TYPE I BASE		1,107 CY
5. 9" TYPE I BASE		548 CY
6. 5' SIDEWALK W/6" TYPE II BASE		18,059 SF
7. 24" "L" TYPE CURB AND GUTTER		3,620 LF
8. CONCRETE DRIVEWAY W/6" TYPE II BASE		5,900 SF
9. CONCRETE VALLEY GUTTER W/10" TYPE I BASE		2,574 SF
10. SIDEWALK RAMPS		8 EA

* THESE QUANTITIES ARE ONLY APPROXIMATE AND BASED ON AN AVERAGE SIZE OF 16'+4" X 3.5' SW (APPROX. 70 SF) AND AN AVERAGE SIZE OF 16'+4" X 5' SW (APPROX. 100 SF). FINAL DRIVEWAY QUANTITIES WILL BE DETERMINED SUBSEQUENT TO THE PREPARATION OF PLOT PLANS.

TRAFFIC

1. 200 WATT HPS LUMINAIRE W/11 GA. POLE	3 EA
2. 100 WATT HPS LUMINAIRE W/11 GA. POLE	9 EA
3. 1 1/4" PVC CONDUIT	1,431 LF
4. 2" PVC CONDUIT	1,264 LF
5. NO. 3 ELECTRICAL PULL BOX	3 EA
6. NO. 5 ELECTRICAL PULL BOX	2 EA
7. 6" D-3 STREET NAME SIGN	3 EA
8. 30" STOP SIGN	1 EA
9. "END OF ROAD" SIGN	3 EA

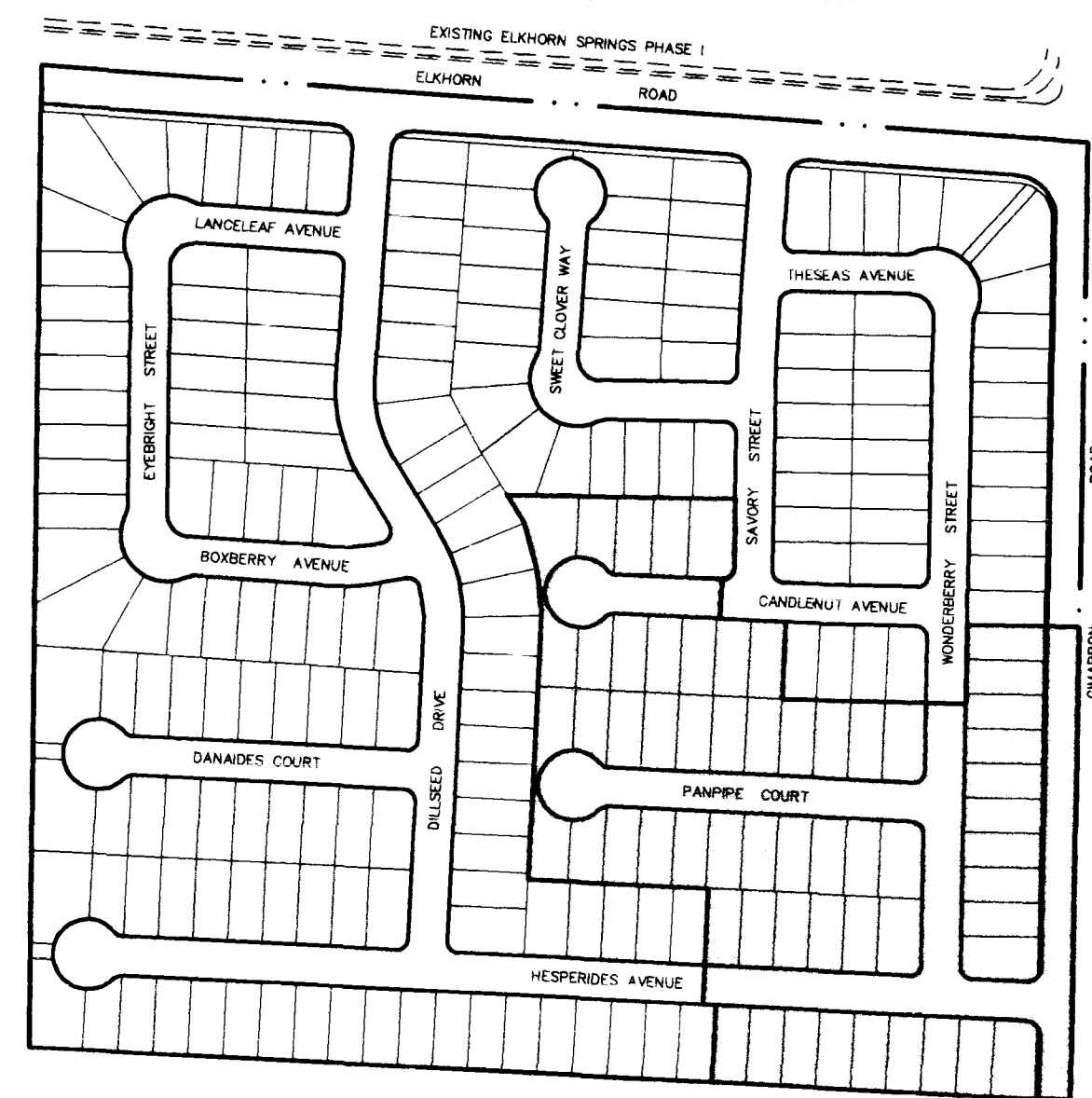

KEY MAP
(NOT TO SCALE)

LEGEND

---	R/W LINE	---	SWALE
---	SUBDIVISION LIMITS	---	GRADE BREAK
---	STREET CENTERLINE	---	2:1 SCARP
---	EXISTING IMPROVEMENTS	---	EXISTING WATER LINE
---	FUTURE IMPROVEMENTS	---	PROPOSED WATER LINE
---	LOT NUMBER	---	EXISTING SEWER LINE
---	EXISTING PAD ELEVATION	---	PROPOSED SEWER LINE
---	PROPOSED PAD ELEVATION	---	EXISTING SEWER MANHOLE
---	FUTURE PAD ELEVATION	---	PROPOSED SEWER MANHOLE
---	EXISTING ELEVATION	---	EXISTING STORM DRAIN LINE
---	PROPOSED ELEVATION	---	PROPOSED STORM DRAIN LINE
---	FUTURE ELEVATION	---	PROPOSED STORM DRAIN MANHOLE
---	EXISTING CONTOUR 1	---	PROPOSED SIDEWALK RAMP PER STD. DETAIL NO. 235, CASE 1 (A AND B LENGTHS AS SHOWN ON PLANS)
---	EXISTING CONTOUR 5	---	
---	PROPOSED CONTOUR	---	
---	BLOCK NUMBER	---	
---	EXISTING EDGE OF PAVEMENT	---	

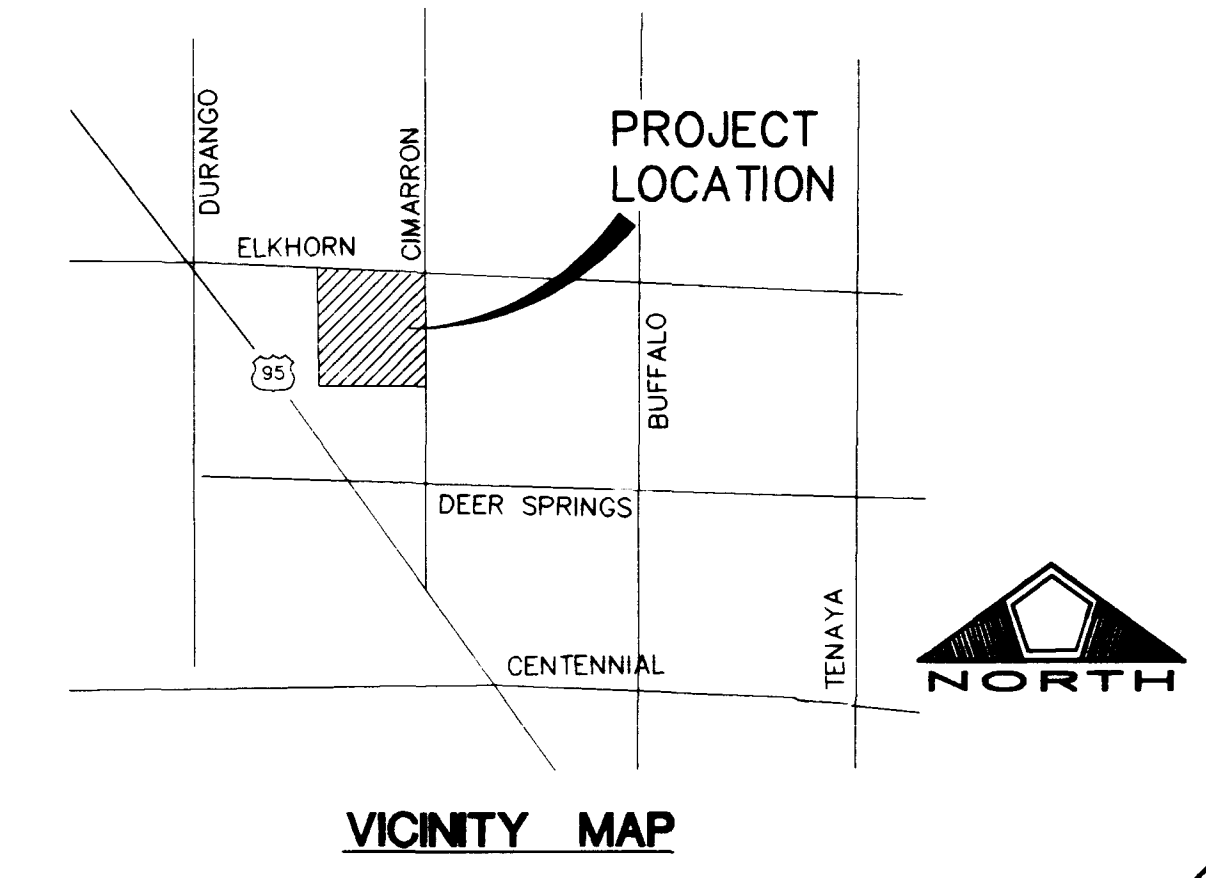

VICINITY MAP

INDEX OF DRAWINGS

SHT. NO.	DESCRIPTION
1	COVER
2	SHEET INDEX, GENERAL NOTES
3	UTILITY NOTES
4	UTILITY PLAN
5	PANPIPE COURT - PLAN & PROFILE
6	HESPERIDES AVENUE - PLAN & PROFILE
7	CANDLENUT AVENUE - PLAN & PROFILE
8	WONDERBERRY STREET - PLAN & PROFILE
9	CIMARRON ROAD - PLAN & PROFILE
10	GRADING PLAN
11	GRADING DETAILS
12	OFFSITE WATERLINE PLAN

OWNER / DEVELOPER

ELKHORN - CIMARRON ROAD
A LIMITED PARTNERSHIP
C/O EXECUTIVE DEVELOPMENT CORPORATION
6773 WEST CHARLESTON BLVD.
LAS VEGAS, NEVADA 89102
(702) 877-6222

LEGAL DESCRIPTION

A PORTION OF THE NORTHEAST QUARTER (NE 1/4) OF THE NORTHWEST QUARTER (NW 1/4) OF SECTION 21, TOWNSHIP 19 SOUTH, RANGE 80 EAST, M.D.M. CITY OF LAS VEGAS, CLARK COUNTY, NEVADA.

BENCHMARK

CLV BM # 1 LV80 21 N8
3" BRASS CAP USC & GS BM #113, 3/4 MILE N OF 1 LV8028NNE8,
60' E OF OLD RAILROAD BED.
ELEV. = 748.2684 (METERS) 2454.81 (NAVD88)

BASIS OF BEARING

NORTH 85°49'07" WEST, BEING THE NORTH LINE OF THE NORTHWEST QUARTER (NW 1/4) OF THE NORTHWEST QUARTER (NW 1/4) OF SECTION 21, TOWNSHIP 19 SOUTH, RANGE 80 EAST, M.D.M. AS SHOWN ON A RECORD OF SURVEY IN FILE 73, PAGE 26, IN THE CLARK COUNTY NEVADA RECORDERS OFFICE.

NO.	DESCRIPTION	DATE	APP'D.

REVISIONS
DATE: 7/2/97
DRAWN BY: [Signature]
DESIGNED BY: [Signature]
CHECKED BY: [Signature]
JOB NO.: 0141.0006
SCALE: NONE

DATE: 7/2/97
DRAWN BY: [Signature]
DESIGNED BY: [Signature]
CHECKED BY: [Signature]
JOB NO.: 0141.0006
SCALE: NONE

PENTACORE
CIVIL ENGINEERING, LAND SURVEYING, PLANNING
CONSTRUCTION MANAGEMENT, ADA CONSULTING
6763 WEST CHARLESTON BOULEVARD
LAS VEGAS, NEVADA 89102 (702)258-0115

EXECUTIVE DEVELOPMENT CORPORATION
ELKHORN - CIMARRON ESTATES UNIT 1B
SHEET INDEX, GENERAL NOTES

