

CONCRETE 'U' GUTTER
SECTION (LOTS 1,37,59,78) N.T.S. **F 3**

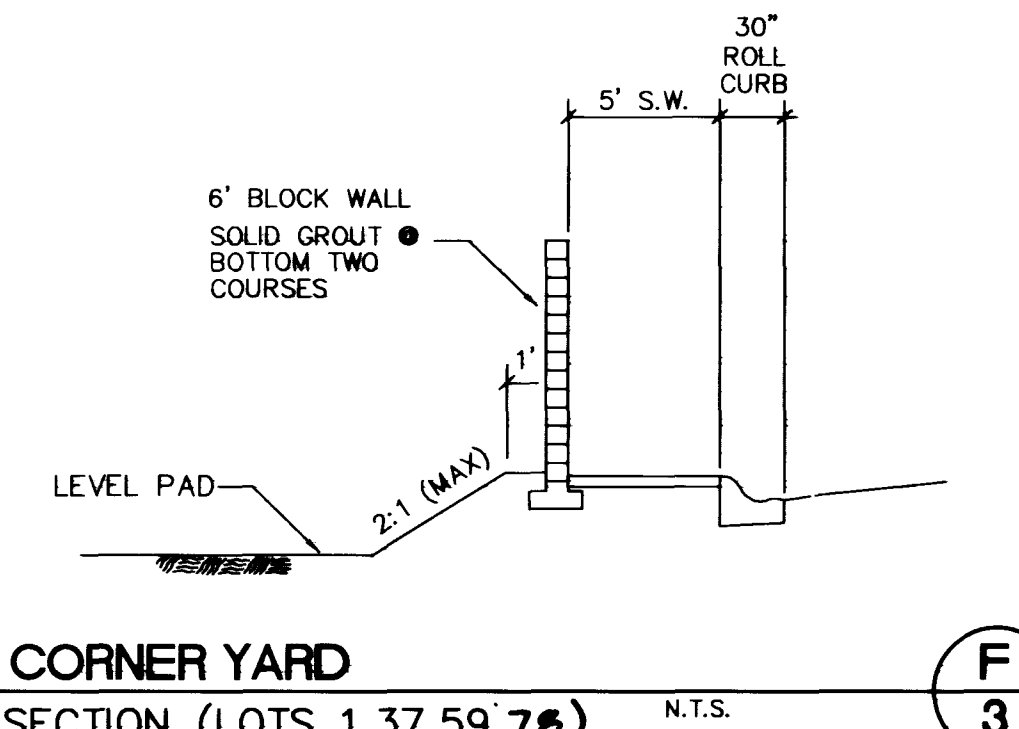

CORNER YARD
SECTION (LOTS 1,37,59,78) N.T.S. **F 3**

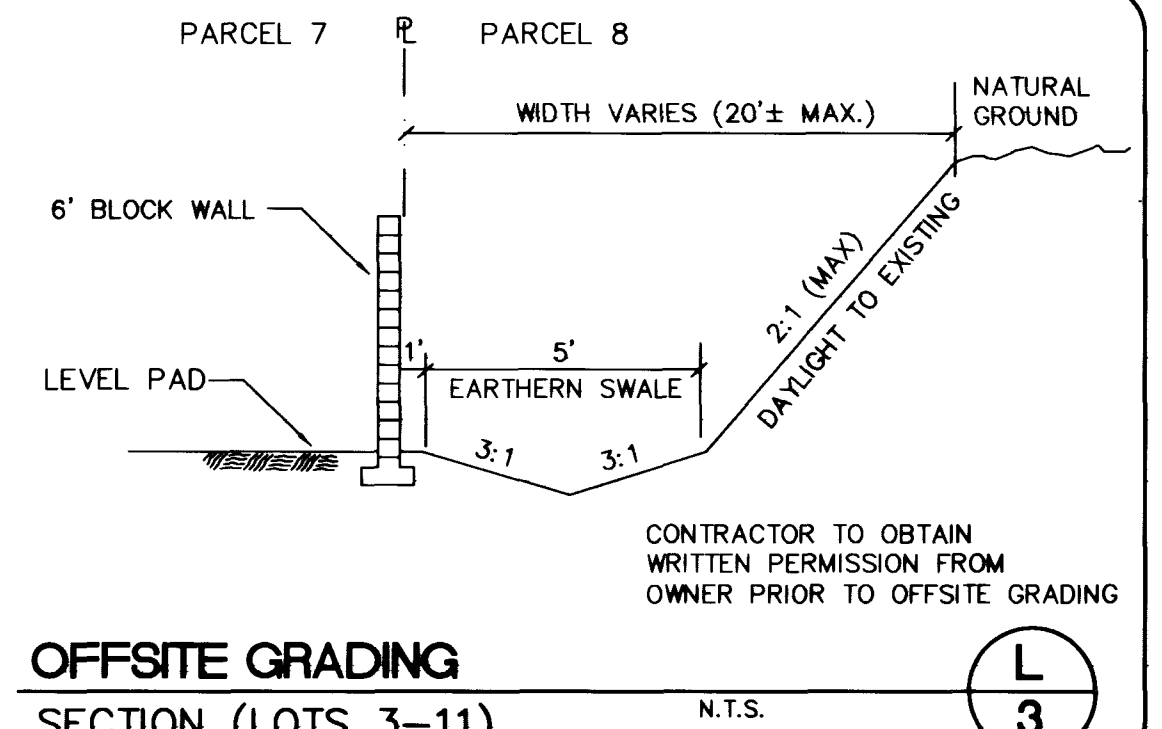

OFFSITE GRADING
SECTION (LOTS 3-11) N.T.S. **L 3**

WALL NOTES:

1. THE CONTRACTOR MUST VERIFY THE LOCATION, HEIGHT, AND TYPE OF ALL WALLS PRIOR TO CONSTRUCTION.
2. SEE SHEET 15 FOR WALL PLAN

Avoid cutting underground utility lines. It's costly.

Call before you Dig.

1-800-227-2600

UNDERGROUND SERVICE ALERT (USA)

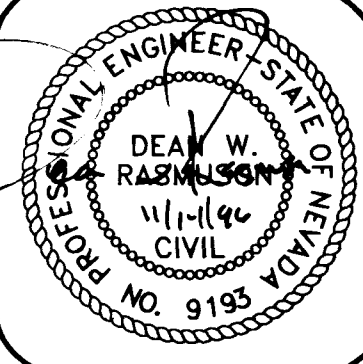

DESIGNED BY: P.J.M.	DATE: 11/09/96
DRAWN BY: P.J.M.	BY DATE
CHECKED BY: M.B.S.	REVISION
JOB NUMBER: 5184	
NO.	

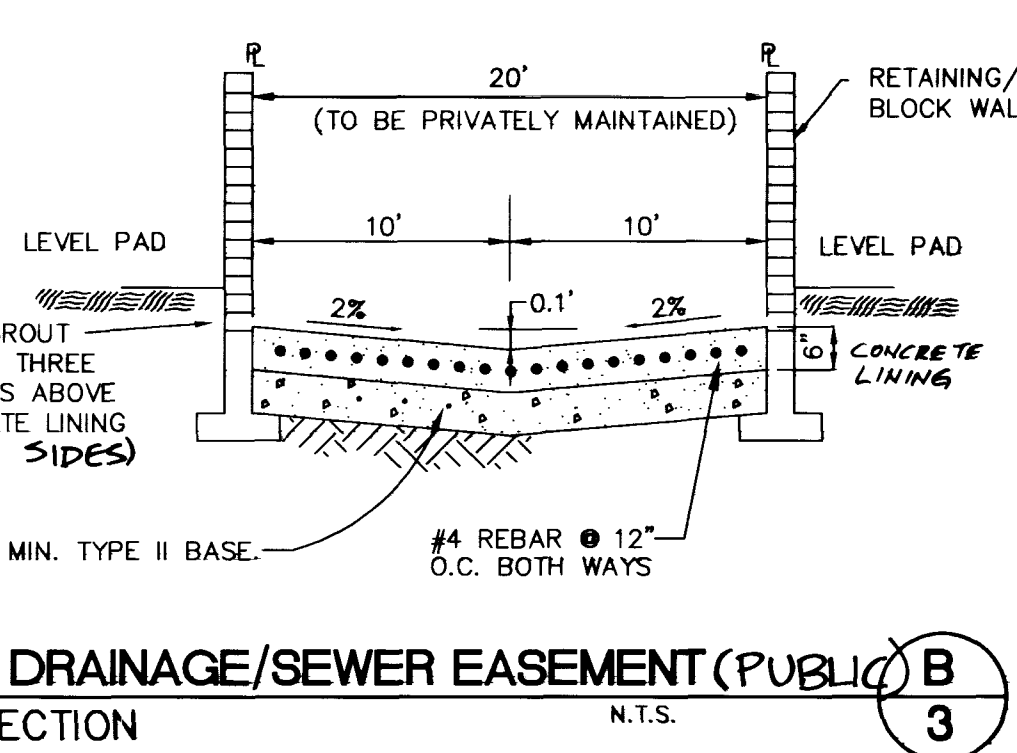
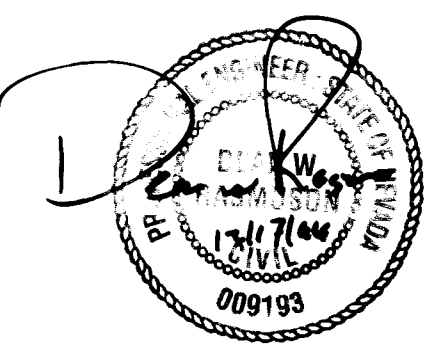

DRAINAGE/SEWER EASEMENT (PUBLIC)
SECTION N.T.S. **B 3**

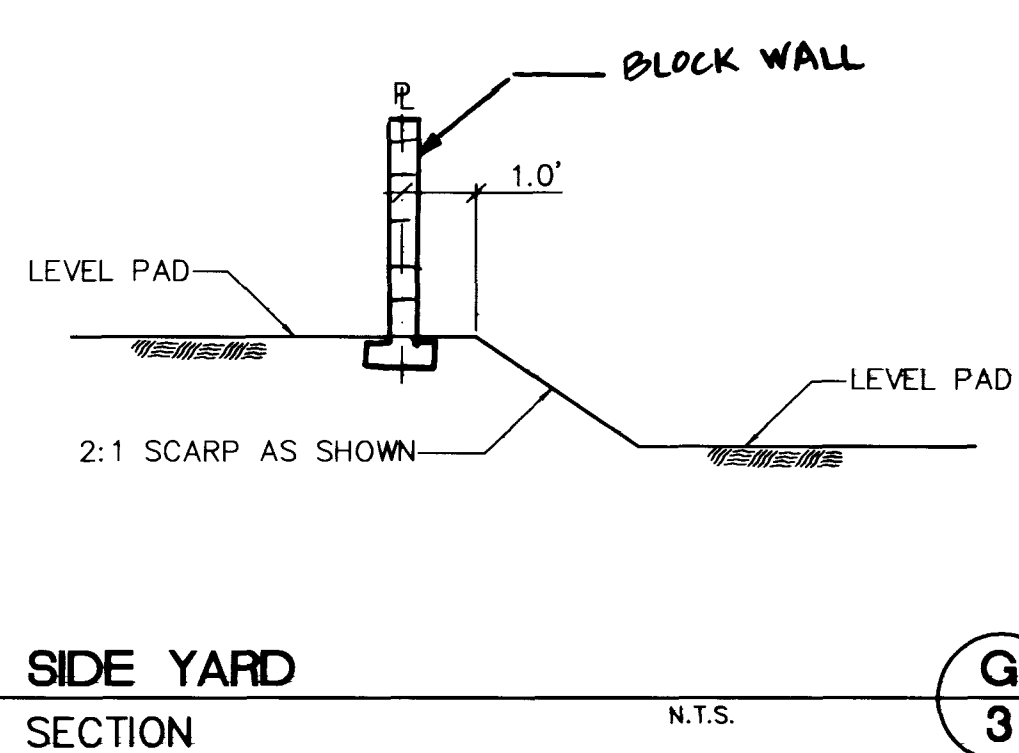

SIDE YARD
SECTION N.T.S. **G 3**

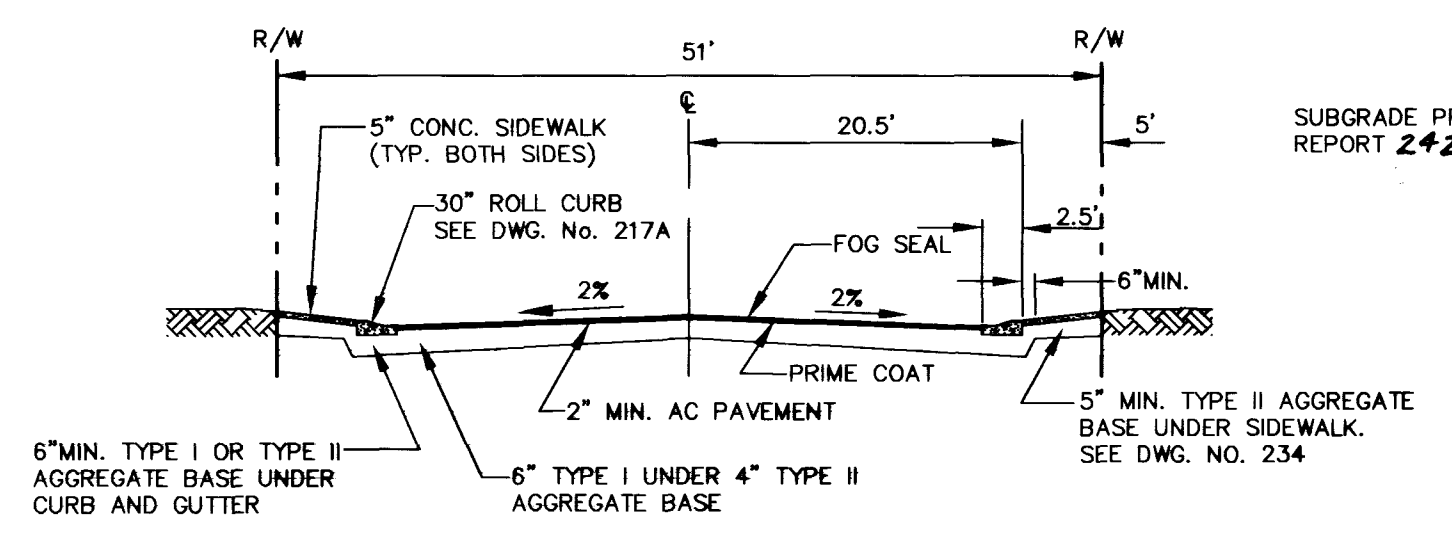

TYP. STREET CROSS-SECTION (5' R/W)
NO SCALE STD. DWG. No. 207

TUMBLING TRAIL RADIGAN AVENUE
SHADY GLEN AVENUE ROWDY STREET
TAILWIND AVENUE

NOTE: THE NORTH END OF TUMBLING TRAIL AND THE WEST END OF SHADY GLEN AVENUE ARE HALF-STREET IMPROVEMENTS WITH A.C. PAVEMENT 14.5' OVER CENTERLINE (AC OVERTAKE IS TEMPORARY)

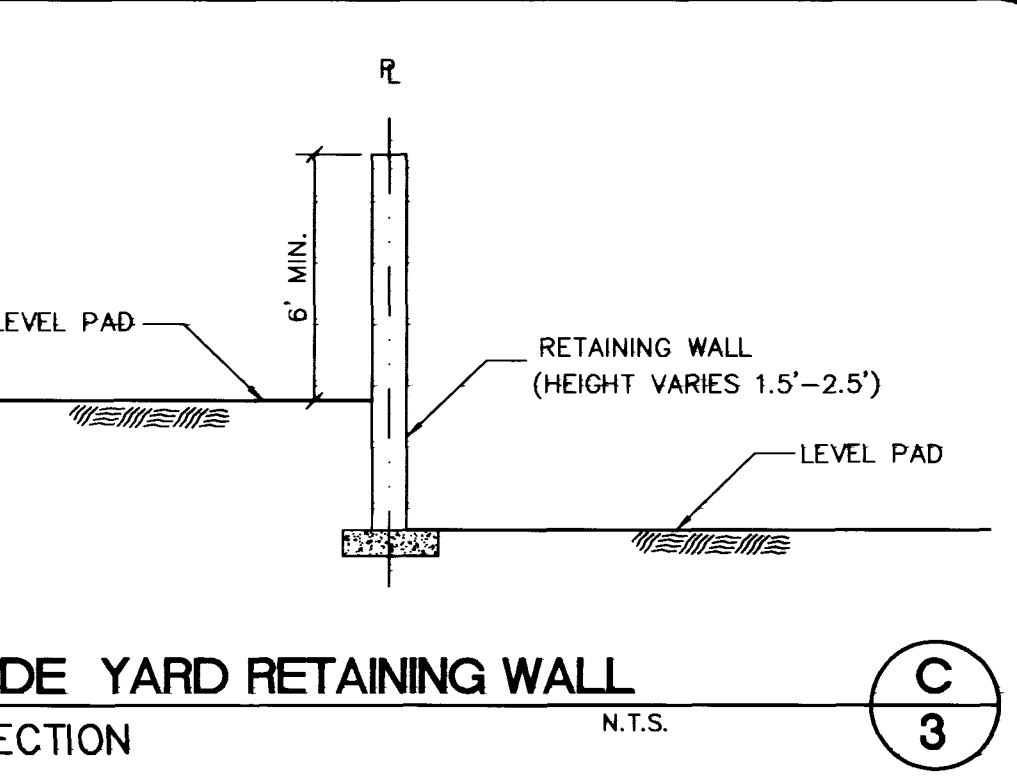

SIDE YARD RETAINING WALL
SECTION N.T.S. **C 3**

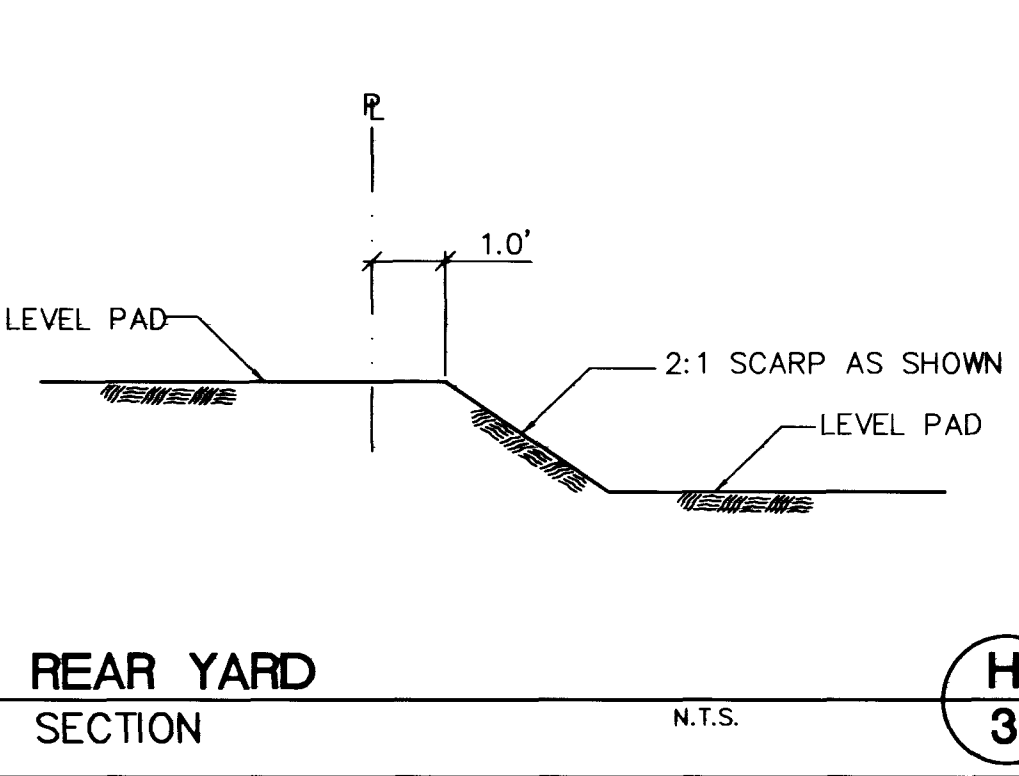

REAR YARD
SECTION N.T.S. **H 3**

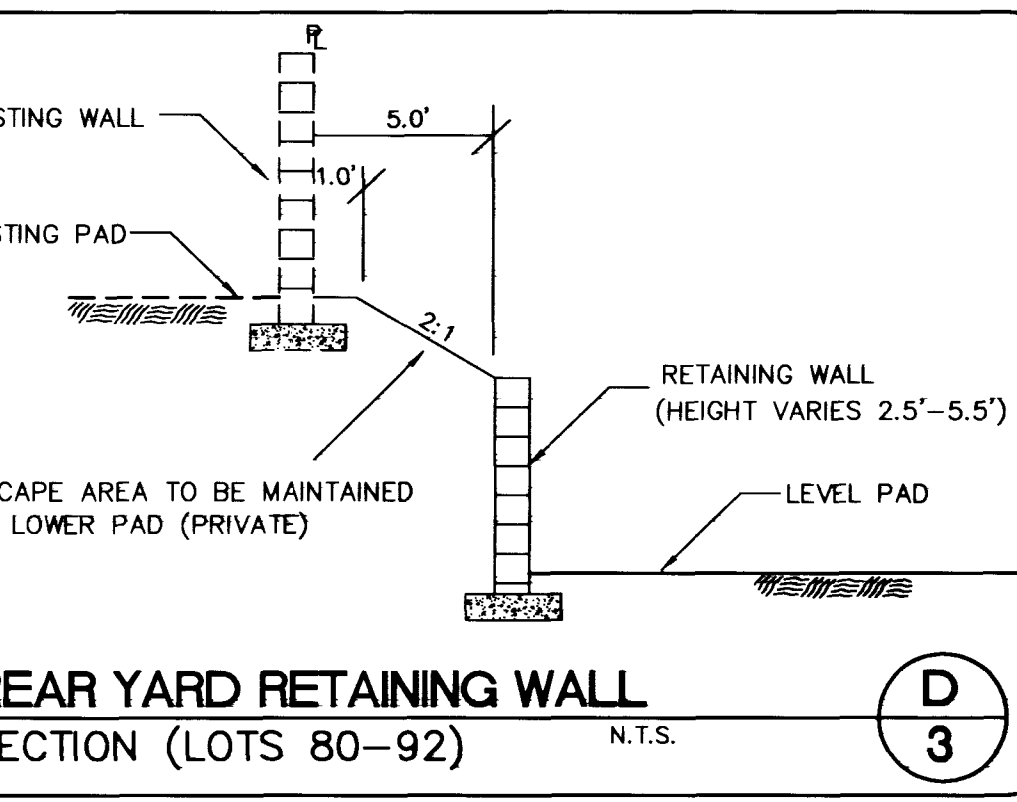

REAR YARD RETAINING WALL
SECTION (LOTS 80-92) N.T.S. **D 3**

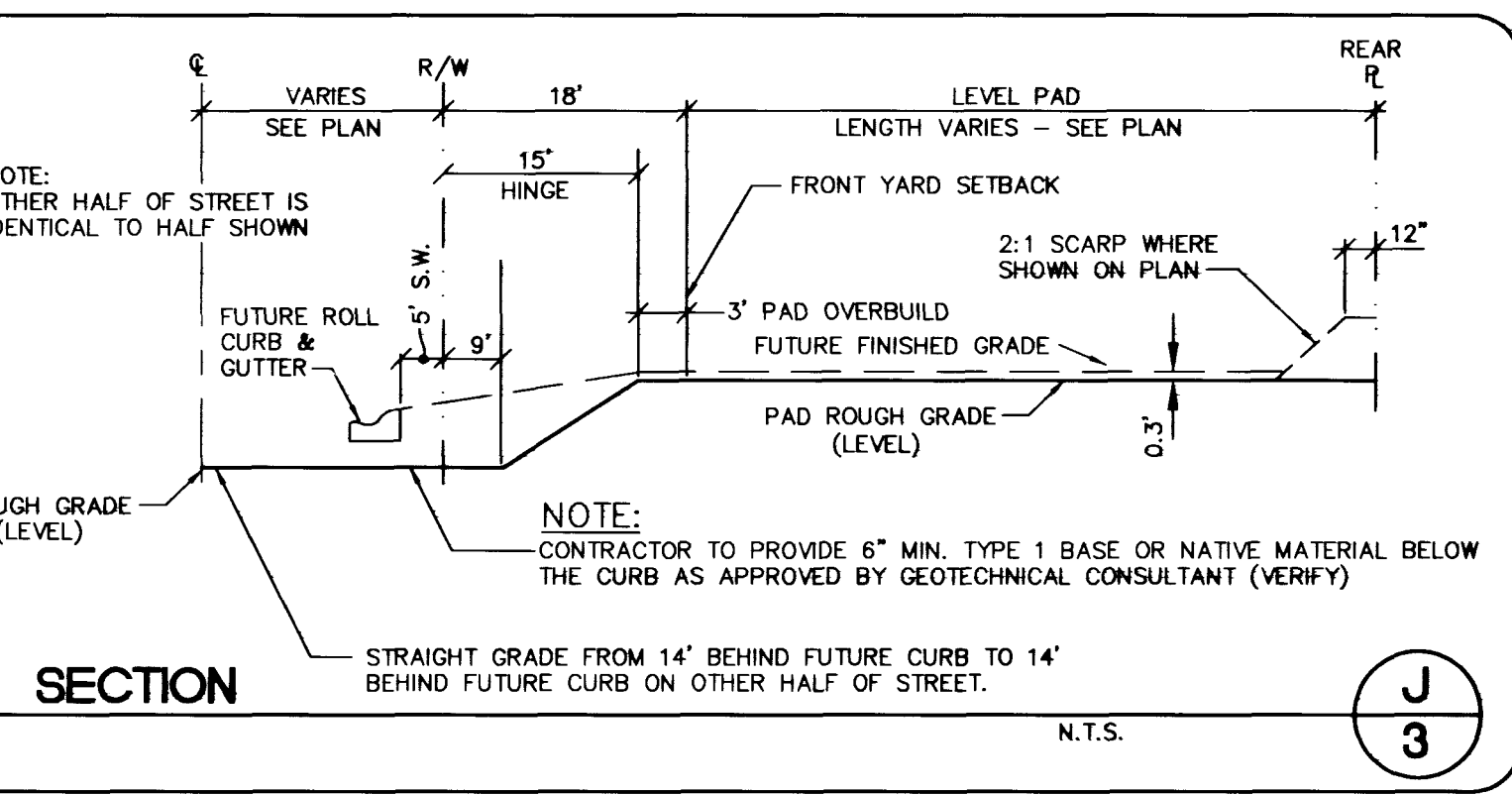

SECTION
N.T.S. **J 3**

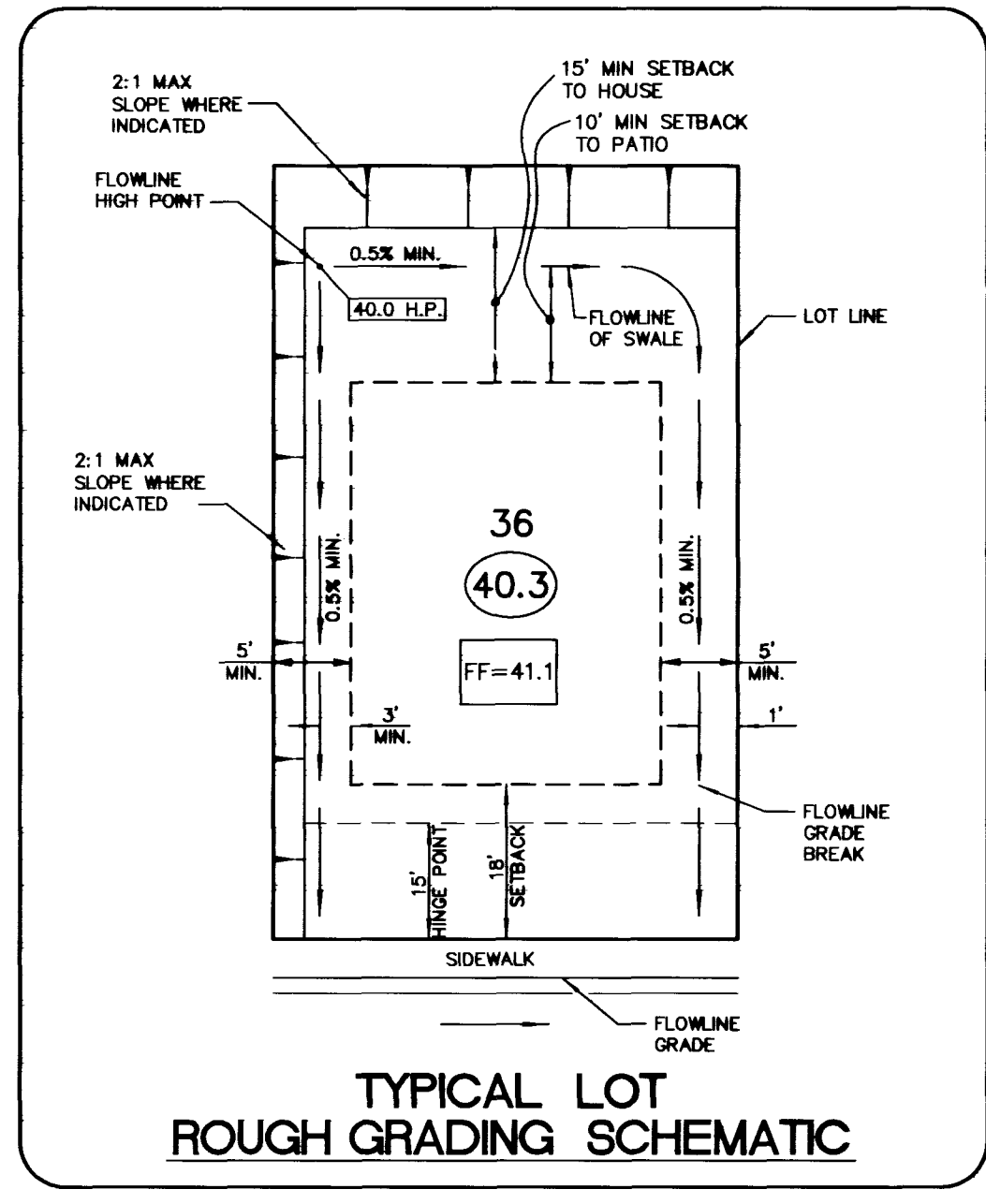

TYPICAL LOT ROUGH GRADING SCHEMATIC

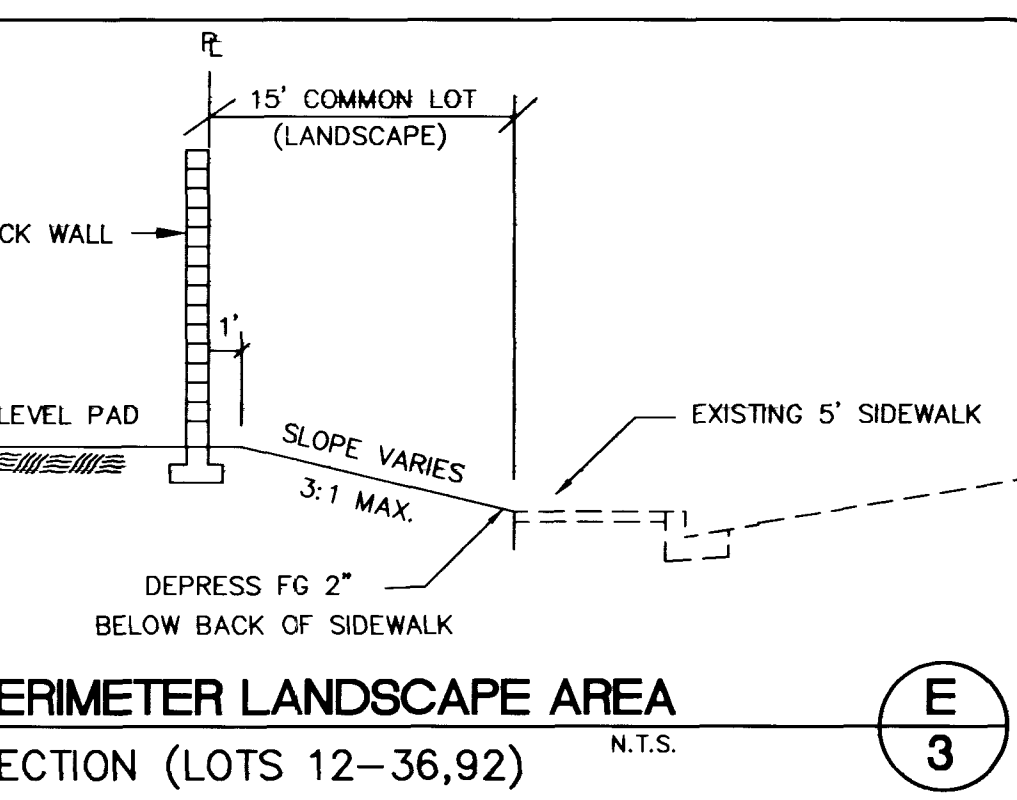

PERIMETER LANDSCAPE AREA
SECTION (LOTS 12-36,92) N.T.S. **E 3**

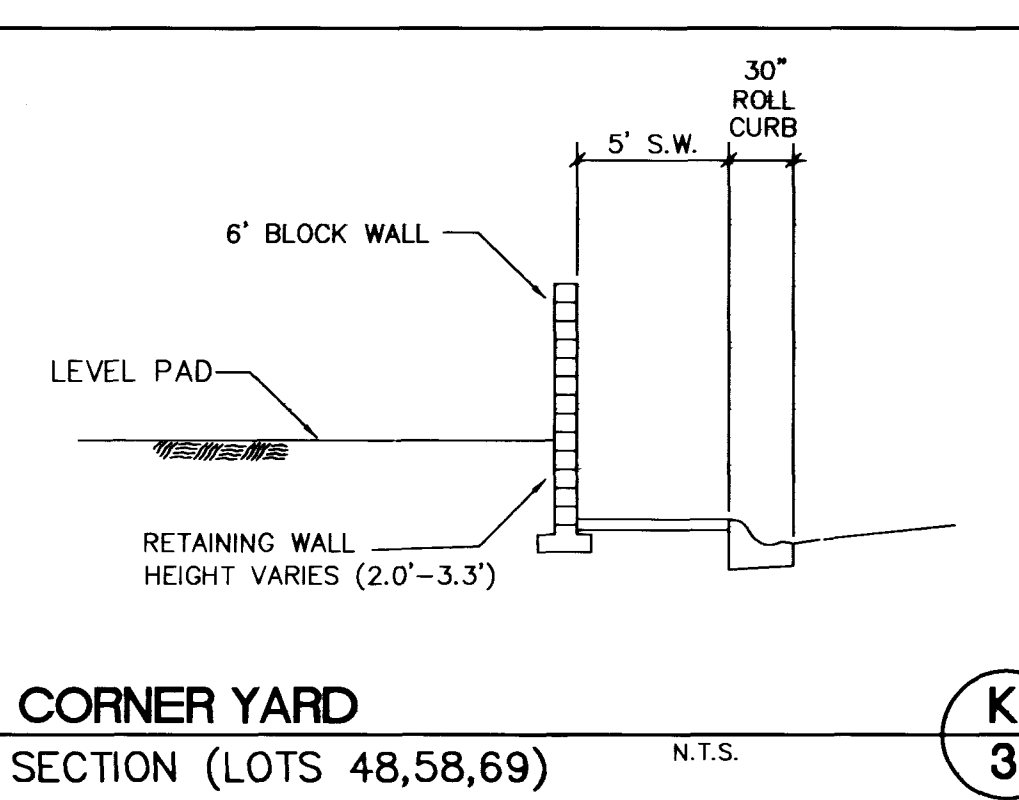

CORNER YARD
SECTION (LOTS 48,58,69) N.T.S. **K 3**

RICHMOND AMERICAN HOMES
ELKHORN SPRINGS-PARCEL 7
DETAILS

L. BRUCE NYBO, INC.
civil engineering • planning • land surveying
6700 South Paradise Road • Suite A-1
Las Vegas • Nevada • 89119
(702) 896-3262

SHEET 3

of 15

