

DESIGNED BY: DRJ	DRAWN BY: DRJ	DATE: 10/96
CHECKED BY: MS	JOB NUMBER: 001700X	BY DATE
NO.	REVISION	

WATT HOMES - NEVADA DIVISION
 ELKHORN SPRINGS - PARCEL 2
 UNIT 1 - BACKPACKER COURT &
 DUSTY LAKE STREET

NEVADA
 CITY OF LAS VEGAS

ORION ENGINEERING AND SURVEYING, INC.
 2700 CHANDLER AVENUE, SUITE B-1
 LAS VEGAS, NEVADA 89120
 (702) 739-5921, FAX (702) 739-5929

Orion

SHEET 8
 of 12

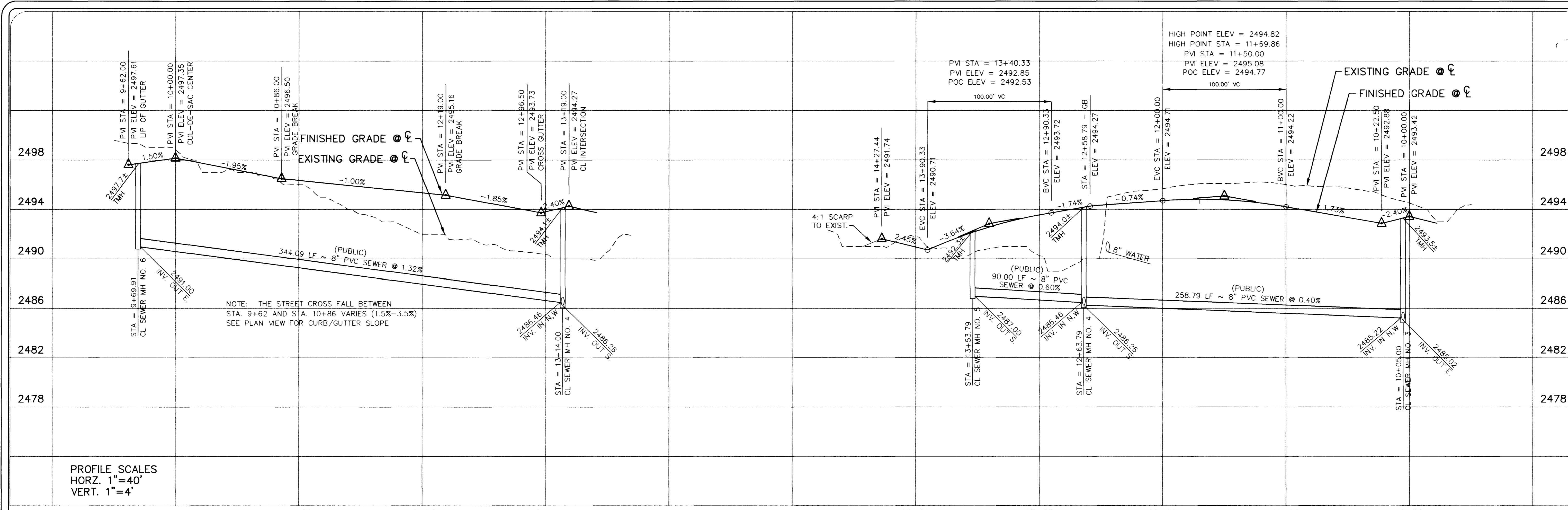

PROFILE SCALES
 HORZ. 1"=40'
 VERT. 1"=4'

BACK OF CURB - CURVE TABLE

CURVE	RADIUS	LENGTH	TANGENT	DELTA
C1	20.00'	31.42'	20.00'	90.0000°
C2	15.00'	41.21'	27.02'	94.7648°
C3	25.00'	37.33'	23.13'	85.3311°
C4	25.00'	20.07'	15.61'	46.0001°
C5	40.50'	96.13'	100.24'	136.0000°

CONSTRUCTION NOTES

- INSTALL 8" WIDE PCC CROSS GUTTER PER STD. DWG. NO. 228
- INSTALL CASE I SIDEWALK RAMP PER STD. DWG. NO. 235 A = 8', B = 8'
- INSTALL CASE I SIDEWALK RAMP PER STD. DWG. NO. 235 A = 15', B = 4.5'
- INSTALL CASE I SIDEWALK RAMP PER STD. DWG. NO. 235 A = 9', B = 4.5'
- CONSTRUCT 10' TRANSITION FROM 1" CURB TO ROLL CURB (CONTINUOUS FLOWLINE SLOPE)

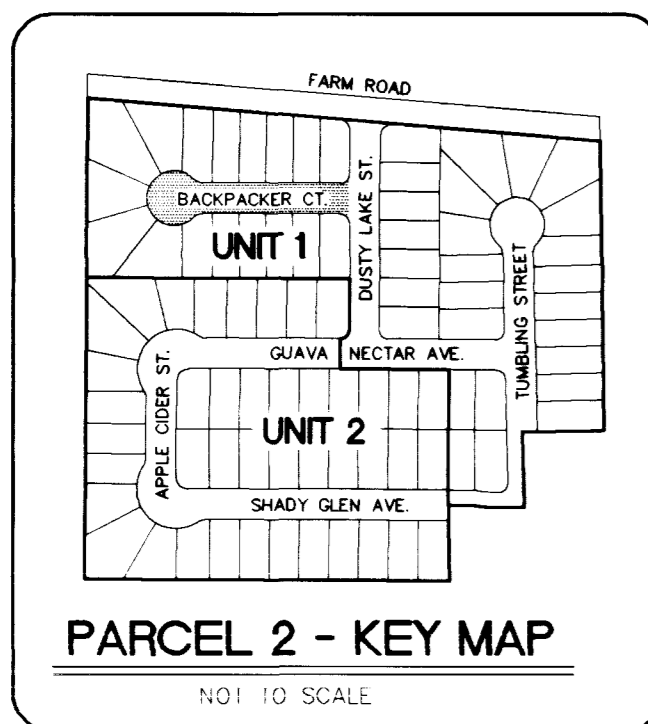
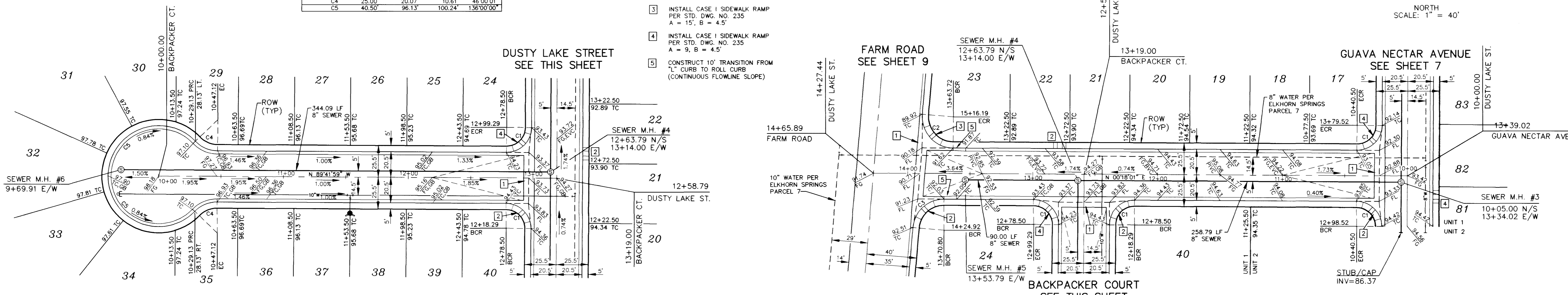

BACKPACKER COURT
 PUBLIC

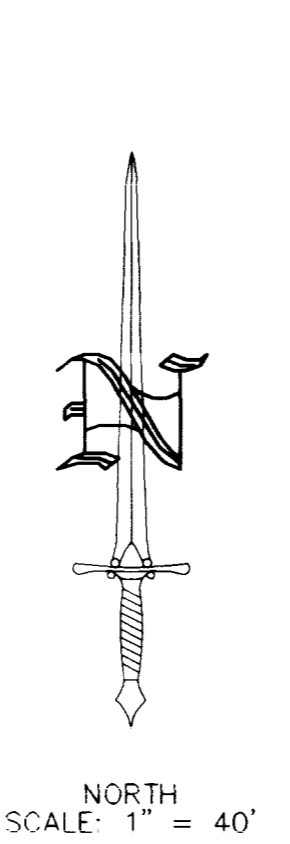

NORTH
 SCALE: 1" = 40'

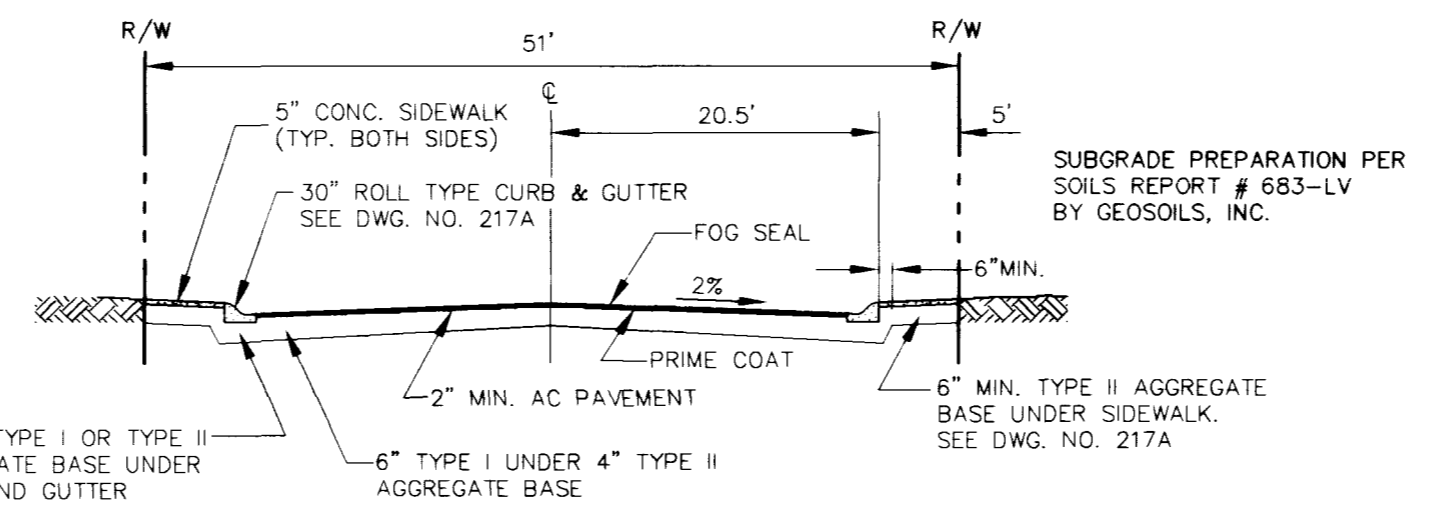

DUSTY LAKE STREET
 PUBLIC

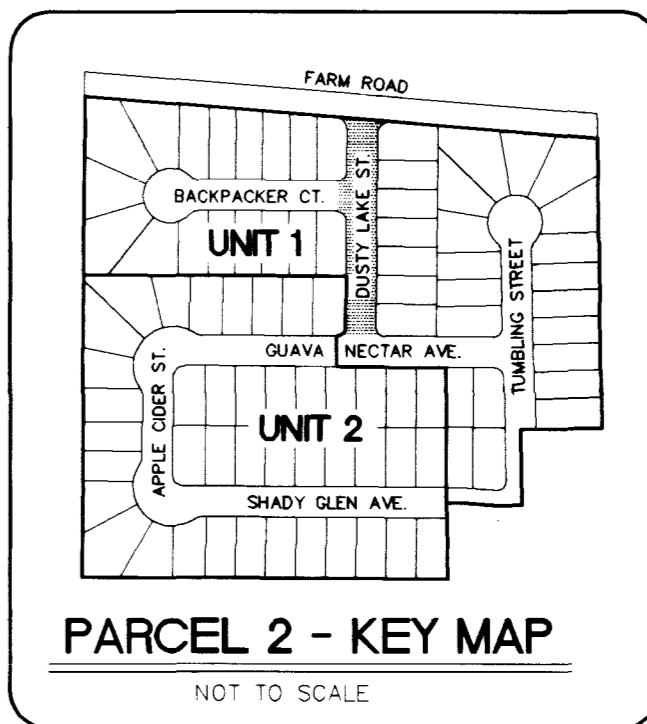

FILE NAME: 5185U107.DWG

4683

1074-4299-2-1



DATE	10/15/64
PROJECT	BACKPACKER COURT
CLIENT	ERL
SCALE	AS SHOWN
BY	W. J. ...
CHECKED BY	...
APPROVED BY	...

NOTICE: THESE PLANS WERE PREPARED BY THE ARCHITECT AND ENGINEER FOR THE PROJECT AND ARE NOT TO BE USED FOR ANY OTHER PROJECT WITHOUT THE WRITTEN CONSENT OF THE ARCHITECT AND ENGINEER.

ERL ARCHITECTS AND ENGINEERS, INC.
 10000 ERL DRIVE, ANN ARBOR, MICHIGAN 48106
 PHONE 764-1000

erion

NO. 10000
 10/15/64

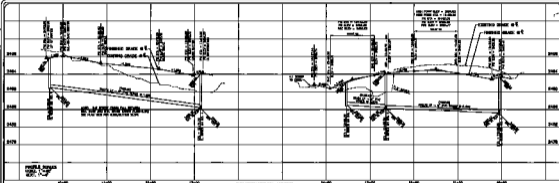

CONSTRUCTION NOTES

- 1. SEE ARCHITECT'S PLANS FOR FINISHES
- 2. SEE ARCHITECT'S PLANS FOR FINISHES
- 3. SEE ARCHITECT'S PLANS FOR FINISHES
- 4. SEE ARCHITECT'S PLANS FOR FINISHES
- 5. SEE ARCHITECT'S PLANS FOR FINISHES

NO.	DESCRIPTION
1	SEE ARCHITECT'S PLANS FOR FINISHES
2	SEE ARCHITECT'S PLANS FOR FINISHES
3	SEE ARCHITECT'S PLANS FOR FINISHES
4	SEE ARCHITECT'S PLANS FOR FINISHES
5	SEE ARCHITECT'S PLANS FOR FINISHES

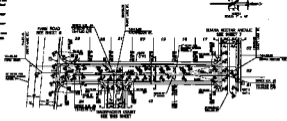

BACKPACKER COURT
 PUBLIC



DUSTY LAKE STREET
 PUBLIC

