

NOTE: All reinforcing 1/2" unless otherwise noted.

FED. ROAD DIV. NO.	STATE	FED. AID PROJ. NO.	FISCAL YEAR	COUNTY	CONTROL SECTION	SHEET NO.	TOTAL SHEETS
7	NEVADA	SSTATE	-	CLARK	CL 16	46	57

CHARLESTON DRAINAGE

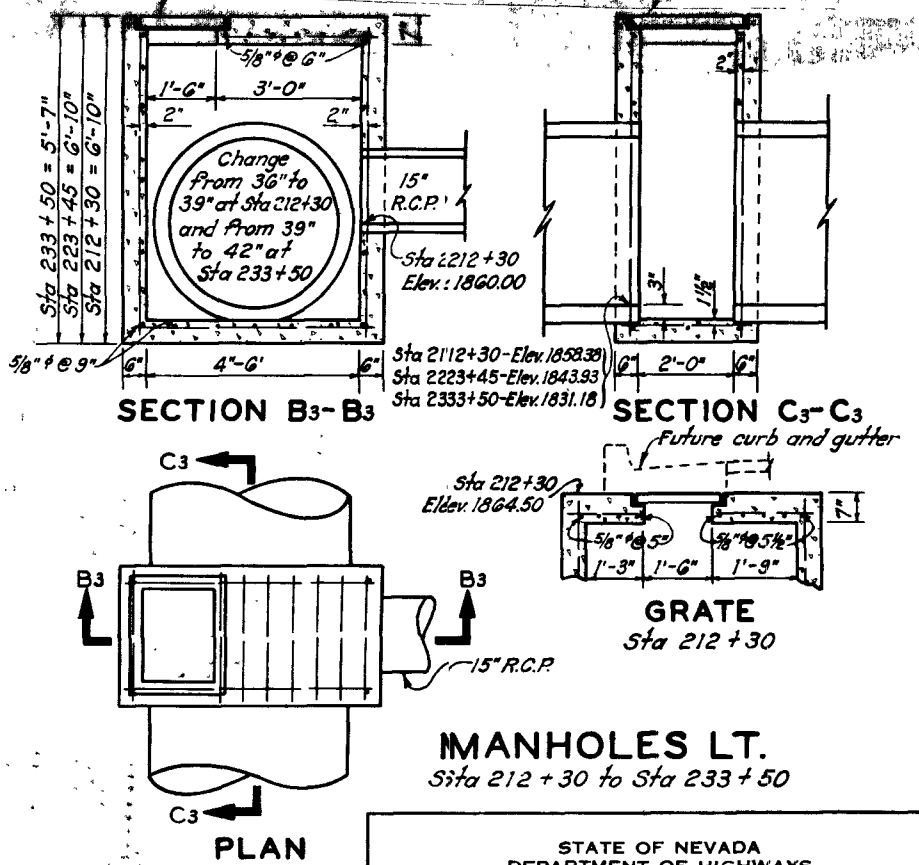
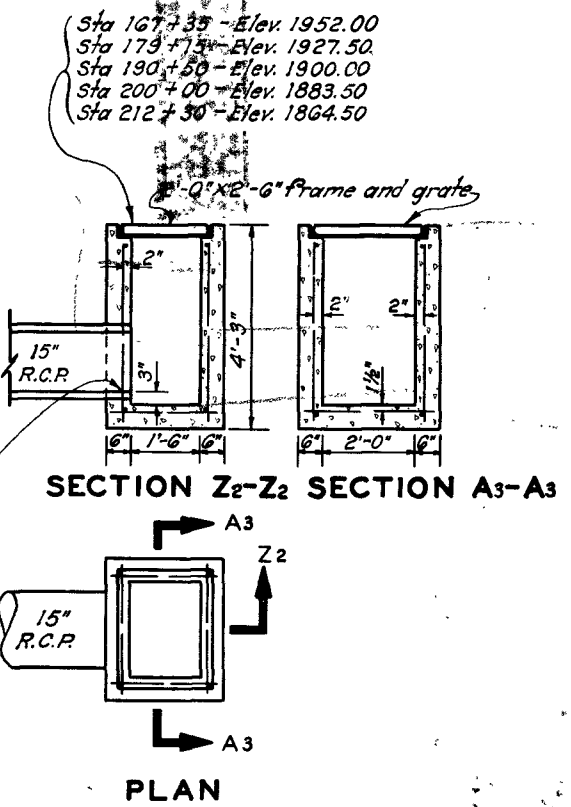
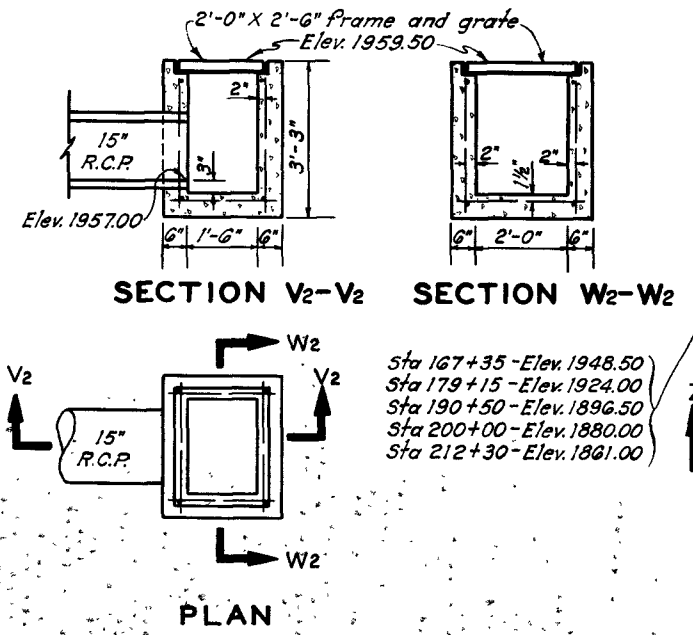
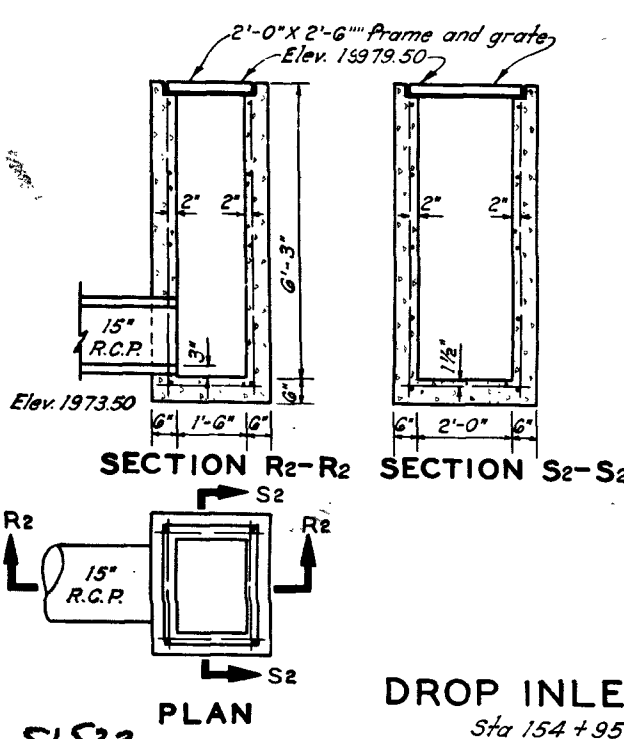
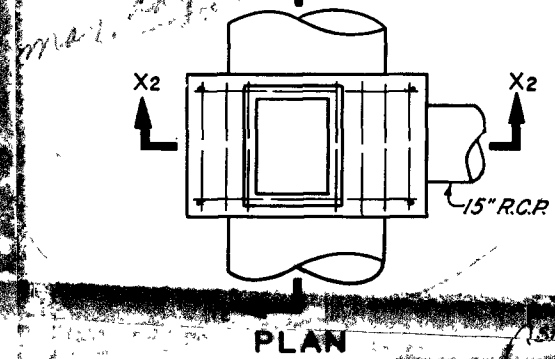
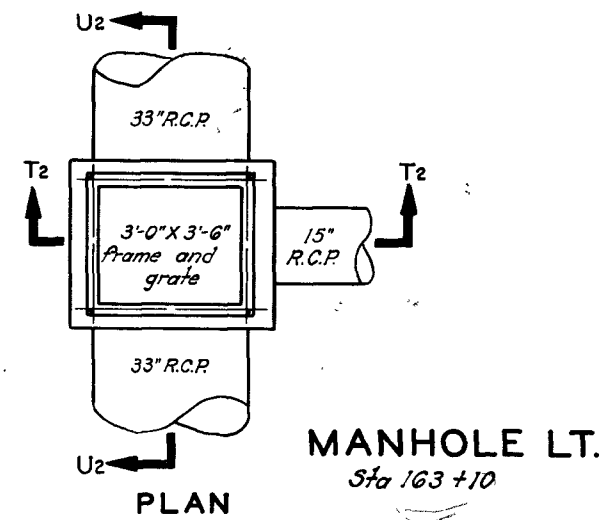
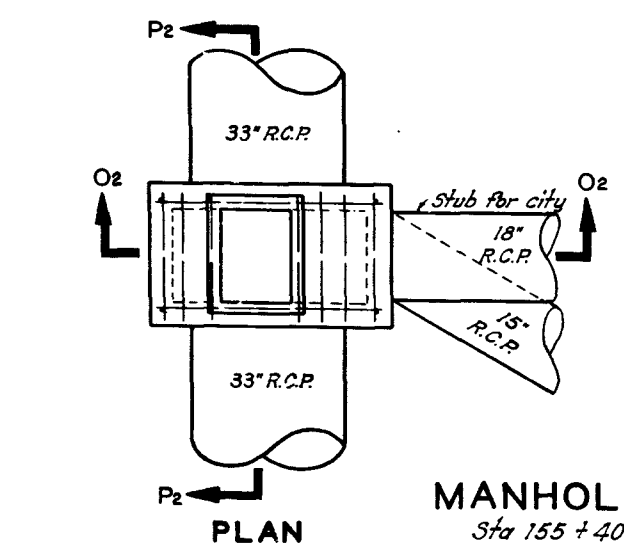
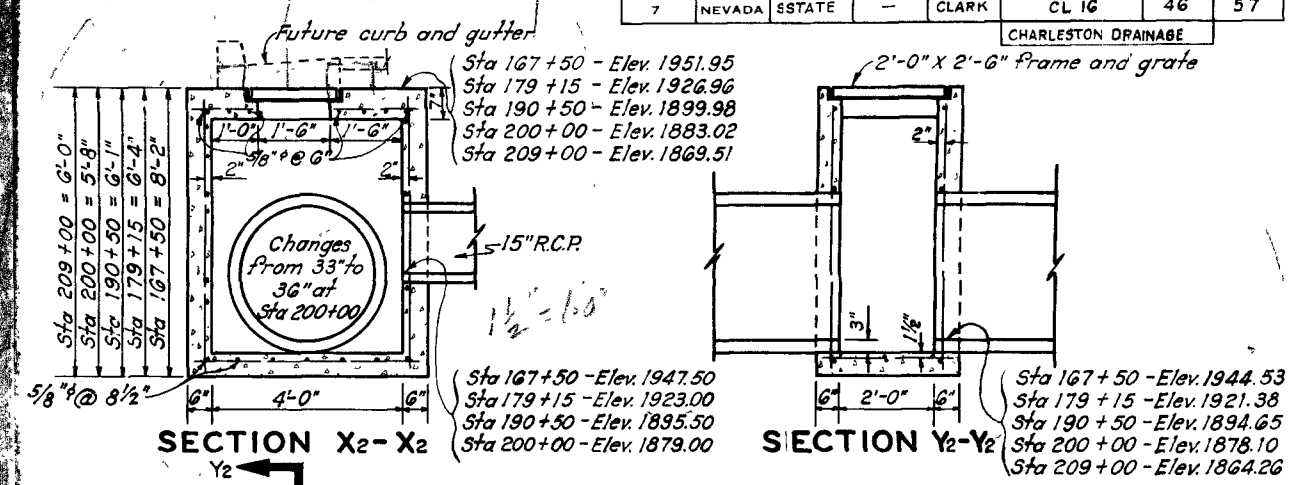
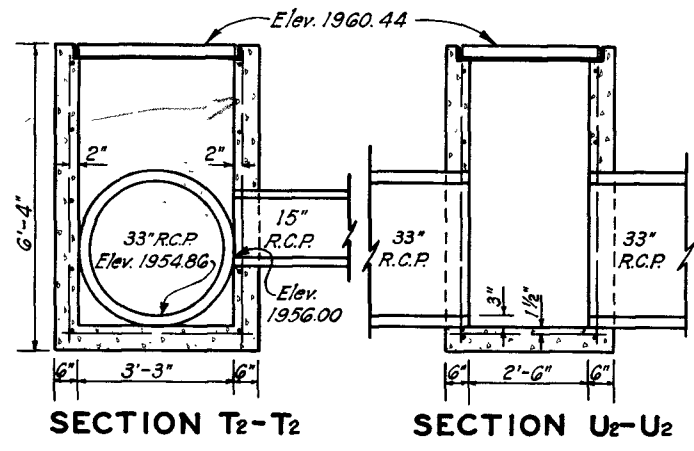
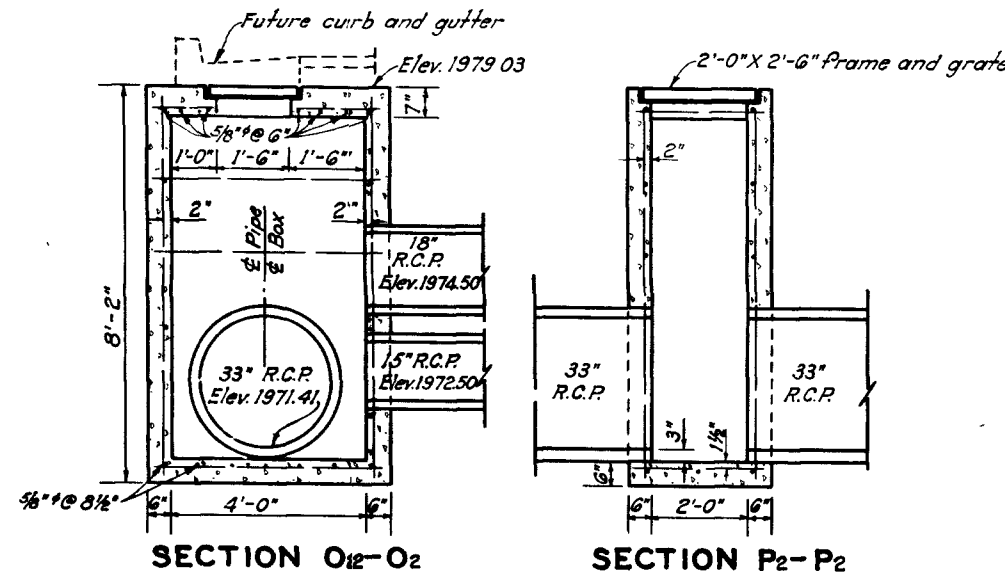

S1533

BRIDGE DEPARTMENT	DATE	CHECKED BY	DATE
BY			
DRAWING			
TRACING			

STATE OF NEVADA
DEPARTMENT OF HIGHWAYS

B-470
DRAINAGE DETAILS

DATE OF LAST REVISION: 102-V3689